

**ARKANSAS STATE HIGHWAY AND TRANSPORTATION DEPARTMENT
EQUIPMENT AND PROCUREMENT DIVISION
BID INVITATION**

Bid Number: M-15-020P

BID OPENING LOCATION:
AHTD Equipment and
Procurement Division
11302 W. Baseline Road
Little Rock, AR 72209

MAIL TO:
AHTD Equipment and
Procurement Division
P.O. Box 2261
Little Rock, AR 72203

DELIVER TO:
AHTD Equipment and
Procurement Division
11302 W. Baseline Road
Little Rock, AR 72209

Bid Opening Date: October 21, 2014 Time: 11:00 a.m.

Sealed bids for furnishing the commodities and/or services described below, subject to the Conditions on Page 2 of this Bid Invitation will be received at the above-noted mail and delivery locations until the above-noted bid opening date and time, and then publicly opened at the above-noted bid opening location. **Bids must be submitted on this form, with attachments when appropriate, or bids will be rejected. Late bids and unsigned bids will not be considered.**

In compliance with this Bid Invitation and subject to all the Conditions thereof, the undersigned offers and agrees to furnish any and all items upon which prices are quoted, at the price set opposite each item.

Company Name: _____

Name (Type or Print): _____

Address: _____

Title: _____

City: _____ State: _____ Zip: _____

Phone: _____ Fax: _____

Federal Tax ID or Social Security No.: _____

E-mail Address: _____

Signature: _____

Signature must be legible, original (not photocopied) and in ink.
Unsigned bids will be rejected.

Item No.	Description	Quantity	Unit	Unit Price	Amount
----------	-------------	----------	------	------------	--------

1.	Maintenance/Sign Shop Roof Renovation located at the Arkansas State Highway and Transportation Department Maintenance Annex Building, 11300 W. Baseline Rd., Little Rock, Arkansas 72209. (Job #42-84)				
	LUMP SUM _____				

To meet the requirements of Arkansas State Highway and Transportation Department Specifications attached to and made a part of this bid.

CONTACT PERSON: Phillip Watkins (501-569-2625)

Bid price shall include all labor, materials, and equipment necessary to perform the work as specified, and shall further include all licenses, fees, permits, royalties, and all taxes. Bid price shall represent full compensation for completion of the work. This provision supersedes Condition 4 on page 2 of Bid Invitation. Payment will be made in accordance with Arkansas Highway & Transportation Department Standard Specifications and Applicable Special Provisions.

Subsection 105.04, 108.07, 109.01 and 109.02 of the Arkansas State Highway and Transportation Department Standard Specifications for Highway Construction, Edition of 2014, will be in effect. (Specifications are accessible on our web site at www.arkansashighways.com.)

Bid Bond in the amount of 5% of total bid price required of all bidders at time of bid opening or bid will be rejected. **Personal and company checks are not acceptable as Bid Bonds.** See Condition 3 on page 2 of Bid Invitation.

Performance Bond only (no checks of any kind allowed) in the amount of 100% of total bid price will be required of successful bidder prior to providing goods/services. See Condition 3 on page 2 of Bid Invitation.

The successful bidder will be required to begin within 15 days after notice to begin and complete within 60 working days after notice to begin.

Arkansas Contractor's License No. _____
Current Arkansas Contractor's License Number must be listed or bid will be rejected
(A.C.A. ¶17-25-101 *et seq.*).

Bids and Specifications are available on-line by going to the AHTD Web Site – www.arkansashighways.com and clicking on "Commodities and Services Bids/Contracts Information". Tabulations will also be available at this site within 72 hours after bid opening. If you have any questions, call this office at 501-569-2667.

STANDARD BID CONDITIONS

M-15-020P

1. **ACCEPTANCE AND REJECTION:** The Arkansas State Highway and Transportation Department (AHTD) reserves the right to reject any or all bids, to accept bids in whole or in part (unless otherwise indicated by bidder), to waive any informalities in bids received, to accept bids on materials or equipment with variations from specifications where efficiency of operation will not be impaired, and to award bids to best serve the interest of the State.
2. **PRICES:** Unless otherwise stated in the Bid Invitation, the following will apply: (1) unit prices shall be bid, (2) prices should be stated in units of quantity specified (feet, each, lbs., etc.), (3) prices must be F.O.B. destination specified in bid, (4) prices must be firm and not subject to escalation, (5) bid must be firm for acceptance for 30 days from bid opening date. In case of errors in extension, unit prices shall govern. Discounts from bid price will not be considered in making awards.
3. **BID BONDS AND PERFORMANCE BONDS:** If required, a **Bid Bond** in the form of a cashier's check, certified check, or surety bond issued by a surety company, in an amount stated in the Bid Invitation, must accompany bid. **Personal and company checks are not acceptable as Bid Bonds.** Failure to submit a Bid Bond as required will cause a bid to be rejected. The Bid Bond will be forfeited as liquidated damages if the successful bidder fails to provide a required Performance Bond within the period stipulated by AHTD or fails to honor their bid. When a bidder claims and can show clear and convincing evidence that a material mistake was made in the bid and was not the bid intended, the bidder may be permitted to withdraw their bid prior to award without forfeiture of bid bond. Cashier's checks and certified checks submitted as Bid Bonds will be returned to unsuccessful bidders; surety bonds will be retained. The successful bidder will be required to furnish a **Performance Bond** in an amount stated in the Bid Invitation and in the form of a cashier's check, certified check, or surety bond issued by a surety company, unless otherwise stated in the Bid Invitation, as a guarantee of delivery of goods/services in accordance with the specifications and within the time established in the bid. **Personal and company checks are not acceptable as Performance Bonds.** In some cases, a cashier's check or certified check submitted as a Bid Bond will be held as the Performance Bond of the successful bidder. Cashier's checks or certified checks submitted as Performance Bonds will be refunded shortly after payment has been made to the successful bidder for completion of all terms of the bid; surety bonds will be retained. Surety bonds must be issued by a surety company authorized to do business in Arkansas, and must be signed by a Resident Local Agent licensed by the Arkansas State Insurance Commissioner to represent that surety company. Resident Agent's Power-of-Attorney must accompany the surety bond. Certain bids involving labor will require Performance Bonds in the form of surety bonds only (no checks of any kind allowed). These bonds shall not only serve to guarantee the completion of the work, but also to guarantee the excellence of both workmanship and material until the work is finally accepted and the provisions of the Plans, Specifications, and Special Provisions fulfilled. In such cases, the company issuing the surety bond must comply with all stipulations herein and must be named in the U. S. Treasury listing of companies holding Certificates of Authority as acceptable sureties on Federal Bonds and as acceptable reinsuring companies. Any excess between the face amount of the bond and the underwriting limitation of the bonding company shall be protected by reinsurance provided by an acceptable reinsuring company. Annual Bid and Performance Bonds on file with E & P Division must have sufficient unencumbered funds to meet current bonding requirements, or the bid will be rejected, unless the balance is submitted as set forth above, prior to bid opening.
4. **TAXES:** The AHTD is not exempt from Arkansas State Sales and Use Taxes, or local option city/county sales taxes, when applicable, and bidders are responsible to the State Revenue Department for such taxes. These taxes should not be included in bid prices, but where required by law, will be paid by the AHTD as an addition thereto, and should be added to the billing to the AHTD. The AHTD is exempt from Federal Excise Taxes on all commodities except motor fuels; and excise taxes should not be included in bid prices except for motor fuels. Where applicable, tax exemption certificates will be furnished by the AHTD.
5. **"ALL OR NONE" BIDS:** Bidders who wish to bid "All or None" on two or more items shall so stipulate on the face of bid sheet; otherwise, bid may be awarded on an individual item basis.
6. **SPECIFICATIONS:** Complete specifications should be attached for any substitution or alternate offered, or where amplification is necessary. Bidder's name must be placed on all attachments to the bid.
7. **EXCEPTIONS TO SPECIFICATIONS:** Any exceptions to the bid specifications must be stated in the bid. Any exceptions to manufacturer's published literature must be stated in the bid, or it will be assumed that bidder is bidding exactly as stated in the literature.
8. **BRAND NAME REFERENCES:** All brand name references in bid specifications refer to that commodity or its equivalent, unless otherwise stated in Bid Invitation. Bidder should state brand or trade name of item being bid, if such name exists.
9. **FREIGHT:** All freight charges should be included in bid price. Any change in common carrier rates authorized by the Interstate Commerce Commission will be adjusted if such change occurs after the bid opening date. Receipted common carrier bills that reflect ICC authorized rate changes must be furnished.
10. **SAMPLES, LITERATURE, DEMONSTRATIONS:** Samples and technical literature must be provided free of any charge within 14 days of AHTD request, and free demonstrations within 30 days, unless AHTD extends time. Failure to provide as requested within this period may cause bid to be rejected. Samples, literature and demonstrations must be substantially the same as the item(s) being bid, unless otherwise agreed to by AHTD. Samples that are not destroyed will be returned upon request at bidders expense. Samples from successful bidders may be retained for comparison with items actually furnished.
11. **GUARANTY:** Unless otherwise indicated in Bid Invitation, it is understood and agreed that any item offered or shipped on this bid shall be newly manufactured, latest model and design, and in first class condition; and that all containers shall be new, suitable for storage or shipment and in compliance with all applicable laws relating to construction, packaging, labeling and registration.
12. **BACKORDERS OR DELAY IN DELIVERY:** Backorders or failure to deliver within the time required may constitute default. Vendor must give written notice to the AHTD, as soon as possible, of the reason for any delay and the expected delivery date. The AHTD has the right to extend delivery if reasons appear valid. If reason or delivery date is not acceptable, vendor is in default.
13. **DEFAULT:** All commodities furnished will be subject to inspection and acceptance by AHTD after delivery. Default in promised delivery or failure to meet specifications authorizes the AHTD to cancel award or any portion of same, to reasonably purchase commodities or services elsewhere and to charge full increase, if any, in cost and handling to defaulting vendor. Applicable bonds may be forfeited.
14. **ETHICS:** *"It shall be a breach of ethical standards for a person to be retained, or to retain a person, to solicit or secure a State contract upon an agreement of understanding for a commission, percentage, brokerage, or contingent fee, except for retention of bona fide employees or bona fide established commercial selling agencies maintained by the contractor for the purpose of securing business."* (Arkansas Code, Annotated, Section 19-11-708).

ARKANSAS STATE HIGHWAY AND TRANSPORTATION DEPARTMENT

NOTICE OF NONDISCRIMINATION

The Arkansas State Highway and Transportation (Department) complies with the Americans with Disabilities Act of 1990, Section 504 of the Rehabilitation Act of 1973, Title VI of the Civil Rights Act of 1964 and other federal equal opportunity laws and therefore does not discriminate on the basis of race, sex, color, age, national origin, religion or disability, in admission or access to and treatment in Department programs and activities, as well as the Department's hiring or employment practices. Complaints of alleged discrimination and inquiries regarding the Department's nondiscrimination policies may be directed to Joanna P. McFadden, Section Head - EEO/DBE (ADA/504/Title VI Coordinator), P. O. Box 2261, Little Rock, AR 72203, (501) 569-2298, (Voice/TTY 711), or the following email address:

Joanna.Mcfadden@arkansashighways.com.

This notice is available from the ADA/504/Title VI Coordinator in large print, on audiotape and in Braille.

ARKANSAS STATE HIGHWAY AND TRANSPORTATION DEPARTMENT

SPECIAL PROVISION

LIQUIDATED DAMAGES

As specified in the Contract, liquidated damages for this project will be as shown in the following table:

WORKING DAY PROJECTS

ORIGINAL CONTRACT AMOUNT		RATE
FROM MORE THAN	TO AND INCLUDING	-----
\$ 0	\$ 50,000	\$ 400
50,000	100,000	700
100,000	500,000	800
500,000	1,000,000	1,100
1,000,000	2,000,000	1,300
2,000,000	5,000,000	1,500
5,000,000	10,000,000	1,900
10,000,000	15,000,000	2,000
15,000,000	20,000,000	2,100
20,000,000	-----	2,500

FIXED DATE PROJECTS

ORIGINAL CONTRACT AMOUNT		RATE
FROM MORE THAN	TO AND INCLUDING	-----
\$ 0	\$ 50,000	\$ 90
50,000	100,000	100
100,000	500,000	200
500,000	1,000,000	250
1,000,000	2,000,000	320
2,000,000	5,000,000	400
5,000,000	10,000,000	600
10,000,000	-----	750

**ARKANSAS STATE HIGHWAY AND TRANSPORTATION DEPARTMENT
SPECIFICATIONS
JOB 42-84
MAINTENANCE/SIGN SHOP ROOF RENOVATION
LITTLE ROCK, ARKANSAS**

SCOPE

Work under this item shall consist of a new Roof, for the Maintenance Annex Building located at 11300 West Baseline, Little Rock, AR 72209. All work for the complete Roof Installation shall be as indicated on the Plans, as called for in these Specifications, or as directed by the Engineer. These Specifications and the Plans cover the furnishing of all materials, labor, tools, equipment, machinery, caulking, drayage, rigging, fees, permits, and any and all incidental items required to complete the work.

LOCAL CONDITIONS

Bidders are required to visit the site prior to submission of proposal to familiarize themselves with local conditions, including general characteristics of the existing structures and contents and accessibility of the work.

PERMITS

The Contractor, if awarded the Contract for the new Roof Installation, shall obtain and also pay for all permits required, shall give all legal notices, and shall pay for all fees and taxes required for the work.

EXAMINATION OF PLANS AND SPECIFICATIONS

The Contractor shall examine the Plans and Specifications and shall become fully informed as to the extent and character of the work to be performed. No consideration will be given to alleged misunderstanding of materials to be furnished or work to be required under this Contract. Submission of a bid is an implied consent to the conditions of these Specifications and of the Plans.

PROTECTION OF EXISTING FACILITY

The Contractor is advised that the work is to be performed in and on an existing building, which is occupied. The Contractor shall exercise care and caution to prevent interference with those working in these facilities. The Contractor is also advised that he is responsible for protecting the existing facilities and occupants against damage or injury from his workmen, work in progress, or the elements.

SCHEDULING AND COMPLETION OF WORK

The Contractor shall schedule his work so as to create a minimum amount of inconvenience to the normal work routine of the District or Maintenance Personnel.

ACCESS TO THE WORK

The Engineer or his representatives shall have access to the work at all times and shall be permitted to approach, enter or examine all stages or phases of the work as it progresses, and shall have authority to reject work which is defective in workmanship or material.

REQUIRED SUPERVISION

The Contractor shall keep on the job at all times, when work is in progress, a competent superintendent satisfactory to the Engineer. The superintendent shall represent the Contractor in his absence and all instructions given to him shall be binding on the Contractor. Workmanship shall be by craftsmen skilled in their trade and shall be in accordance with the best standard practice.

ACCIDENT PREVENTION

Precaution shall be exercised at all times for the protection of persons and property. The safety provisions of applicable laws, building and construction codes shall be observed. Machinery, equipment and other hazards shall be guarded in accordance with safety provisions of the Manual of Accident Prevention in Construction, published by the Associated General Contractors of America, to the extent that such provisions are not in contravention of applicable laws. The Contractor shall be responsible for any damage which may be caused by workmen during the performance of the work.

CONTRACT TIME LIMIT

The Contractor shall begin within Fifteen (15) days after notice to begin and shall complete the work within Sixty (60) working days after notice to begin.

QUALITY OF MATERIAL

All material, appliances or appurtenances furnished under these Specifications shall be new, unused, and shall be free from defects and imperfections. Any material, appliance or appurtenance found to be defective shall be replaced by the Contractor at no additional cost to the Arkansas State Highway and Transportation Department, for material or labor. All material shall comply with the Arkansas State Highway and Transportation Department Standard Specifications for Highway Construction, Edition of 2014 and these Specifications. Any material not covered in the above Specifications or on the Plans shall be approved by the Engineer.

SUBMITTALS

A. Product Data:

1. Provide membrane manufacturer's printed data sufficient to show that all components of roofing system, including insulation and fasteners, comply with the specified requirements and with the membrane manufacturer's requirements and recommendations for the system type specified; include data for each product used in conjunction with roofing membrane.
2. Installation Instructions: Provide manufacturer's instructions to installer, marked up to show exactly how all components will be installed; where instructions allow installation options, clearly indicate which option will be used.
3. Installer Qualifications: Letter from manufacturer attesting that the roofing installer meets the specified qualifications.

SUBSTITUTION OF MATERIAL

It is intended that the Contractor have the option of substituting a material or appliance that will perform the function equally as well as the one named. The Engineer shall be given written notice one (1) week prior to the proposed use of a substitution so that a decision can be made as to the equal merits of the two (2) products. No substituted items shall be installed until written approval is received by the Contractor.

CLEAN-UP

The Contractor shall not allow any waste material or rubbish caused by his employees to accumulate in or about the premises but shall promptly remove same. At completion of the work, all rubbish, tools, scaffolding and surplus materials shall be removed and the Contractor shall leave the site clean and ready to use.

WARRANTY

The later detailed minimum "Single-Ply 45 Mil TPO Membrane Roof System", shall be applied by Roofing Contractor who is approved by the Roofing Manufacturer. The Roofing Manufacturer's Representative shall make any inspections he deems necessary to warranty the roof system against defective materials and/or workmanship for a period of not less than twenty (20) years with a "No Dollar Limit" on the guarantee. This shall be on the Manufacturer's Guarantee Form/Document properly executed by the Manufacturer, and is a requirement for final payment.

GENERAL

This work shall consist of the installation of flute fill insulation between standing seams with EPS (expanded polystyrene) insulation and preliminarily fasten the EPS to existing roof panels. A Firestone 1-1/2" IsoGard HD board or equivalent will then be laid over the roofing system and fastened with Heavy Duty Fasteners. A Firestone **TAN** 45 mil TPO or equivalent will be fully adhered to the cover board as noted on the Plans and as called for in these Specifications. The new membrane must come with factory 20 year puncture warranty. This work shall include all clean-up, labor, materials, tools, machinery, hardware, fasteners, caulk, paint, and any and all items required for the complete re-roofing of the Maintenance Annex Building complete, in place, and functional. All existing roof penetrations, riglets, and pitch pans to be waterproofed as required by roofing manufacturer. New gutters and down spouts will be supplied and installed. Existing recessed gutters and down spouts will be covered and abandoned.

EXISTING CONDITION

The existing roof is a Metal Standing Seam Roof with recessed gutter system to the southwest of the building and exterior gutters to the northeast side of the building. Materials from the roof or any other material dislodged from the roof during the roof installation becomes the property of the Contractor and shall be disposed of in accordance with all laws, permits, and/or regulating which may apply.

NEW ROOF INSULATION

Flutes shall be filled with EPS insulation panels, shall be supplied, installed, and anchored in accordance with roof manufacturer's requirements.

GUTTERS

Recessed gutters on southwest side of building will be abandoned and relocated to exterior existing wall panel as detailed on the Plans and as called for in these Specifications. (See Detail 2/A1.1 and 3/A1.1) Existing exposed gutters on northeast side will be removed and replaced with new gutters and downspouts.

ROOF DESCRIPTION

New Roof System shall be TPO Single-Ply Membrane, mechanically attached or equal, TAN, minimum 45-mil thickness, prefab flashing, and heat welded, or approved equivalent.

- A. Roofing System:
 - 1. Membrane: Thermoplastic Polyolefin (TPO).
 - 2. Thickness: 45-mil
 - 3. Membrane Attachment: Fully Adhered.
 - 4. Comply with applicable local building code requirements.
 - 5. Provide assembly having Underwriters Laboratories, Inc. (UL) Class A Fire Hazard Classification.

- B. Insulation:
 - 1. Attachment: Mechanical fastening.

PROTECTION OF EXISTING FACILITIES

- A. The Contractor is advised that the work is to be performed on existing occupied buildings, and Contractor is responsible for protecting existing facilities and occupants against damage or injury from his workmen, work in progress, or the elements.

- B. All flashings shall be installed concurrently with the roof membrane in order to maintain a watertight condition as the work progresses. When a break in the day's work occurs in the central area of a roof, a temporary waterstop shall be constructed to provide a 100% watertight seal. When work on the new system is suspended, the stagger of the insulation joints shall be maintained by installing partial fillers. The new membrane shall be carried into the waterstop. The waterstop shall be sealed to the deck and/or substrate so that water will not be allowed to travel under the new or existing roofing. The edge of the membrane shall be sealed in a continuous heavy application of roof cement of 6" in width. When work resumes, the contaminated membrane shall be cut out. All sealant, contaminated membrane, insulation fillers, etc. shall be removed from the work area and disposed of off site. None of these materials shall be used in the new work.

- C. If inclement weather occurs while temporary waterstop is in place, the Contractor shall provide the labor necessary to monitor the situation to maintain a watertight condition.

- D. If any water is allowed to enter under the newly completed roofing, the affected area shall be removed and replaced at the Contractor's expense.

MATERIAL AND CONSTRUCTION METHODS

A. GENERAL:

1. The roofing membrane manufacturer shall have extensive experience in producing TPO Single-Ply Membrane.
2. Manufacturer may submit components to be used that are other than those supplied or manufactured by manufacturer for review and acceptance.

B. APPROVED MEMBRANE:

1. TPO Single-Ply 45 mil nominal thickness, polyester-reinforced membrane.

INSTALLATION

New 1½" rigid insulation to be placed with staggered joints and mechanically secured per manufacturer's recommendations. The intent is to produce a smooth surface for the membrane roof. The New Membrane roof is to be laid, anchored, welded, etc. in accordance with manufacturer's recommendations, and per details on the plans.

FINISHING AND WALKWAY INSTALLATION

Contractor must install walkways at access points to the roof, along gutters, and around rooftop equipment that may require maintenance.

INSTALLER'S GUARANTEE

- A. An Installer's Guarantee for a period of two (2) years shall be furnished to the Arkansas State Highway and Transportation Department (Owner) upon completion of all work and as a condition to its acceptance and final payment.
- B. Installer's Guarantee shall be issued on Prime Contractor's printed letterhead, agreeing to correct all leaks and defects in the roofing system to the satisfaction of the Owner and the manufacturer of the installed roof system.
- C. During the two (2) year guarantee period, the Roofing Installer shall, upon notice from the Owner, respond promptly to determine the source of leaks or defects and to repair leaks or defects at no cost to Owner.
- D. Regardless of the cause of the leak or defect, the Owner and the Roofing Installer shall document and correspond as to the problem, location and corrective action needed or taken to prevent future similar occurrences.

INSTALLER'S WARRANTY SIGNS

- A. Furnish and install roof Warranty Sign, 10" x 14" (minimum) size, .040" thickness aluminum. Sign shall read:

DO NOT MAKE REPAIRS OR ALTERATIONS TO THIS ROOF WITHOUT THE WRITTEN APPROVAL FROM THE OWNER OR AUTHORIZED REPRESENTATIVE. THE ROOF IS MAINTAINED UNTIL (insert the month and two (2) years after the date of final acceptance) BY (insert Contractor's name, address, and telephone number).

- B. Permanently post Sign where directed by the Owner's representative, prior to submission of and as a condition for final payment.

MANUFACTURER'S GUARANTEE

- A. GENERAL – Specified work shall be guaranteed by the roofing materials manufacturer for a period of not less than Twenty (20) years, with full cost of replacement per square liability sum available starting from date of final acceptance by the Owner of the completed roofing systems.
- B. The Guarantee shall be issued and approved by the materials manufacturer. Surety Company Bonds are not acceptable. Submit two (2) copies of the signed and approved Roof Guarantee, on manufacturer's standard printed form, to the Owner. This is a requirement for final payment of the project.
- C. Specified work shall be inspected by a qualified representative of the manufacturer during its installation and at final completion, for conformance to Manufacturer's Guarantee program. A follow-up inspection shall be made by the manufacturer, sixty (60) days prior to expiration of Installer's two (2) year guarantee.
- D. INSTALLER'S RESPONSIBILITIES - Installer shall notify the roofing materials manufacturer's representatives before commencing any work, review the project requirements with the manufacturer's representatives prior to bidding, pay all required fees, secure all required inspections and do all things necessary to secure and deliver to the Owner the specified Guarantee from the manufacturer of the approved materials.
- E. During the Guarantee period, the manufacturer shall, upon written notice from the Owner, investigate, report, and if covered by Guarantee, permanently restore roof to watertight condition under terms of the Guarantee, within thirty (30) days. Regardless of the cause of the leak or defect, the Owner and the Roofing Manufacturer shall document the problem location and corrective action needed or taken to prevent future similar occurrences.

F. GENERAL DESCRIPTION OF THE ROOF SYSTEM TO BE COVERED BY THE TERMS OF THE MANUFACTURER'S ROOF GUARANTEE - The manufacturer and/or installer will make repairs necessary to correct roof leaks resulting from the following causes:

1. Premature deterioration of part of the roofing system as a result of ordinary wear and tear by the elements.
2. Improper workmanship on the part of the roofing installer.
3. Blisters, bare spots, fish mouths, wrinkles, ridges, splits, or open seams not occasioned by structural failure of the roof deck or its supporting members.
4. Slippage of any part of the roofing system.
5. Breaks in flashing not occasioned by failure of any work.

ACCEPTABLE MANUFACTURERS

- A. Reputable Manufacturers of roofing products doing business in this region who produce a complete line of compatible products for the installation of "Membrane Roofing System", able to provide all components of the roof system as specified and provide the Owner with a manufacturer's guarantee as specified.
- B. All materials on the job shall be used from original manufacturer's containers, clearly labeled with manufacturer's information as required for determination of compliance with these Specifications. All roofing materials shall be the products of, or approved by the manufacturer of the roofing system specified and used.
- C. All roofing and flashing systems shall comply with the manufacturer's latest published manual for the designated slope and type of substrate and shall meet or exceed the manufacturer's requirement for guaranteeing the application.

METHOD OF MEASUREMENT

Roof complete, in place and operating, as called for in these Specifications, as indicated on the Plans, or as directed by the Engineer and accepted, will be measured for payment by the "Lump Sum".

BASIS OF PAYMENT

Work completed and accepted under this item and measured as provided above, will be paid for at the lump sum price bid for Roof Installation", which price shall be full compensation for all materials, labor, tools, equipment, machinery, caulking, drayage, rigging, fees, permits, clean-up, guarantees and any and all incidental items required to complete the work.

PAY ITEM

PAY UNIT

Roof Installation

Lump Sum

**ARKANSAS STATE HIGHWAY AND TRANSPORTATION DEPARTMENT
 CONSTRUCTION PLANS FOR:
 MAINTENANCE / SIGN SHOP
 ROOF RENOVATION
 LITTLE ROCK, ARKANSAS
 PULASKI COUNTY**



**MAINTENANCE / SIGN
 SHOP ROOF RENOVATION**
 Little Rock, Arkansas
 Pulaski County

JOB 42-84

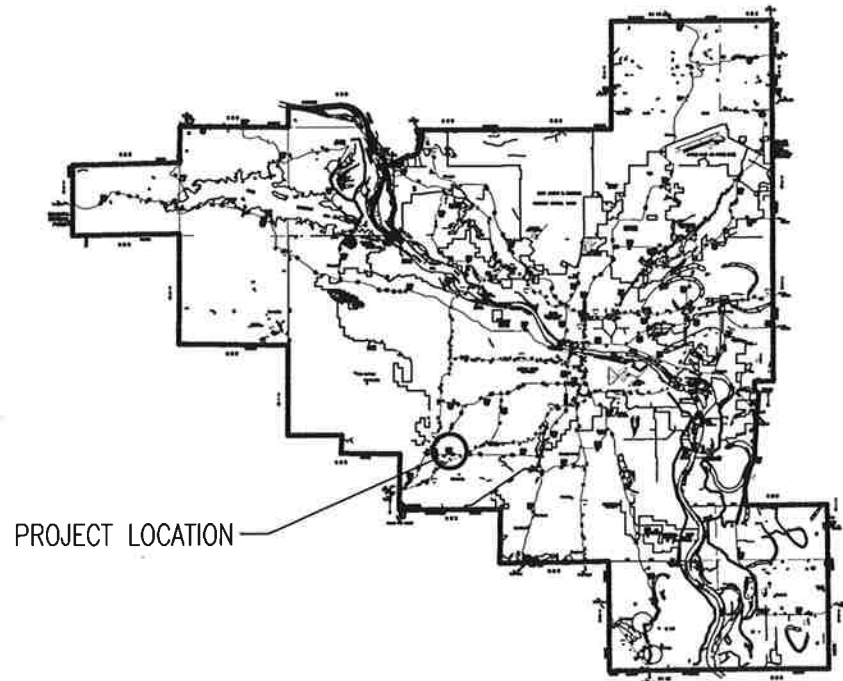

PROJECT LOCATION

COUNTY MAP

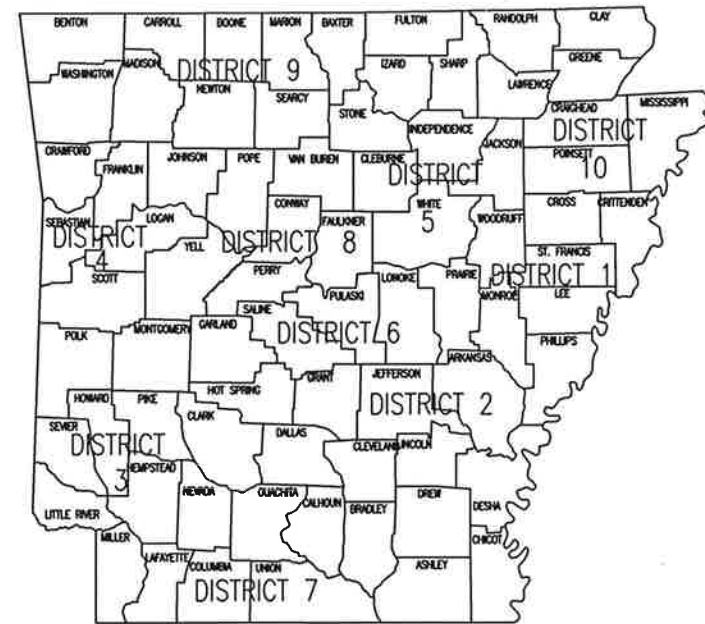

ARK. HWY. DIST. NO. 6



PROJECT LOCATION
 911 ADDRESS:
 11300 WEST BASELINE RD
 LITTLE ROCK, AR 72203

VICINTY MAP

DATE: SEPT. 5, 2014
 JOB NO: 42-84
 DRAWN BY: KB
 REVISIONS:

G1.1
 1 OF 4



ABBREVIATIONS

AD	AREA DRAIN	GA	GAUGE
ADA	AMERICANS WITH DISABILITIES ACT	GALV	GALVANIZED
AFF	ABOVE FINISHED FLOOR	INSUL	INSULATION
AFG	ABOVE FINISHED GRADE	INT	INTERIOR
ALUM	ALUMINUM	MAX	MAXIMUM
ANOD	ANODIZED	MBM	METAL BUILDING MANUFACTURER
BOT	BOTTOM	MECH	MECHANICAL
CJ	CONTROL JOINT	MIN	MINIMUM
CLG	CEILING	MTL	METAL
CLR	CLEAR	NIC	NOT IN CONTRACT
CMU	CONCRETE MASONRY UNIT	NO	NUMBER
COL	COLUMN	NOM	NOMINAL
CONC	CONCRETE	OC	ON CENTER
CONT	CONTINUOUS	OPG	OPENING
DEMO	DEMOLITION	PLUMB	PLUMBING
DTL	DETAIL	PLAS. LAM.	PLASTIC LAMINATE
DIA	DIAMETER	PLYD	PLYWOOD
DIM	DIMENSION	PVC	POLYVINYL CHLORIDE
EA	EACH	RBR	RUBBER
EJ	EXPANSION JOINT	RD	ROOF DRAIN
ELEC	ELECTRICAL	REQ	REQUIRED
ELEV	ELEVATION	SIM	SIMILAR
EQ	EQUAL	SPEC	SPECIFICATION
EWC	ELECTRIC WATER COOLER	SPK	SPRINKLER
EXIST	EXISTING	STRUCT	STRUCTURAL
FD	FLOOR DRAIN	T&G	TONGUE AND GROOVE
FEC	FIRE EXTINGUISHER CABINET	TELE	TELEPHONE
FFE	FINISHED FLOOR ELEVATION	TLT	TOILET
FIXT	FIXTURE	TYP	TYPICAL
FLR	FLOOR	UNO	UNLESS NOTED OTHERWISE
		VCT	VINYL COMPOSITION TILE

INDEX OF DRAWINGS

G1.1 - COVER SHEET A1.1 - ROOF PLAN
 G1.2 - SHEET INDEX A2.1 - DETAILS

SYMBOL LEGEND

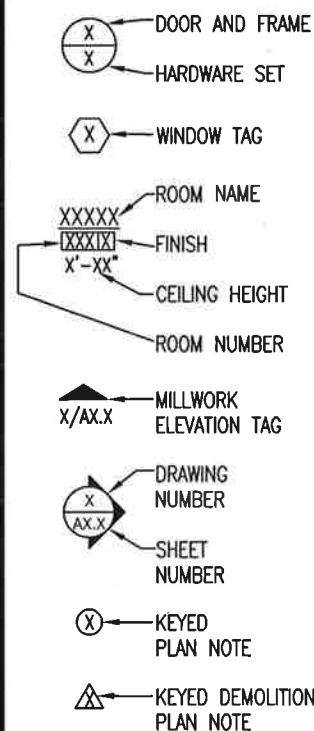

MATERIAL LEGEND

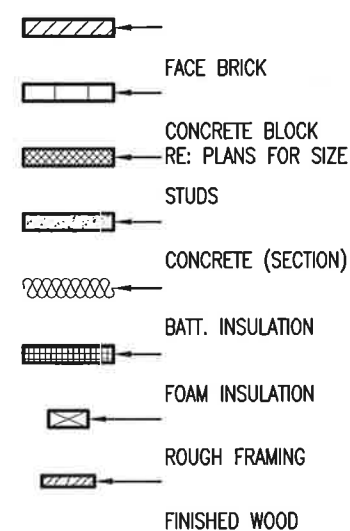

**MAINTENANCE \ SIGN
 SHOP ROOF RENOVATION**
 Little Rock, Arkansas
 Pulaski County

DATE: SEPT. 5, 2014
 JOB NO: 42-84
 DRAWN BY: KB
 REVISIONS:

GOVERNING SPECIFICATIONS:

ARKANSAS STATE HIGHWAY COMMISSION STANDARD SPECIFICATIONS FOR HIGHWAY CONSTRUCTION, EDITION OF 2014

G1.2

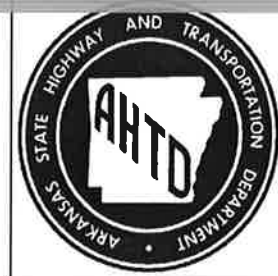

MAINTENANCE \ SIGN
SHOP ROOF RENOVATION
 Little Rock, Arkansas
 Pulaski County

- GENERAL NOTES:
1. ALL EXISTING CONDITIONS TO BE FIELD VERIFIED PRIOR TO BIDDING
 2. SEE DETAIL 1/A1.2 FOR NEW ROOF INSTALLATION
 3. METAL COLORS TO BE SELECTED BY OWNER FROM MFG. STANDARD COLORS

- KEYED NOTES:
1. REMOVE EXISTING GUTTERS AND DOWNSPOUTS.
 2. REMOVE EXISTING SCUPPERS AND DOWNSPOUTS
 3. REMOVE EXISTING RIDGE VENT
 4. REMOVE EXISTING SHEET METAL SKIN ON VERTICAL WALL TO EXPOSE CONCRETE WALL.
 5. REMOVE EXISTING FLASHING AND CAULK AND CLEAN FOR INSTALLATION OF NEW FLASHING
 6. EXTEND ROOF PENETRATIONS AND REMOVE CRICKETS AS REQUIRED FOR INSTALLATION OF NEW FLASHING AND ROOFING
 7. VERIFY WITH OWNER FOR ANY PENETRATIONS TO BE ABANDONED
 8. EXISTING LIGHT TO BE RELOCATED BY OWNER
 9. SEE DETAIL 1/A1.2 FOR NEW ROOF REQUIREMENTS
 10. METAL COLORS TO BE SELECTED BY OWNER FROM MFG. STANDARD COLORS
 11. ALL CONDITIONS TO BE FIELD VERIFIED PRIOR TO BIDDING

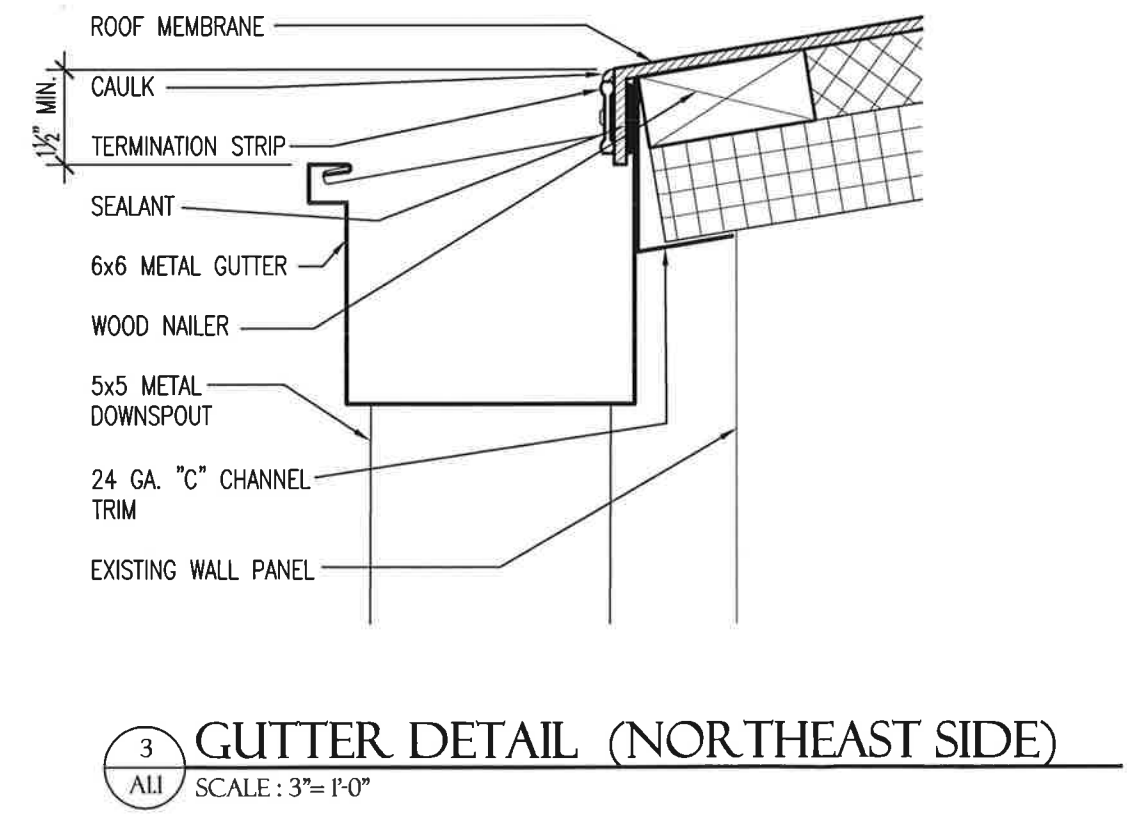
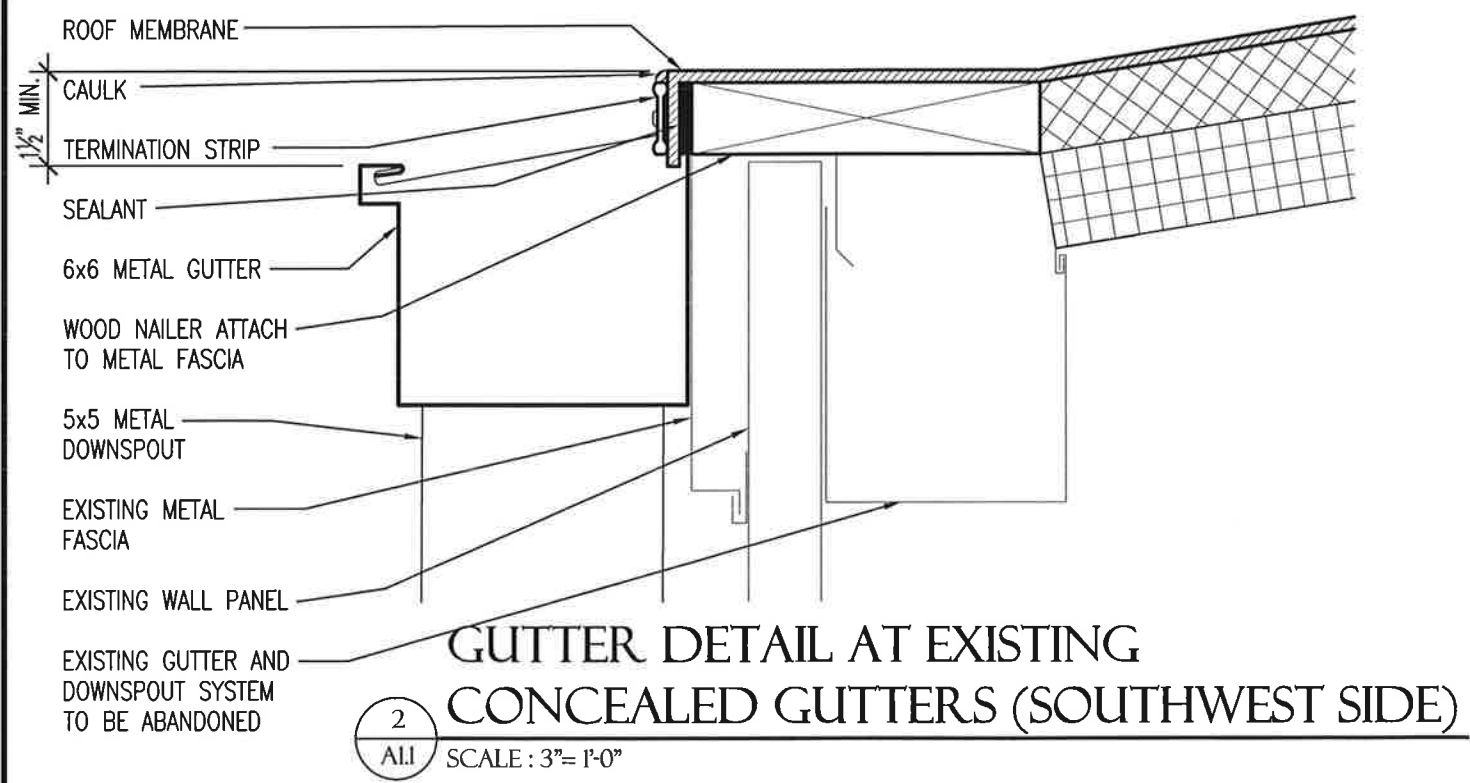
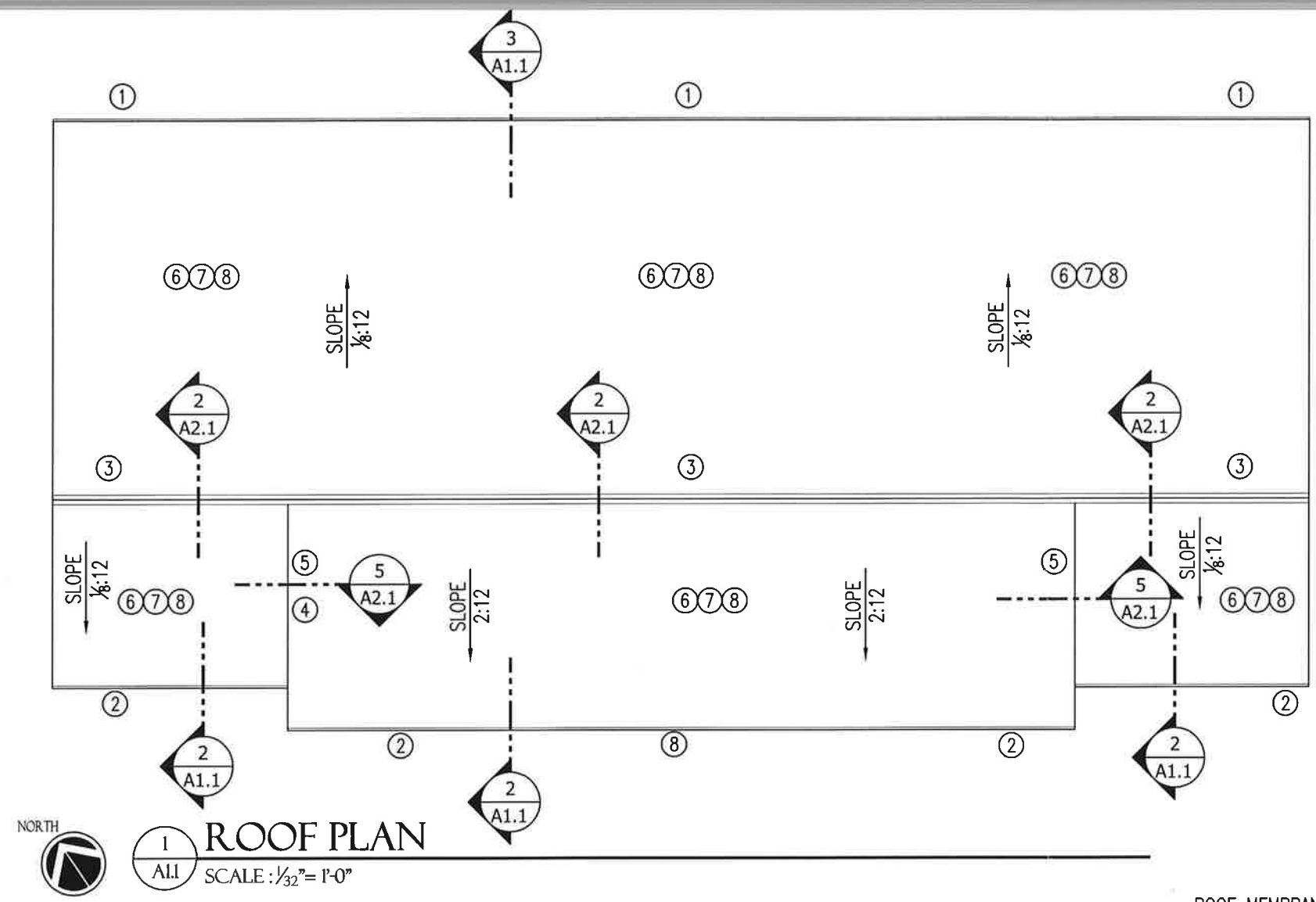

DATE: SEPT. 5, 2014
 JOB NO: 42-84
 DRAWN BY: KB
 REVISIONS:

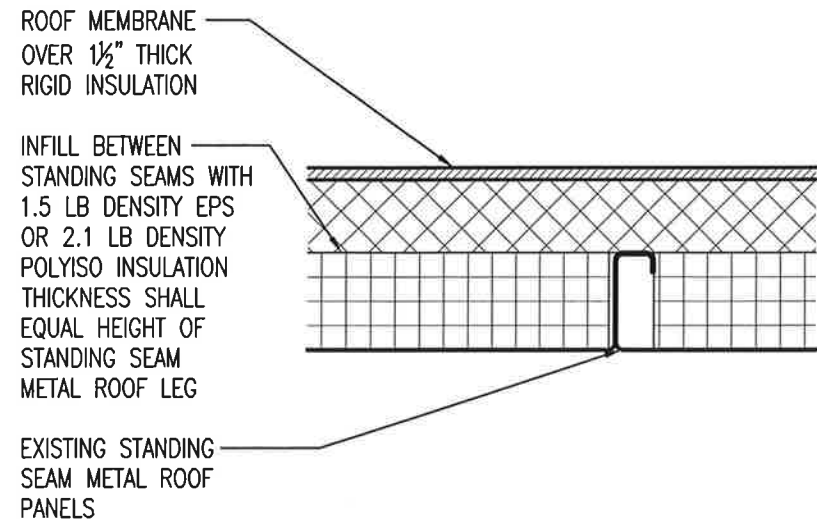

1 INFILL DETAIL
A2.1 SCALE: 3" = 1'-0"

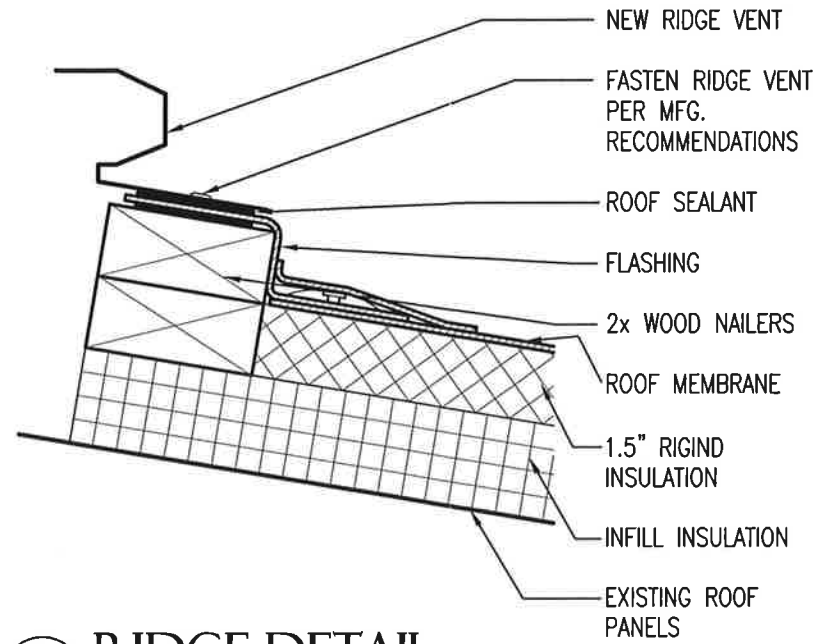

2 RIDGE DETAIL
A2.1 SCALE: 3" = 1'-0"

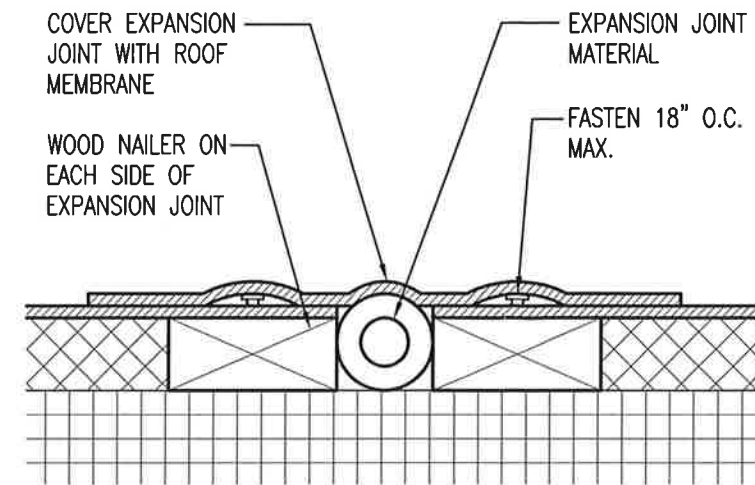

NOTE:
INSTALL EXPANSION JOINTS AS
REQUIRED BY MFG. RECOMMENDATIONS

3 EXPANSION JOINT DETAIL
A2.1 SCALE: 3" = 1'-0"

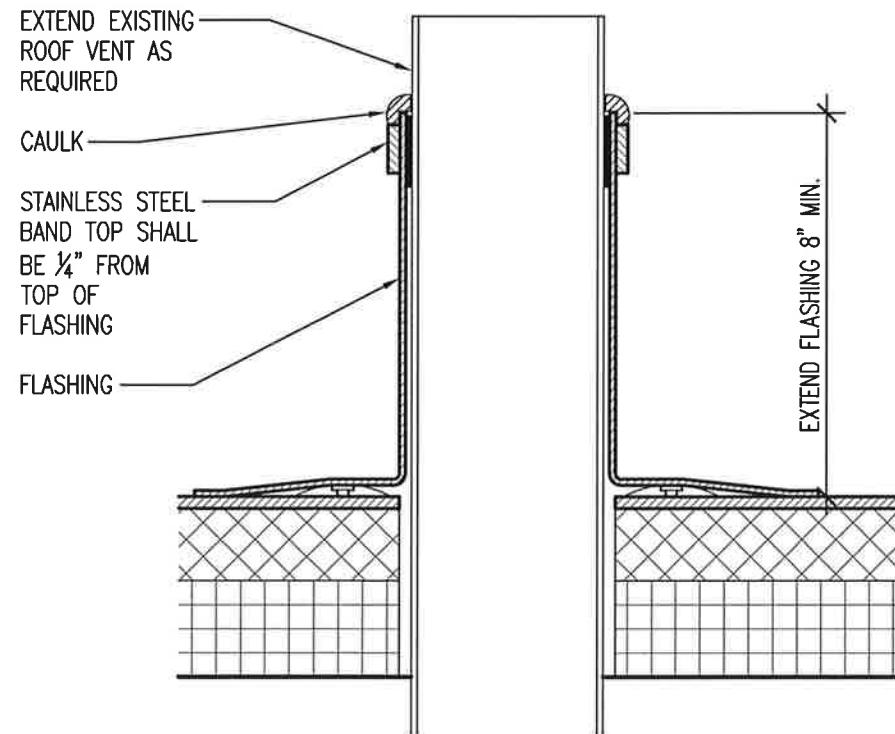

NOTE:
REMOVE EXISTING ROOF VENT
FLASHING BEFORE INSTALLING
NEW ROOF MATERIALS

4 ROOF VENT DETAIL
A2.1 SCALE: 3" = 1'-0"

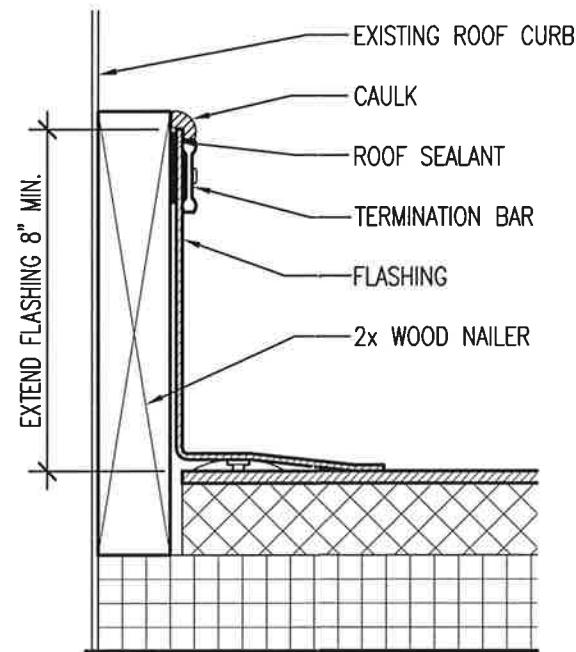

NOTE:
REMOVE EXISTING ROOF CURB
FLASHING BEFORE INSTALLING
NEW ROOF MATERIALS

4 ROOF CURB DETAIL
A2.1 SCALE: 3" = 1'-0"

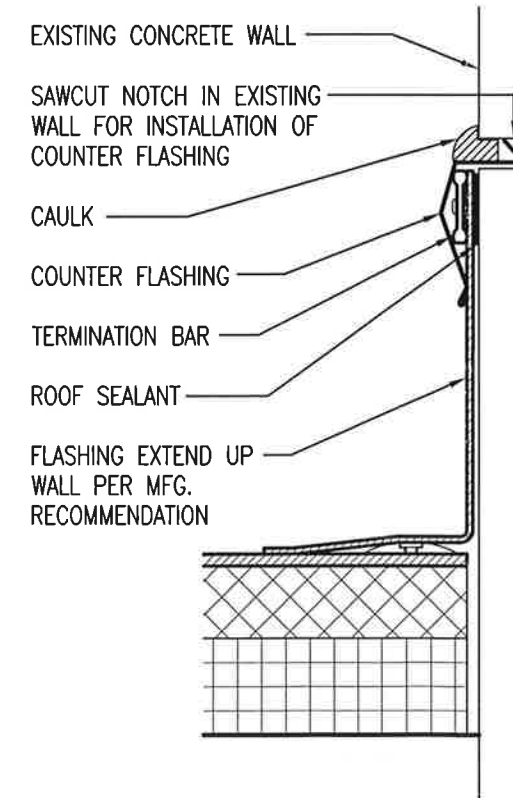

5 WALL FLASHING DETAIL
A2.1 SCALE: 3" = 1'-0"



MAINTENANCE \ SIGN
SHOP ROOF RENOVATION
Little Rock, Arkansas
Pulaski County

DATE: SEPT. 5, 2014
JOB NO: 42-84
DRAWN BY: KB
REVISIONS:

A2.1