

**ARKANSAS STATE HIGHWAY AND TRANSPORTATION DEPARTMENT  
EQUIPMENT AND PROCUREMENT DIVISION  
BID INVITATION**

Contract Number:           H-17-220J          

<b>BID OPENING LOCATION:</b>	<b>MAIL TO:</b>	<b>DELIVER TO:</b>
AHTD Equipment & Procurement Division 11302 West Baseline Road Little Rock, AR 72209	AHTD Equipment & Procurement Division P.O. Box 2261 Little Rock, AR 72203	AHTD Equipment & Procurement Division 11302 West Baseline Road Little Rock, AR 72209

Bid Opening Date:   August 16, 2016   Time:   11:00 a.m.  

Sealed bids for furnishing the commodities and/or services described below, subject to the Conditions on page 2 of this bid invitation will be received at the above-noted mail and delivery locations until the above-noted bid opening date and time, and then publicly opened at the above-noted bid opening location. **Bids must be submitted on this form, with attachments when appropriate, or bids will be rejected. Late bids and unsigned bids will not be considered.**

In compliance with this Bid Invitation and subject to all the Conditions thereof, the undersigned offers and agrees to furnish any and all items upon which prices are quoted, at the price set opposite each item.

Company Name: _____	Name (Type or Print): _____
Address: _____	Title: _____
_____	Phone: _____ Fax: _____
City: _____ State: _____ Zip: _____	E-mail Address: _____
Federal Tax ID or Social Security No.: _____	<b>Signature:</b> _____

Signature must be legible, original (not photocopied) and in ink.  
Unsigned bids will be rejected.

Item No.	Description
3	<p><b>Items – <u>Carbide Tipped Underbody Scraper Blades</u> – delivered to locations listed as per attached sheet.</b></p> <p>Contract may be renewed or extended upon mutual agreement of the parties, but shall not exceed limitations allowed by Arkansas State Procurement Law.</p> <p>The Carbide Tipped Underbody Scraper Blades shall meet Arkansas State Highway and Transportation Department Specifications and Test requirements attached to and made a part of this bid.</p> <p><b><u>ALL OR NONE BIDS ONLY WILL BE CONSIDERED.</u></b></p> <p><b><u>NO FRIDAY DELIVERIES</u></b></p> <p>Blades proposed to furnish: Brand _____</p> <p><b>Bid Bond</b> in the amount of 5% of total bid price required of all bidders at time of bid opening or bid will be rejected. <b><u>Personal and company checks are not acceptable as Bid Bonds.</u></b> See Condition 3 on page 2 of this Bid Invitation.</p> <p><b>Performance Bond</b> in the amount of 5% of total bid price will be required of successful bidder prior to providing goods/services. <b><u>Personal and company checks are not acceptable as Performance Bonds.</u></b> See Condition 3 on page 2 of this Bid Invitation.</p> <p><b>Additional Bonding Requirement:</b> If additional units are purchased from this contract, a separate Performance Bond will be required under the same conditions as stated in this Bid Invitation.</p> <p>The successful bidder will be required to complete delivery within <b>45 days</b> after award.</p> <p>Bids and Specifications are available on-line by going to the AHTD Web Site – <a href="http://www.arkansashighways.com">www.arkansashighways.com</a> and clicking on “Commodities and Services Bids/Contracts Information”. Tabulations will also be available at this site after award of bid/contract. If you have any questions, call this office at 501-569-2667.</p> <p>01-42</p>

**ARKANSAS STATE HIGHWAY AND TRANSPORTATION DEPARTMENT**  
**CARBIDE TIPPED UNDERBODY SCRAPER BLADES**

Cooperative Purchasing: Other tax-supported entities\* in Arkansas (cities, counties, state agencies, school districts, etc.) may purchase commodities covered in this Contract on an individual basis under the same specifications and conditions, and at the pricing set forth by each vendor, all at the discretion of the vendor in each case. Prices could be reduced by a vendor for minor alterations in conditions (changing order quantities) as agreed by both parties, but could not be raised above the contract bid price except for any additional freight charges. Vendor would not be required to sell to any such entity under this contract, and those entities would not be obligated to purchase from the Contract.

Each entity wishing to purchase from the Contract would make contact directly with the vendor. The Highway Department would remain “out of the loop” for such transactions: all contact, orders, invoices, payments, etc. regarding such transactions must take place exclusively between the tax supported entity and the vendor. The Department would be held harmless of any and all liability arising from such transactions.

\*Tax-supported entities are defined as those receiving more than half of total funding from appropriate tax funds.

STANDARD BID CONDITIONSH-17-220J

1. **ACCEPTANCE AND REJECTION:** The Arkansas State Highway and Transportation Department (AHTD) reserves the right to reject any or all bids, to accept bids in whole or in part (unless otherwise indicated by bidder), to waive any informalities in bids received, to accept bids on materials or equipment with variations from specifications where efficiency of operation will not be impaired, and to award bids to best serve the interest of the State.
2. **PRICES:** Unless otherwise stated in the Bid Invitation, the following will apply: (1) unit prices shall be bid, (2) prices should be stated in units of quantity specified (feet, each, lbs., etc.), (3) prices must be F.O.B. destination specified in bid, (4) prices must be firm and not subject to escalation, (5) bid must be firm for acceptance for 30 days from bid opening date. In case of errors in extension, unit prices shall govern. Discounts from bid price will not be considered in making awards.
3. **BID BONDS AND PERFORMANCE BONDS:** If required, a **Bid Bond** in the form of a cashier's check, certified check, or surety bond issued by a surety company, in an amount stated in the Bid Invitation, must accompany bid. **Personal and company checks are not acceptable as Bid Bonds.** Failure to submit a Bid Bond as required will cause a bid to be rejected. The Bid Bond will be forfeited as liquidated damages if the successful bidder fails to provide a required Performance Bond within the period stipulated by AHTD or fails to honor their bid. When a bidder claims and can show clear and convincing evidence that a material mistake was made in the bid and was not the bid intended, the bidder may be permitted to withdraw their bid prior to award without forfeiture of bid bond. Cashier's checks and certified checks submitted as Bid Bonds will be returned to unsuccessful bidders; surety bonds will be retained. The successful bidder will be required to furnish a **Performance Bond** in an amount stated in the Bid Invitation and in the form of a cashier's check, certified check, or surety bond issued by a surety company, unless otherwise stated in the Bid Invitation, as a guarantee of delivery of goods/services in accordance with the specifications and within the time established in the bid. **Personal and company checks are not acceptable as Performance Bonds.** In some cases, a cashier's check or certified check submitted as a Bid Bond will be held as the Performance Bond of the successful bidder. Cashier's checks or certified checks submitted as Performance Bonds will be refunded shortly after payment has been made to the successful bidder for completion of all terms of the bid; surety bonds will be retained. Surety bonds must be issued by a surety company authorized to do business in Arkansas, and must be signed by a Resident Local Agent licensed by the Arkansas State Insurance Commissioner to represent that surety company. Resident Agent's Power-of-Attorney must accompany the surety bond. Certain bids involving labor will require Performance Bonds in the form of surety bonds only (no checks of any kind allowed). These bonds shall not only serve to guarantee the completion of the work, but also to guarantee the excellence of both workmanship and material until the work is finally accepted and the provisions of the Plans, Specifications, and Special Provisions fulfilled. In such cases, the company issuing the surety bond must comply with all stipulations herein and must be named in the U. S. Treasury listing of companies holding Certificates of Authority as acceptable sureties on Federal Bonds and as acceptable reinsuring companies. Any excess between the face amount of the bond and the underwriting limitation of the bonding company shall be protected by reinsurance provided by an acceptable reinsuring company. Annual Bid and Performance Bonds on file with E & P Division must have sufficient unencumbered funds to meet current bonding requirements, or the bid will be rejected, unless the balance is submitted as set forth above, prior to bid opening.
4. **TAXES:** The AHTD is not exempt from Arkansas State Sales and Use Taxes, or local option city/county sales taxes, when applicable, and bidders are responsible to the State Revenue Department for such taxes. These taxes should not be included in bid prices, but where required by law, will be paid by the AHTD as an addition thereto, and should be added to the billing to the AHTD. The AHTD is exempt from Federal Excise Taxes on all commodities except motor fuels; and excise taxes should not be included in bid prices except for motor fuels. Where applicable, tax exemption certificates will be furnished by the AHTD.
5. **"ALL OR NONE" BIDS:** Bidders who wish to bid "All or None" on two or more items shall so stipulate on the face of bid sheet; otherwise, bid may be awarded on an individual item basis.
6. **SPECIFICATIONS:** Complete specifications should be attached for any substitution or alternate offered, or where amplification is necessary. Bidder's name must be placed on all attachments to the bid.
7. **EXCEPTIONS TO SPECIFICATIONS:** Any exceptions to the bid specifications must be stated in the bid. Any exceptions to manufacturer's published literature must be stated in the bid, or it will be assumed that bidder is bidding exactly as stated in the literature.
8. **BRAND NAME REFERENCES:** All brand name references in bid specifications refer to that commodity or its equivalent, unless otherwise stated in Bid Invitation. Bidder should state brand or trade name of item being bid, if such name exists.
9. **FREIGHT:** All freight charges should be included in bid price. Any change in common carrier rates authorized by the Interstate Commerce Commission will be adjusted if such change occurs after the bid opening date. Receipted common carrier bills that reflect ICC authorized rate changes must be furnished.
10. **SAMPLES, LITERATURE, DEMONSTRATIONS:** Samples and technical literature must be provided free of any charge within 14 days of AHTD request, and free demonstrations within 30 days, unless AHTD extends time. Failure to provide as requested within this period may cause bid to be rejected. Samples, literature and demonstrations must be substantially the same as the item(s) being bid, unless otherwise agreed to by AHTD. Samples that are not destroyed will be returned upon request at bidders expense. Samples from successful bidders may be retained for comparison with items actually furnished.
11. **GUARANTY:** Unless otherwise indicated in Bid Invitation, it is understood and agreed that any item offered or shipped on this bid shall be newly manufactured, latest model and design, and in first class condition; and that all containers shall be new, suitable for storage or shipment and in compliance with all applicable laws relating to construction, packaging, labeling and registration.
12. **BACKORDERS OR DELAY IN DELIVERY:** Backorders or failure to deliver within the time required may constitute default. Vendor must give written notice to the AHTD, as soon as possible, of the reason for any delay and the expected delivery date. The AHTD has the right to extend delivery if reasons appear valid. If reason or delivery date is not acceptable, vendor is in default.
13. **DEFAULT:** All commodities furnished will be subject to inspection and acceptance by AHTD after delivery. Default in promised delivery or failure to meet specifications authorizes the AHTD to cancel award or any portion of same, to reasonably purchase commodities or services elsewhere and to charge full increase, if any, in cost and handling to defaulting vendor. Applicable bonds may be forfeited.
14. **ETHICS:** *"It shall be a breach of ethical standards for a person to be retained, or to retain a person, to solicit or secure a State contract upon an agreement of understanding for a commission, percentage, brokerage, or contingent fee, except for retention of bona fide employees or bona fide established commercial selling agencies maintained by the contractor for the purpose of securing business."* (Arkansas Code, Annotated, Section 19-11-708).

# ARKANSAS STATE HIGHWAY AND TRANSPORTATION DEPARTMENT

## NOTICE OF NONDISCRIMINATION

The Arkansas State Highway and Transportation Department (Department) complies with all civil rights provisions of federal statutes and related authorities that prohibit discrimination in programs and activities receiving federal financial assistance. Therefore, the Department does not discriminate on the basis of race, sex, color, age, national origin, religion (not applicable as a protected group under the Federal Motor Carrier Safety Administration Title VI Program), disability, Limited English Proficiency (LEP), or low-income status in the admission, access to and treatment in the Department's programs and activities, as well as the Department's hiring or employment practices. Complaints of alleged discrimination and inquiries regarding the Department's nondiscrimination policies may be directed to Joanna P. McFadden Section Head – EEO/DBE (ADA/504/Title VI Coordinator), P. O. Box 2261, Little Rock, AR 72203, (501)569-2298, (Voice/TTY 711), or the following email address: [joanna.mcfadden@ahtd.ar.gov](mailto:joanna.mcfadden@ahtd.ar.gov)

Free language assistance for Limited English Proficient individuals is available upon request.

This notice is available from the ADA/504/Title VI Coordinator in large print, on audiotape and in Braille.

ARKANSAS STATE HIGHWAY & TRANSPORTATION DEPARTMENT  
LITTLE ROCK, ARKANSAS  
EQUIPMENT & PROCUREMENT DIVISION  
CARBIDE TIPPED UNDERBODY SCRAPER BLADES

Page 1 of 1

Contract No. H-17-220J

BIDDER: \_\_\_\_\_

ITEM NO.	DESCRIPTION	QUANTITY	UNIT	PRICE	AMOUNT
----------	-------------	----------	------	-------	--------

Items 1 & 2 – FOB: District 6 Headquarters, 8900 Mabelvale Pike  
Little Rock, AR 72209 (36-0182).

1.	3' x 7/8" x 5" with 5/8" Holes	100	ea.	\$ _____	\$ _____
2.	4' x 7/8" x 5" with 5/8" Holes	100	ea.	\$ _____	\$ _____

Items 3 – FOB: District 9 Headquarters, 4590 Hwy. 65 South,  
Harrison, AR 72601 (39-0217).

3.	4' x 7/8" x 5" with 5/8" Holes	10	ea.	\$ _____	\$ _____
----	--------------------------------	----	-----	----------	----------

BID TOTAL: \_\_\_\_\_

**Additional Units may be purchased at the same pricing and conditions through \_\_\_\_\_  
(Date)**

ARKANSAS STATE HIGHWAY AND TRANSPORTATION DEPARTMENT

**CARBIDE TIPPED UNDERBODY SCRAPER BLADES**

**1.0 SCOPE.**

This specification covers steel underbody scraper blades with tungsten carbide inserts.

**2.0 MATERIALS.**

**2.1 Steel.** The blades shall be fabricated from hot rolled carbon steel meeting the requirements of ASTM A 576-90b or ASTM A 575-96 within the range of Grades 1020 through 1044.

**2.2 Tungsten Carbide Inserts.** The inserts shall be a high shock WC Grade of tungsten carbide.

**2.2.1** The inserts shall meet Virgin Tungsten Carbide quality specifications and shall meet the following requirements;

**Cobalt Content: 11.0 % to 12.5%** when tested in accordance with Section 4.0 of these specifications.

Density: 14.1 g/m<sup>3</sup> to 14.6 g/m<sup>3</sup> when tested in accordance with ASTM B 311-93

Hardness: 87.0 to 89.0 when tested in accordance with ASTM B 294-92, Rockwell A Scale.

**Transverse Rupture Strength: 350,000 psi minimum.**

**2.2.2** The inserts shall be trapezoid design of the following dimensions:

Height 0.635" ± 0.005" (long side)

Width 0.360" ± 0.005" minimum.

Length 1" Nominal

Bottom Angle 25 degrees with a nose radius of 0.06" minimum.

**2.3 Finished Blades.**

**2.3.1** Insert Placement. The groove for the carbide shall be milled in the center of the steel blade edge. The tungsten carbide inserts shall be positioned in the milled groove with approximately 0.010 inch space between the inserts the entire length of each cutting edge section. Each insert shall be one inch nominal length. It may be necessary for some of the inserts to be different than the one inch nominal to make up for the spacing between the inserts. The number of inserts shall be no less than one or more than three from the number required for one insert per inch of blade length.

**2.3.2** Brazing. The inserts shall be brazed on all sides consistent with sound brazing practice with no evidence of voids or use of shims. Brazing shall be of such strength and quality as required to prevent movement or loss of the inserts during use.

**2.3.3** Physical Requirements. All blades shall be straight and free from flaws and injurious defects, and shall have workmanlike finish.

**2.3.3.1** The finished blade sections shall be free of warpage and longitudinal deviation shall not exceed 1/8 inch in a four foot long blade section or 3/32 inch in a three foot long blade section. The edge that rests upon the pavement shall be straight and true. The longitudinal warp and

the alignment of this edge shall be measured by extending a straight edge from one end of the blade to the other and measuring from the straight edge to the blade at the mid-point of length.

**2.3.3.2** The difference between the highest and lowest tip point shall not exceed 1/32 inch on any given blade assembly.

**2.3.3.3** Punching shall be 11/16 inch square holes with a 1 5/32 inch diameter countersink 1/8" to 3/16" inch deep to receive 5/8 inch diameter plow bolts. Details, location, and spacing of the holes shall be as shown on the attached drawing. Hole punch arrangement on three foot blades shall be as follows, 3-3-12-12-3-3. Hole punch arrangement on four foot blade shall be as follows, 3-3-12-12-12-3-3.

**2.3.3.4** Moldboards are punched with holes 1/8 inch larger than the blade bolts. Accordingly, blade punching will be of such accuracy, both for the spacing between holes and for the spacing between the end hole and the end of the blade, that the blades will fit the moldboards, thus making the blade sections interchangeable.

**2.3.3.5** Blades shall be of top bevel design to accommodate mounting on any moldboard. Bevel shall be 32 degrees.

**2.3.3.6** A strip of high carbon hard surface weld shall be applied to the front, bottom edge of the blade and run the full length of the blade. This strip shall be a minimum of 7/8 inch high and a minimum of 3/16 inch thick.

### **3.0 CERTIFICATION AND ACCEPTANCE.**

**3.1** Prior to approval and use of any material delivered, the manufacturer shall submit to Mr. Michael Benson, Material Engineer, Materials Divisions, P. O. Box 2261, Little Rock, Arkansas 72203, a certification in triplicate certifying the grade of steel used in fabricating the blade and certifying that the blades supplied conform to all requirements of these specifications.

**3.1.1** The "Certification Statement" form shown in Section 5.0 is to be used when certifying. The certification shall include or have attached specific results of test performed on the tungsten carbide inserts for cobalt content, density, and hardness and showing the standard test designation of the test specified for each of these properties. The certification shall show the purchase order number, destination, quantity of material represented at each destination and shipping date.

**3.2** Acceptance of the blades and carbide tip inserts shall be based on the manufacturer's certification and upon the results of such tests as may be performed on samples of the material. When samples are taken one complete blade of each length shall be taken to represent the shipment. A shipment will be considered as all blades represented on one certification and shipped on one date, regardless of various destinations. The carbide tip inserts shall be sampled from the blades selected for testing.

**3.2.1** If a blade fails to meet any of the specified requirements, two additional blades will be selected for retest from the same quantity represented by that certification. Both of these retest samples must meet all requirements or the entire quantity will be rejected.

**3.2.2** If the carbide tip inserts fail to meet any of the specified requirements, two additional samples will be selected either from the original blade sampled or from other blades contained in the same quantity represented by that certification. Both of these retest samples must meet all requirements or the entire quantity will be rejected.

**3.3** If the blades are rejected, no payment will be made and the cost of blades destroyed during sampling and testing shall be borne by the supplier.

### **4.0 DETERMINATION OF COBALT IN TUNGSTEN CARBIDE INSERTS**

#### 4.1. SCOPE

4.1.1 This method describes a procedure for determining the percent of Cobalt in Tungsten Carbide Inserts used in Snow Plow Blades, using Atomic Absorption Spectrophotometry.

#### 4.2. EQUIPMENT AND REAGENTS

- 4-2.1 An Atomic Absorption Spectrophotometer.
- 4.2.2 Hydrofluoric Acid (HF), 48 percent
- 4.2.3 Nitric Acid (HNO<sub>3</sub>), specific gravity 1.42
- 4-2.4 Hydrochloric Acid (HCl), specific gravity 1.19
- 4.2.5 Sulfuric Acid (H<sub>2</sub>SO<sub>4</sub>), specific gravity 1.84
- 4.2.6 Ammonium Hydroxide (NH<sub>4</sub>OH), specific gravity 0.90
- 4.2.7 Sodium Chloride (NaCl), Reagent Grade

#### 4.3. PREPARATION OF STANDARDS

4.3.1 1000 ppm Cobalt stock solution:

This solution can be purchased from a number of sources, or it can be prepared in the laboratory from a suitably pure Cobalt salt.

4.3.2 8.00 % Cobalt standard solution: Weigh 6.00 g. NaCl into a 1000 mL volumetric flask. Add approximately 250 mL distilled water to dissolve the NaCl and then add 5 mL H<sub>2</sub>SO<sub>4</sub>, 5 ml 1:1 NH<sub>4</sub>OH, and 10 mL 1 HCl. Pipette 20.00 mL of 1000 ppm Cobalt stock solution into the flask and dilute to volume with 1:99 HCl. This solution is equivalent to 8.00% cobalt.

4.3.3 16.00% Cobalt standard solution: Weigh 6.00 g. NaCl into a 1000 mL volumetric flask. Add approximately 250 ml distilled water to dissolve the NaCl and then add 5 mL H<sub>2</sub>SO<sub>4</sub>, 5 mL 1:1 NH<sub>4</sub>OH, and 10 mL. HCl. Pipette 40.00 mL of 1000 ppm Cobalt stock solution into the flask and dilute to volume with 1:99 HCl. This solution is equivalent to 16.00% cobalt.

4.3.4 Blank solution: Prepare a blank by the same procedure used to prepare the 16.00% Cobalt standard, omitting the addition of 40 mL of Cobalt stock solution.

#### 4.4. PROCEDURE

4.4.1 Crush or grind an insert until approximately half of the particles (20-25 grams) will pass a No. 20 sieve. Weigh, to the nearest 0.1 mg., 0.248 to 0.250 grams of the material passing the No. 20 sieve, and place in a platinum crucible having a volume of 25-35 mL. Add 10 mL of HF and 2 or 3 drops of HNO<sub>3</sub>. Cover the crucible immediately and heat gently. Add 2 or 3 drops of HNO<sub>3</sub> each time the reaction subsides, keeping the crucible covered as much as possible. When solution of the sample is complete, remove the cover, rinse with H<sub>2</sub>O, and cool to room temperature. Carefully add 5 mL H<sub>2</sub>SO<sub>4</sub> and evaporate to dense white fumes. Transfer to a 400 mL beaker and rinse crucible with H<sub>2</sub>O, transferring as much precipitate as possible to the beaker. Place 5 ml of 1:1 NH<sub>4</sub> OH in the crucible and warm gently to dissolve the remainder of the precipitate and add to the contents of the beaker. Rinse the crucible once with H<sub>2</sub>O and then once with 1:99 HCl and finally with H<sub>2</sub>O. Add 6.00 g. NaCl to the contents of the beaker and dilute to approximately 250 mL with H<sub>2</sub>O. Add 10 mL HCl, boil vigorously about 5 minutes and then digest 30 minutes at low heat. Filter on Whatman No. 42 paper into a 1000 mL volumetric flask, washing 10-12 times with hot 1:99 HCl. Cool and dilute to volume with 1:99 HCl.

4.4.2 Calibrate the instrument - using the blank solution, the 8.00% standard solution and the 16.00% standard solution, then determine the concentration of the sample solution.



#### **4.5. CALCULATION AND REPORT**

4.5.1 The method of calculating the percent Cobalt in the sample will vary with the make and model of instrument used. Report the Cobalt in the sample to the nearest 0.1% as follows:

% Cobalt (Co)

**ARKANSAS HIGHWAY and TRANSPORTATION DEPARTMENT  
CERTIFICATION STATEMENT**

**CARBIDE TIPPED UNDERBODY SCRAPER BLADES**

Mr. Michael Benson  
Materials Engineer  
Materials Division  
P. O. Box 2261  
Little Rock, Arkansas 72203

Dear Mr. Micheal Benson

Certification Statement.

We hereby certify that the carbide tipped snow plow blades described below comply with all requirements of the Specification for Carbide Tipped Snow Plow Blades and in accordance with Bid Request No.

\_\_\_\_\_ .

The following blades manufactured by \_\_\_\_\_ are covered by this certification.

<b>Purchase Order No.</b>	<b>Destination</b>	<b>Quantity &amp; Size</b>	<b>Shipping Date</b>
_____	_____	_____	_____
_____	_____	_____	_____
_____	_____	_____	_____
_____	_____	_____	_____

Following are results of tests performed on these blades:

Grade of Steel in the Blade: \_\_\_\_\_

Cobalt Content in Carbide Tip: \_\_\_\_\_ Test Method: \_\_\_\_\_

Density of Carbide Tip: \_\_\_\_\_ Test Method: \_\_\_\_\_

Hardness of Carbide Tip: \_\_\_\_\_ Test Method: \_\_\_\_\_

Certified By: \_\_\_\_\_ Date: \_\_\_\_\_

Title: \_\_\_\_\_

Results of tests may be shown on attachments rather than on this form, if preferred.

This form is to be completed, signed, and submitted in triplicate for each shipment, at the same time as blades are shipped. A shipment is defined all blades represented an one certification and shipped on one date, regardless of various destinations.

Arkansas Highway & Transportation Department

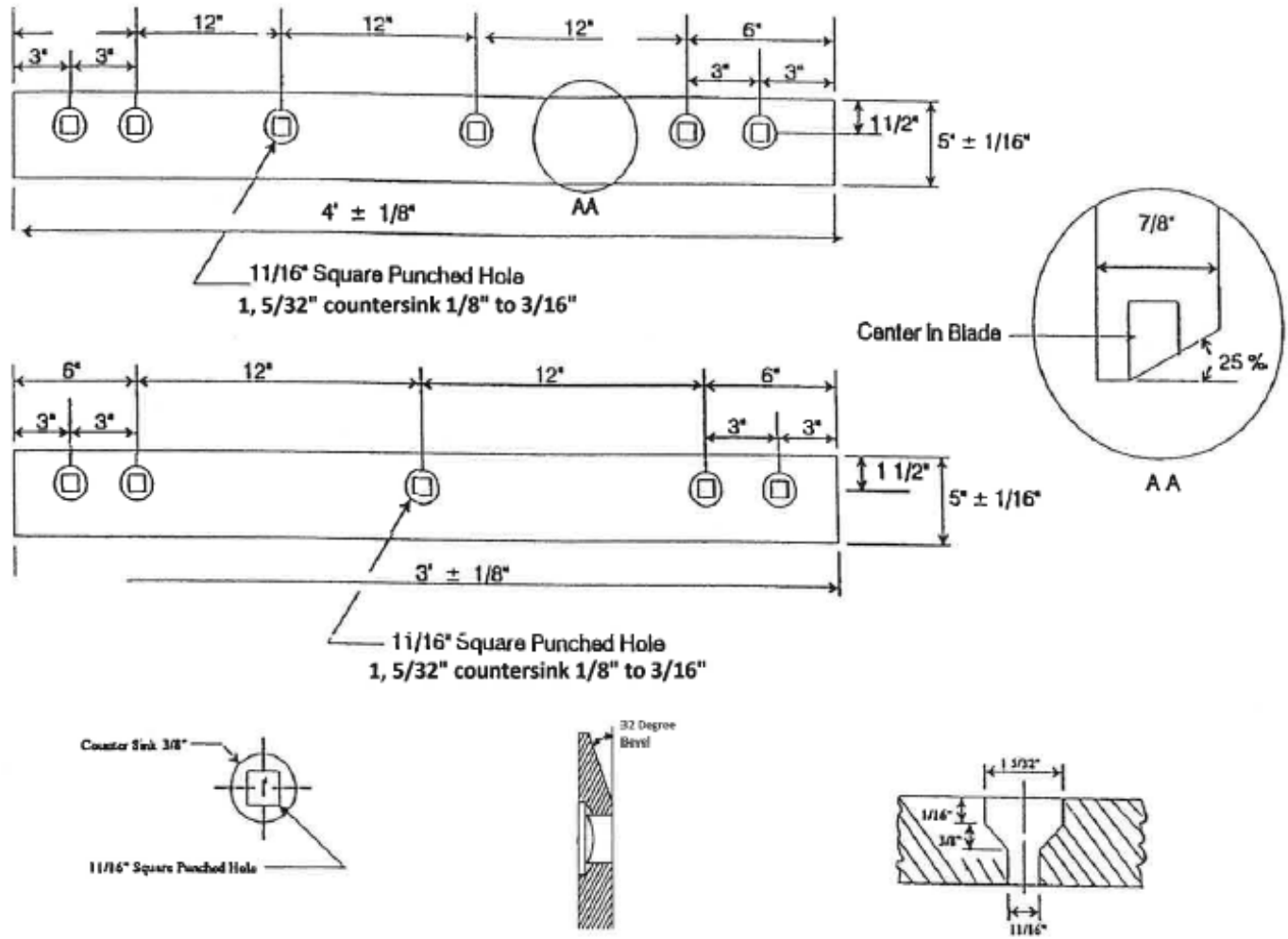

NOTE: This drawing not to scale.  
Follow Dimensions.

Plan of Carbide Tipped Underbody Scraper Blades