

DATE REVISED	DATE FILMED	DATE REVISED	DATE FILMED	FED. RD. DIST. NO.	STATE	FED. AID PROJ. NO.	SHEET NO.	TOTAL SHEETS
				6	ARK.			
				JOB NO.		012196	I	88
JONESBORO - I-55 (SEL. SECS.) (CABLE MEDIAN BARRIER) (S)								

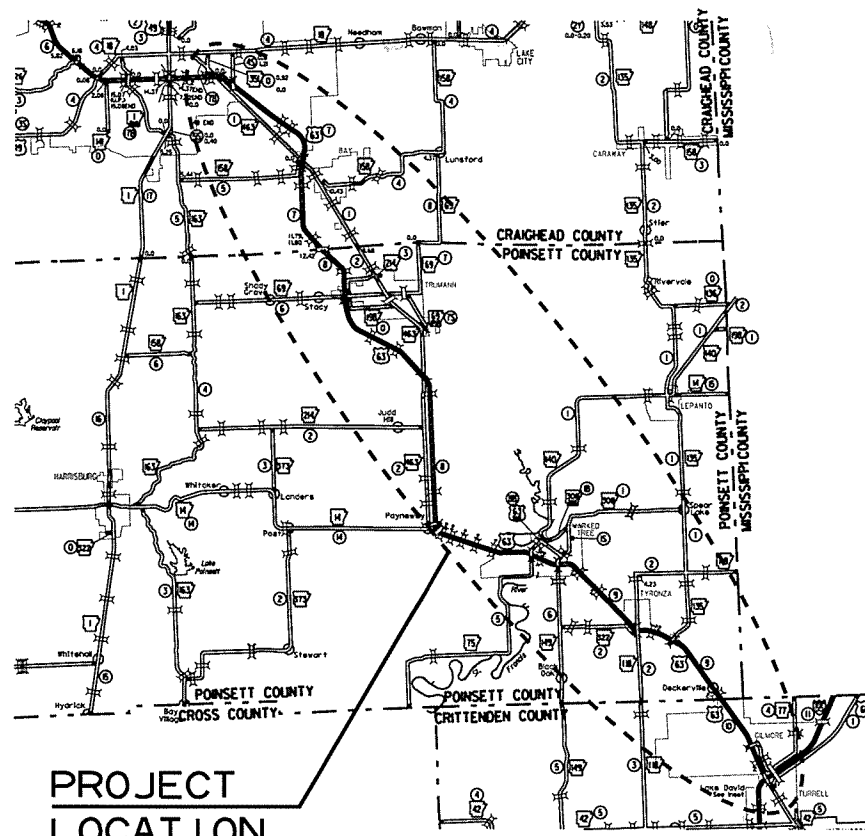

"A FULLY CONTROLLED ACCESS FACILITY"
 ARKANSAS STATE HIGHWAY AND TRANSPORTATION DEPARTMENT
 CONSTRUCTION PLANS FOR STATE HIGHWAY

JONESBORO - I-55 (SEL. SECS.) (CABLE MEDIAN BARRIER) (S)

CRAIGHEAD, POINSETT & CRITTENDEN COUNTIES
 ROUTE 63 SECTIONS 7, 8, 9 & 10

JOB 012196

FED. AID HSIP-0076(98)

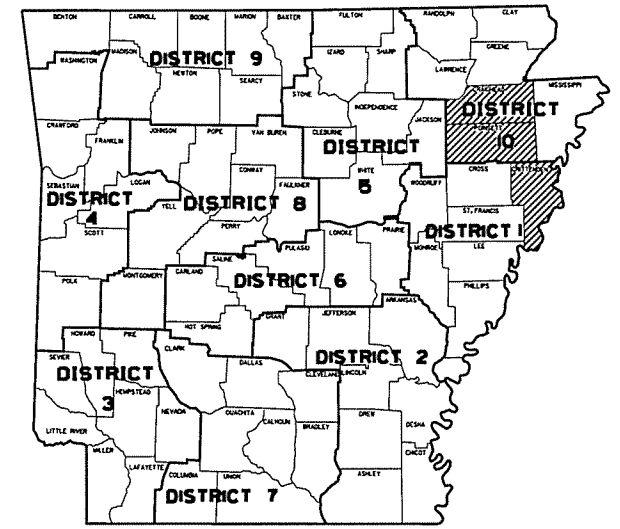

ARK. HWY. DIST. NO. 1 & 10

PROJECT LOCATION

VICINITY MAP

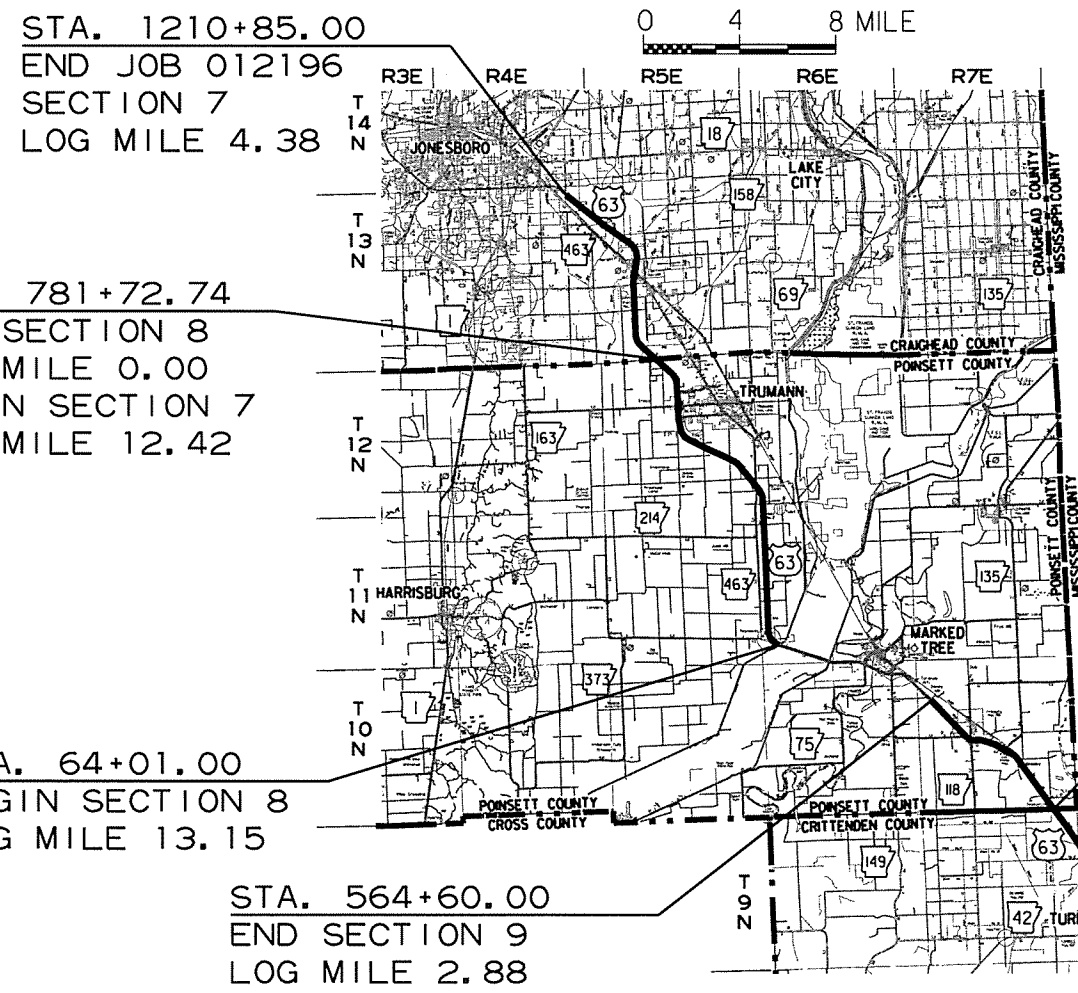

STA. 1210+85.00
 END JOB 012196
 SECTION 7
 LOG MILE 4.38

STA. 781+72.74
 END SECTION 8
 LOG MILE 0.00
 BEGIN SECTION 7
 LOG MILE 12.42

STA. 64+01.00
 BEGIN SECTION 8
 LOG MILE 13.15

STA. 564+60.00
 END SECTION 9
 LOG MILE 2.88

STA. 195+96.43
 END SECTION 10
 LOG MILE 0.00
 BEGIN SECTION 9
 LOG MILE 9.86

STA. 122+25.00
 BEGIN JOB 012196
 SECTION 10
 LOG MILE 3.46

• DESIGN TRAFFIC DATA •

	SEC. 7	SEC. 8	SEC. 9	SEC. 10
DESIGN YEAR	2034	2034	2034	2034
2014 ADT	14,000	12,500	11,500	11,000
2034 ADT	19,500	17,500	16,000	14,000
2034 DHV	2,145	1,925	1,760	1,540
TRUCKS	16%	19%	22%	23%
DESIGN SPEED	70 MPH	70 MPH	70 MPH	70 MPH

LOG MILES

SECTION 7 4.38 TO 12.42 IN CRAIGHEAD & POINSETT COUNTIES
 SECTION 8 0.00 TO 13.28 IN POINSETT COUNTY
 SECTION 9 2.88 TO 9.86 IN POINSETT COUNTY
 SECTION 10 0.00 TO 3.46 IN CRITTENDEN COUNTY

EQUATIONS TO JOB 012196

STA. 153+24.02(BK.)	- STA. 44+19.02(AHD.)	=	333'
STA. 407+78.75(BK.)	- STA. 409+78.93(AHD.)	=	90'
STA. 461+00.00(BK.)	- STA. 458+75.27(AHD.)	=	296'
STA. 102+92.04(BK.)	- STA. 101+96.76(AHD.)	=	560'
STA. 483+00.28(BK.)	- STA. 495+54.55(AHD.)	=	489'
		=	90'
		=	148'
		=	137'
		=	90'
		=	90'
		=	90'
		=	196'
		=	587'
		=	90'
		=	90'
		=	90'
		=	525'
		=	90'
		=	481'
		=	489'
		=	41'
		=	90'

EXCEPTIONS TO JOB 012196

STA. 151+32	- STA. 45+60	=	333'
STA. 181+18	- STA. 182+08	=	90'
STA. 208+08	- STA. 211+04	=	296'
STA. 401+21	- STA. 406+81	=	560'
STA. 543+53	- STA. 548+42	=	489'
STA. 551+98	- STA. 552+88	=	90'
STA. 67+55	- STA. 69+03	=	148'
STA. 159+81	- STA. 161+18	=	137'
STA. 196+55	- STA. 197+45	=	90'
STA. 350+05	- STA. 350+95	=	90'
STA. 362+03	- STA. 363+99	=	196'
STA. 400+93	- STA. 406+80	=	587'
STA. 449+55	- STA. 450+45	=	90'
STA. 537+55	- STA. 538+45	=	90'
STA. 662+93	- STA. 668+18	=	525'
STA. 765+55	- STA. 766+45	=	90'
STA. 811+32	- STA. 816+13	=	481'
STA. 979+21	- STA. 984+10	=	489'
STA. 1086+07	- STA. 1086+48	=	41'
STA. 1112+55	- STA. 1113+45	=	90'

TOTAL EXCEPTIONS = 5002'

BEGINNING OF PROJECT	MID-POINT OF PROJECT	END OF PROJECT
LAT. = N 35°23' 38.0"	LAT. = N 35°37' 27.9"	LAT. = N 35°48' 04.9"
LONG. = W 90°16' 28.5"	LONG. = W 90°29' 48.0"	LONG. = W 90°37' 27.8"

GROSS LENGTH OF PROJECT	168689.56	FEET	OR	31.948	MILES
NET " " ROADWAY	163687.56	" "	" "	31.001	" "
NET " " BRIDGES	0.00	" "	" "	0.000	" "
NET " " PROJECT	163687.56	" "	" "	31.001	" "

P.E. 012196
 NON-PART.

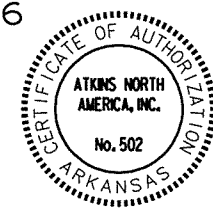

7/11/2014 11:02:07 AM P:\00038109\CA00\GEN\63TL01.dgn

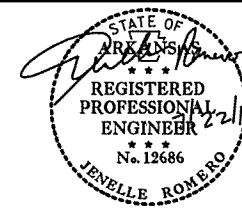

DATE REVISED	DATE FILMED	DATE REVISED	DATE FILMED	FED. RD. DIST. NO.	STATE	FED. AID PROJ. NO.	SHEET NO.	TOTAL SHEETS
				6	ARK.			
				JOB NO.		012196	2	88
INDEX, GOV. SPECS., AND GENERAL NOTES								

SHEET NO.	INDEX OF SHEETS TITLE	DRWG. NO.	DATE
1	TITLE SHEET		
2	INDEX OF SHEETS, GOVERNING SPECIFICATIONS, AND GENERAL NOTES		
3 - 4	TYPICAL SECTIONS OF IMPROVEMENT		
5 - 8	SPECIAL DETAILS		
9 - 38	TEMPORARY EROSION CONTROL DETAILS		
39 - 42	MAINTENANCE OF TRAFFIC		
43 - 46	QUANTITIES		
47	SUMMARY OF QUANTITIES AND REVISIONS		
48 - 77	PLAN SHEETS		
78	STANDARD DETAILS FOR TYPE 'PT' APPROACH GUTTERS (BRIDGES WITH CONCRETE PARAPET RAILING)	55035	2-27-14
79	CONCRETE DITCH PAVING	CDP-1	11-17-10
80	GUARD RAIL DETAILS	GR-8	7-14-10
81	GUARD RAIL DETAILS	GR-9A	4-17-08
82	GUARD RAIL DETAILS	GR-10	7-14-10
83	GUARD RAIL DETAILS	GRT-1	7-14-10
84	CONCRETE PIPE CULVERT FILL HEIGHTS & BEDDING	PCC-1	2-27-14
85	STANDARD TRAFFIC CONTROLS FOR HIGHWAY CONSTRUCTION	TC-1	12-15-11
86	STANDARD TRAFFIC CONTROLS FOR HIGHWAY CONSTRUCTION	TC-2	9-12-13
87	STANDARD TRAFFIC CONTROLS FOR HIGHWAY CONSTRUCTION	TC-3	10-15-09
87A	STANDARD TRAFFIC CONTROLS FOR HIGHWAY CONSTRUCTION - TEMPORARY PRECAST BARRIER	TC-4	2-27-14
87B	STANDARD TRAFFIC CONTROLS FOR HIGHWAY CONSTRUCTION - TEMPORARY PRECAST BARRIER	TC-5	10-15-09
88	TEMPORARY EROSION CONTROL DEVICES	TEC-1	12-15-11

GOVERNING SPECIFICATIONS

ARKANSAS STATE HIGHWAY COMMISSION STANDARD SPECIFICATIONS FOR HIGHWAY CONSTRUCTION, EDITION OF 2014, AND THE FOLLOWING SPECIAL PROVISIONS AND SUPPLEMENTAL SPECIFICATIONS:

NUMBER	TITLE
ERRATA	ERRATA FOR THE BOOK OF STANDARD SPECIFICATIONS
FHWA-1273	REQUIRED CONTRACT PROVISIONS FEDERAL-AID CONSTRUCTION CONTRACTS
FHWA-1273	SUPPLEMENT-EQUAL EMPLOYMENT OPPORTUNITY-NOTICE TO CONTRACTORS
FHWA-1273	SUPPLEMENT-SPECIFIC EQUAL EMPLOYMENT OPPORTUNITY RESPONSIBILITIES (23 U.S.C. 140)
FHWA-1273	SUPPLEMENT-EQUAL EMPLOYMENT OPPORTUNITY-GOALS AND TIMETABLES
FHWA-1273	SUPPLEMENT-EQUAL EMPLOYMENT OPPORTUNITY-FEDERAL STANDARDS
FHWA-1273	SUPPLEMENT-POSTERS AND NOTICES REQUIRED FOR FEDERAL AID PROJECTS
FHWA-1273	SUPPLEMENT-WAGE RATE DETERMINATION
108-1	LIQUIDATED DAMAGES
410-1	CONSTRUCTION REQUIREMENTS AND ACCEPTANCE OF ASPHALT CONCRETE PLANT MIX COURSES
620-1	MULCH COVER
JOB 012196	BROADBAND INTERNET SERVICE FOR ASPHALT CONCRETE PLANT
JOB 012196	CONCRETE DITCH PAVING
JOB 012196	GOALS FOR DISADVANTAGED BUSINESS ENTERPRISE PARTICIPATION
JOB 012196	MAINTENANCE OF TRAFFIC
JOB 012196	MANDATORY USE OF INTERNET BIDDING
JOB 012196	PARTNERING REQUIREMENTS
JOB 012196	REMOVAL AND DISPOSAL OF IMPACT ATTENUATION BARRIERS
JOB 012196	SEQUENCE OF CONSTRUCTION
JOB 012196	SITE USE (A+C METHOD)
JOB 012196	STORM WATER POLLUTION PREVENTION PLAN
JOB 012196	SUBMISSION OF ASPHALT CONCRETE HOT MIX ACCEPTANCE TEST RESULTS
JOB 012196	TRAFFIC CONTROL DEVICES IN CONSTRUCTION ZONES
JOB 012196	UTILITY ADJUSTMENTS
JOB 012196	VALUE ENGINEERING
JOB 012196	WARM MIX ASPHALT
JOB 012196	WIRE ROPE SAFETY FENCE MAINTENANCE MATERIALS
JOB 012196	WIRE ROPE SAFETY FENCE (WRSF) SPECIFICATIONS
JOB 012196	WIRE ROPE SAFETY FENCE (POST REPAIR)
JOB 012196	WRSF TRAINING WORKSHOP

GENERAL NOTES

- ALL PIPE LINES, POWER, TELEPHONE, AND TELEGRAPH LINES TO BE MOVED OR LOWERED BY THE RESPECTIVE OWNERS AS PER AGREEMENT WITH SUCH OWNERS.
- ANY EQUIPMENT OR APPURTENANCE THAT INTERFERES WITH THE PROPOSED CONSTRUCTION AND WHICH MAY BE THE PROPERTY OF UTILITY SERVICE ORGANIZATIONS SHALL BE MOVED BY THE OWNERS UNLESS OTHERWISE PROVIDED.
- ALL LAND MONUMENTS LOCATED WITHIN THE CONSTRUCTION AREA SHALL BE PROTECTED IN ACCORDANCE WITH SECTION 107.12 OF THE STANDARD SPECIFICATIONS.
- ALL FLEXIBLE BASE AND ASPHALTIC PAVEMENTS REMOVED SHALL BE PAID FOR UNDER THE ITEM NO.210 - UNCLASSIFIED EXCAVATION.
- THE EXISTING ASPHALT PAVEMENT TO BE REMOVED FROM THE REMAINING PAVEMENT SHALL BE SEPARATED BY SAWING ALONG A NEAT LINE. AFTER SAWING, THE PAVEMENT TO BE REMOVED SHALL BE CAREFULLY REMOVED IN A MANNER THAT WILL NOT DAMAGE THE PAVEMENT THAT IS TO REMAIN. ANY DAMAGE OF THE ASPHALT PAVEMENT THAT IS TO REMAIN IN PLACE SHALL BE REPAIRED AT THE CONTRACTOR'S EXPENSE.
- WASTE MATERIAL SHALL BE DISPOSED OF AS APPROVED BY THE ENGINEER.
- CONTRACTOR TO ADJUST POSTS IN THE FIELD SO THAT EXISTING DRAINAGE STRUCTURES ARE AVOIDED.

INDEX OF SHEETS, GOVERNING SPECIFICATIONS, AND GENERAL NOTES

7/21/2014 3:40:30 PM P:\100038109\CA00\GEN\3\index.dgn

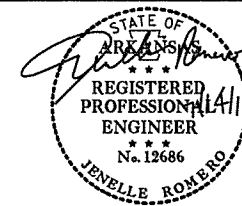

DATE REVISED	DATE FILMED	DATE REVISED	DATE FILMED	FED. RD. DIST. NO.	STATE	FED. AID PROJ. NO.	SHEET NO.	TOTAL SHEETS
				6	ARK.			
JOB NO. 02196							3	88

TYPICAL SECTIONS OF IMPROVEMENT

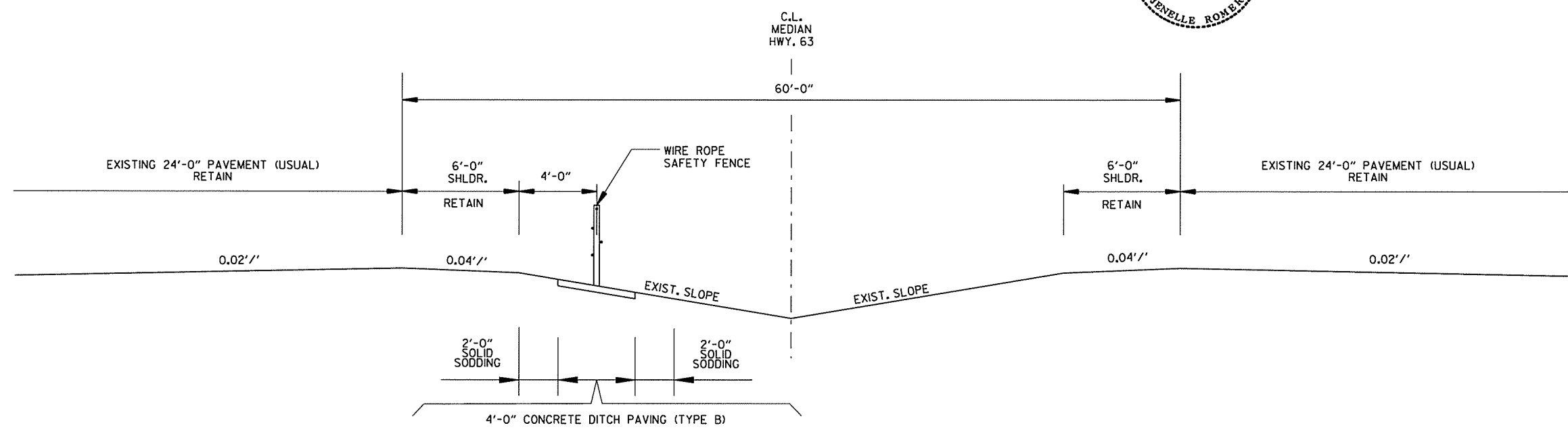

TYPICAL SECTION OF IMPROVEMENT
WIRE ROPE SAFETY FENCE ON SOUTHBOUND LANES FORESLOPE

SECTIONS 9 & 10
STA. 182+08.00 TO STA. 357+26.00
STA. 406+81.00 TO STA. 435+58.00
STA. 552+88.00 TO STA. 564+60.00
STA. 1170+65.00 TO STA. 1210+85.00

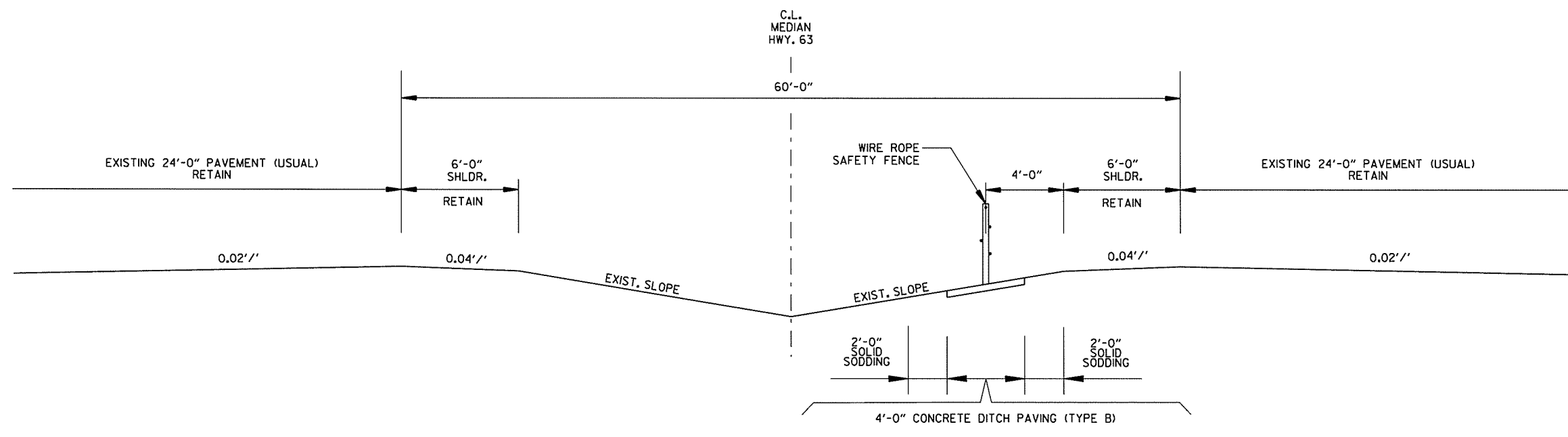

TYPICAL SECTION OF IMPROVEMENT
WIRE ROPE SAFETY FENCE ON NORTHBOUND LANES FORESLOPE

SECTIONS 9 & 10
STA. 122+25.00 TO STA. 181+18.00
STA. 359+33.00 TO STA. 401+21.00
STA. 437+99.00 TO STA. 551+98.00

TYPICAL SECTIONS OF IMPROVEMENT

7/11/2014 11:02:11 AM P:\00038109\CAADD\PAV\63\Typ.dgn

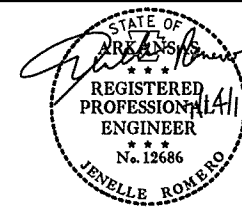

DATE REVISED	DATE FILMED	DATE REVISED	DATE FILMED	FED. RD. DIST. NO.	STATE	FED. AID PROJ. NO.	SHEET NO.	TOTAL SHEETS
				6	ARK.			
				JOB NO.	012196		4	88

TYPICAL SECTIONS OF IMPROVEMENT

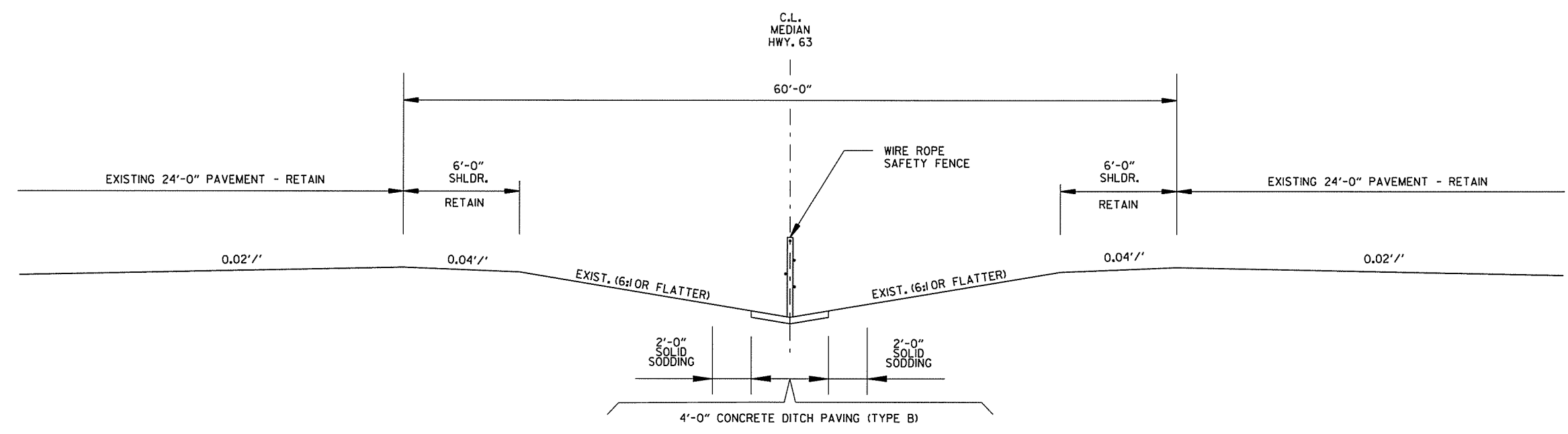

PROPOSED TYPICAL SECTION
 WRSF IN BOTTOM OF DITCH
 SECTIONS 7 & 8
 STA. 70+65.00 TO STA. 1171+15.00

TYPICAL SECTIONS OF IMPROVEMENT

7/11/2014 11:02:12 AM P:\00038109\CADD\PAV\631Typ.dgn

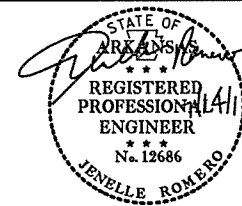

DATE REVISED	DATE FILMED	DATE REVISED	DATE FILMED	FED. RD. DIST. NO.	STATE	FED. AID PROJ. NO.	SHEET NO.	TOTAL SHEETS
				6	ARK.			
JOB NO. 02196							5	88

SPECIAL DETAILS

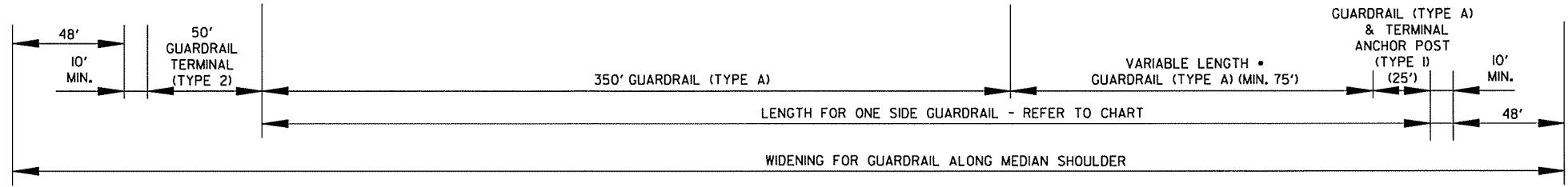
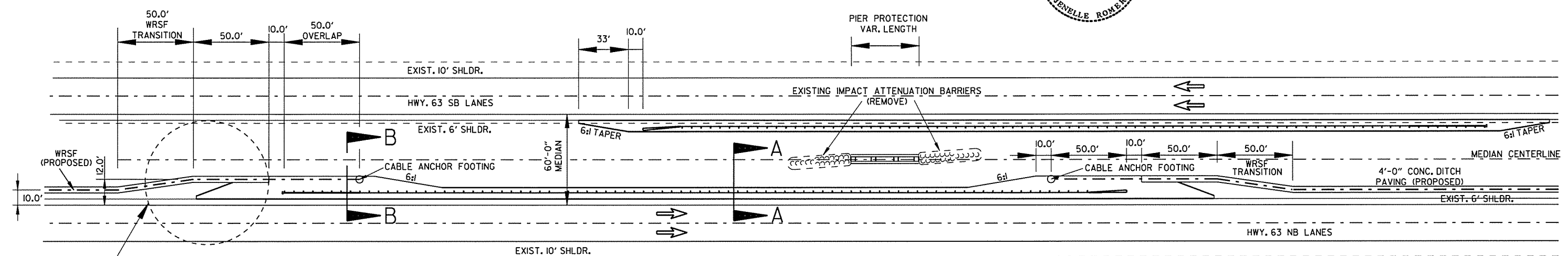

SECTIONS 9 & 10			
STATION	CROSSING ROAD NAME	PIER PROTECTION LENGTH	LENGTH FOR ONE SIDE GUARDRAIL
81+05	HWY. 77	43.0'	525'
358+29	HWY. 135	43.0'	525'
436+77	HWY. 118	55'	550'

• GUARDRAIL LENGTH IS ROUNDED UP BASED ON GUARDRAIL STOCK LENGTH OF 25.0'.

DETAIL AT OVERPASSES

WRSF ON FORESLOPE

NOTE: REFER TO PLAN SHEETS FOR PLACEMENT OF WIRE ROPE SAFETY FENCE ON NORTHBOUND OR SOUTHBOUND FORESLOPES.

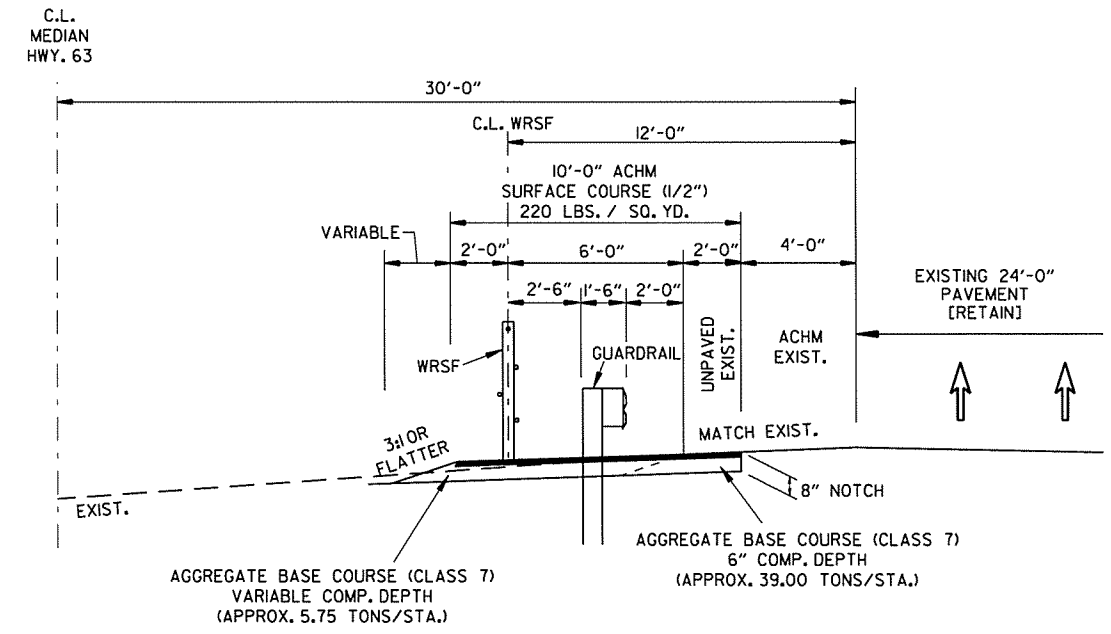
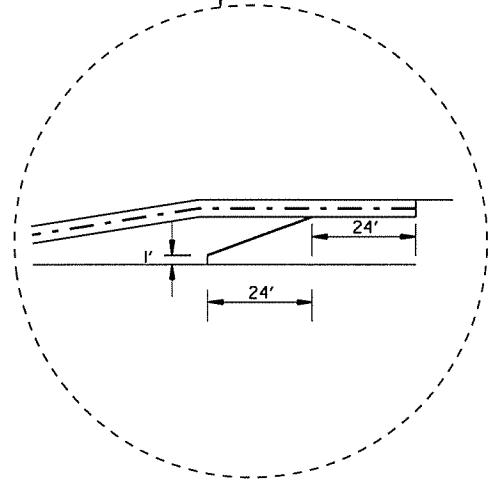

SECTION B-B

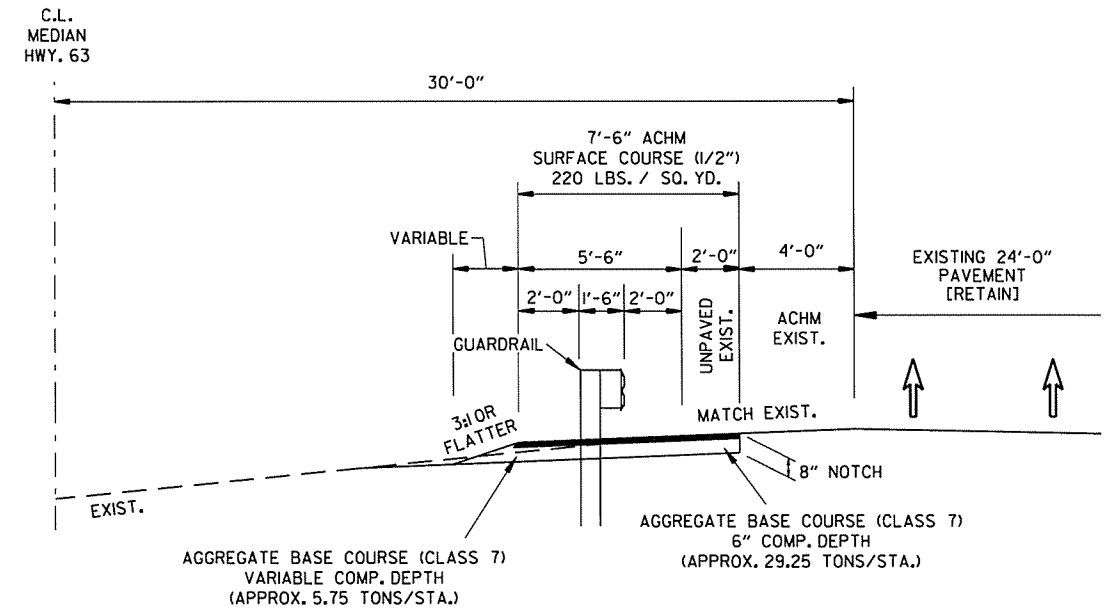

SECTION A-A

SPECIAL DETAILS

7/17/2014 11:02:12 AM P:\00038109\CA00\GEN\63\WRSF_details.dgn

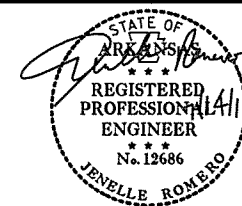

DATE REVISED	DATE FILMED	DATE REVISED	DATE FILMED	FED. RD. DIST. NO.	STATE	FED. AID PROJ. NO.	SHEET NO.	TOTAL SHEETS
				6	ARK.			
						JOB NO. 02196	6	88

SPECIAL DETAILS

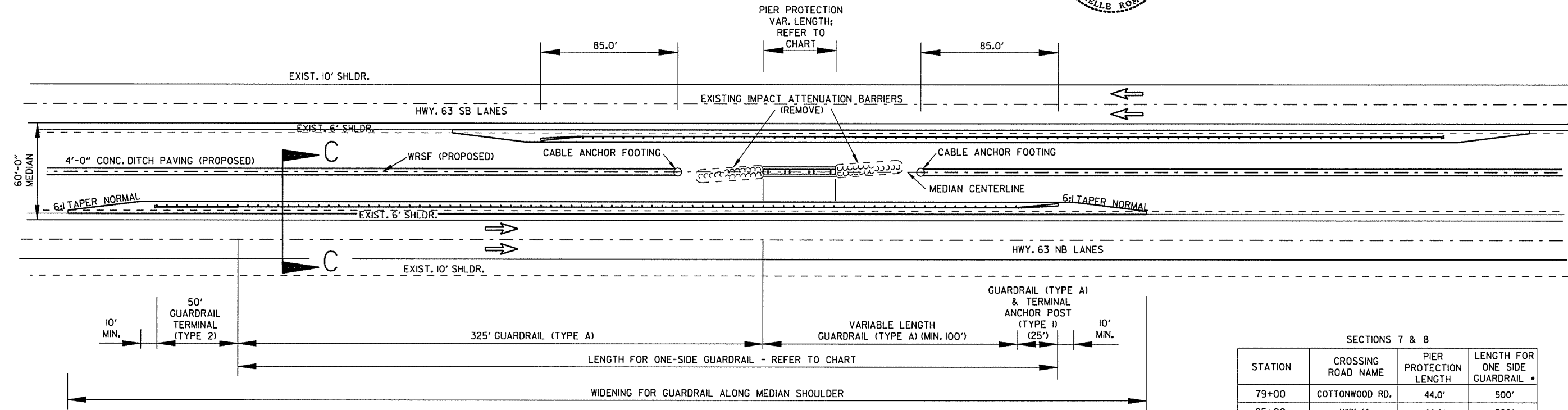

DETAIL AT OVERPASSES WRSF ON CL MEDIAN

DIMENSIONS ARE TYPICAL BOTH DIRECTIONS

SECTIONS 7 & 8

STATION	CROSSING ROAD NAME	PIER PROTECTION LENGTH	LENGTH FOR ONE SIDE GUARDRAIL *
79+00	COTTONWOOD RD.	44.0'	500'
95+00	HWY. 14	44.0'	500'
495+64	CO. RD. 231	28.0'	500'
555+72	CO. RD. 230	28.0'	500'
780+64	CO. RD. 652	28.0'	500'
926+39	CO. RD. 638	28.0'	500'
1061+41	GUM POINT RD.	28.0'	500'

* GUARDRAIL LENGTH IS ROUNDED UP BASED ON GUARDRAIL STOCK LENGTH OF 25.0'.

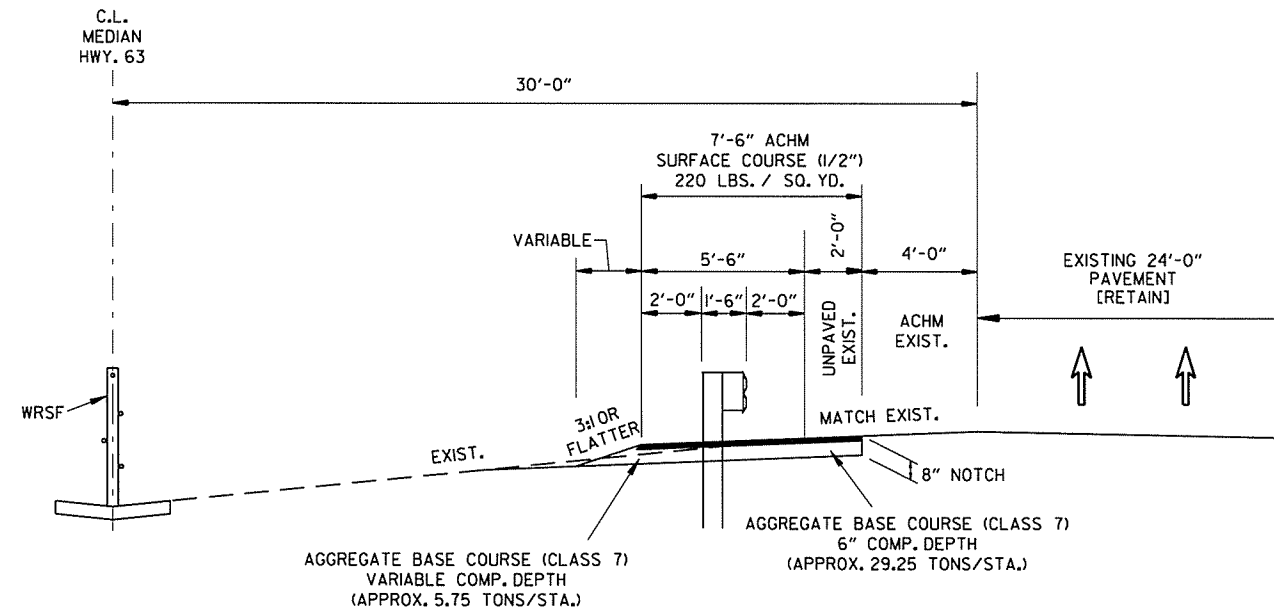

SECTION C-C

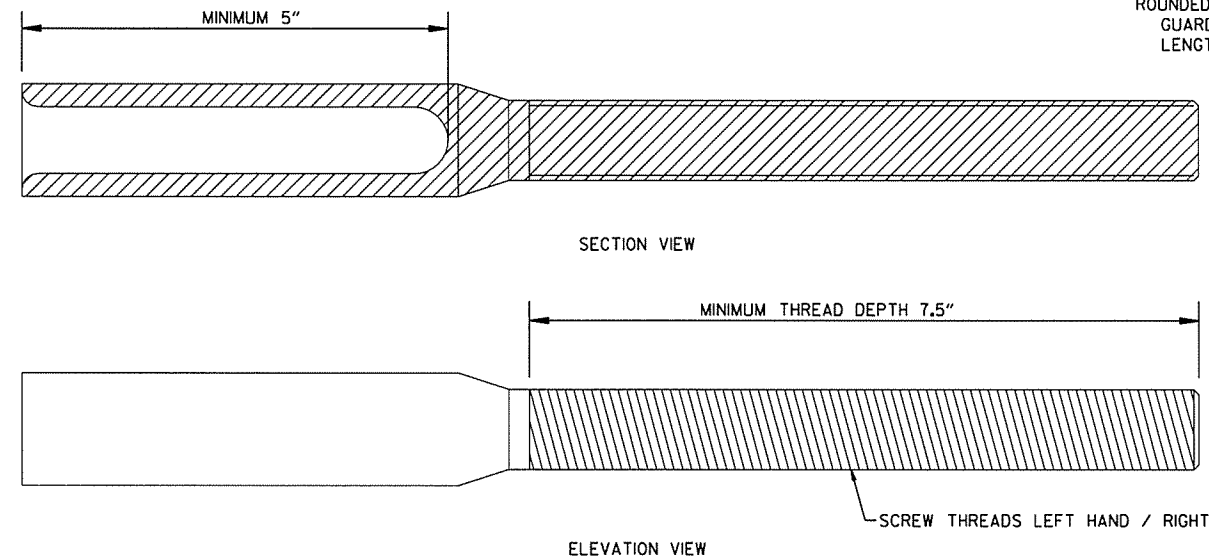

THREADED TERMINAL DETAIL

NOTE:
REFER TO "WIRE ROPE SAFETY FENCE (WRSF) SPECIFICATIONS" SPECIAL PROVISION FOR ADDITIONAL REQUIREMENTS.

7/17/2014 11:02:13 AM P:\100038103\CADD\GEN\63\WRSF_detailed.dgn

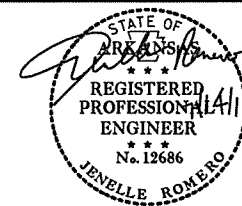

DATE REVISED	DATE FILMED	DATE REVISED	DATE FILMED	FED. RD. DIST. NO.	STATE	FED. AID PROJ. NO.	SHEET NO.	TOTAL SHEETS
				6	ARK.			
				JOB NO.		012196	7	88

SPECIAL DETAILS

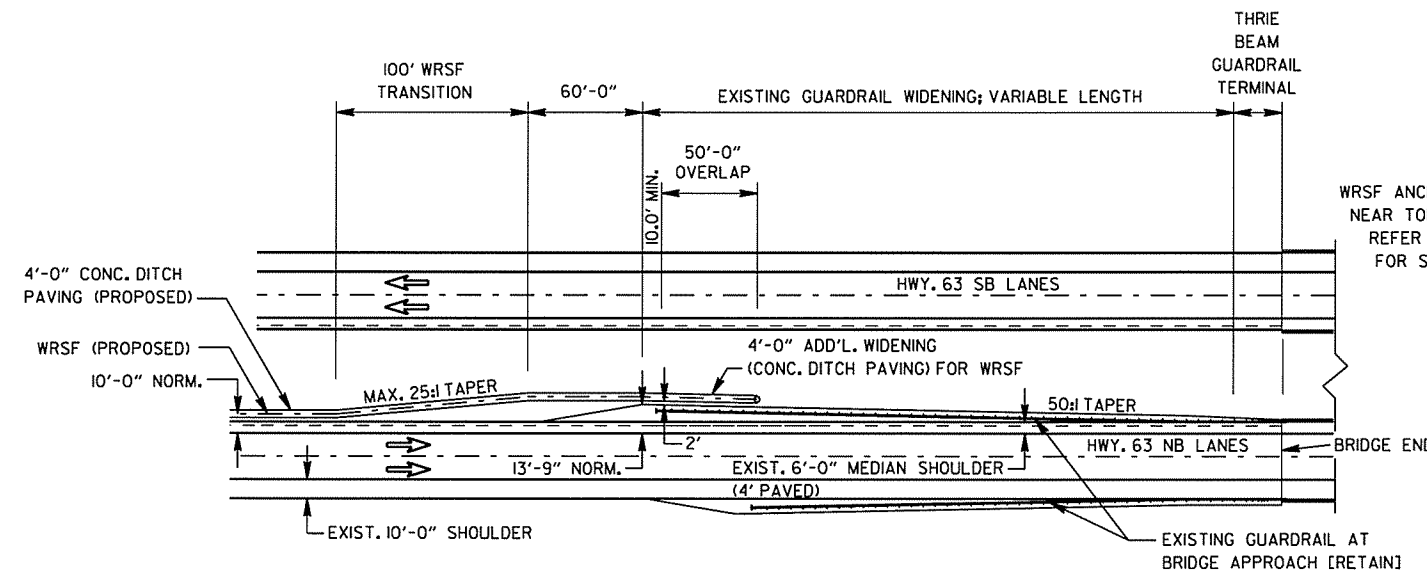

WRSF AND EXIST. GUARDRAIL ON SAME SIDE OF MEDIAN

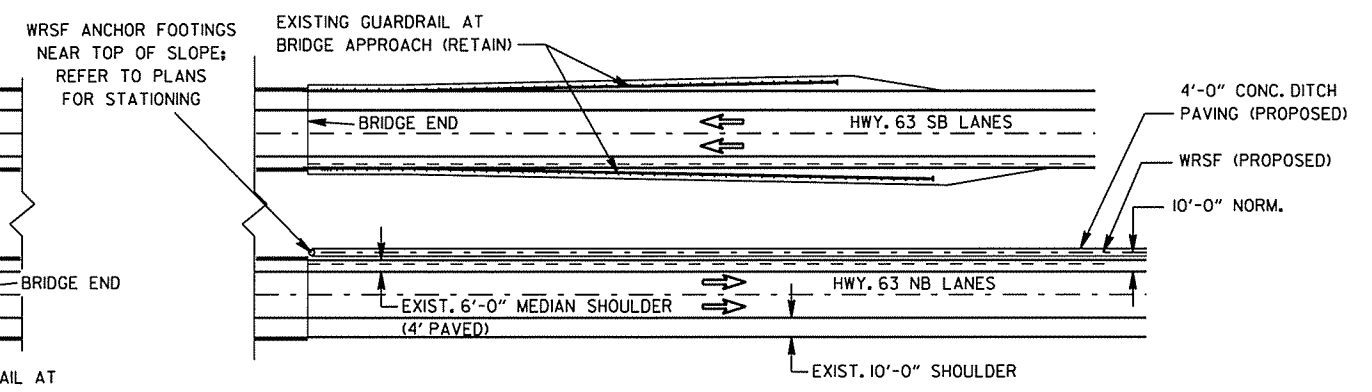

WRSF AND EXIST. GUARDRAIL ON OPPOSITE SIDES OF MEDIAN

DETAIL OF WIRE ROPE SAFETY FENCE AT EXISTING BRIDGE ENDS
WRSF ON FORESLOPE

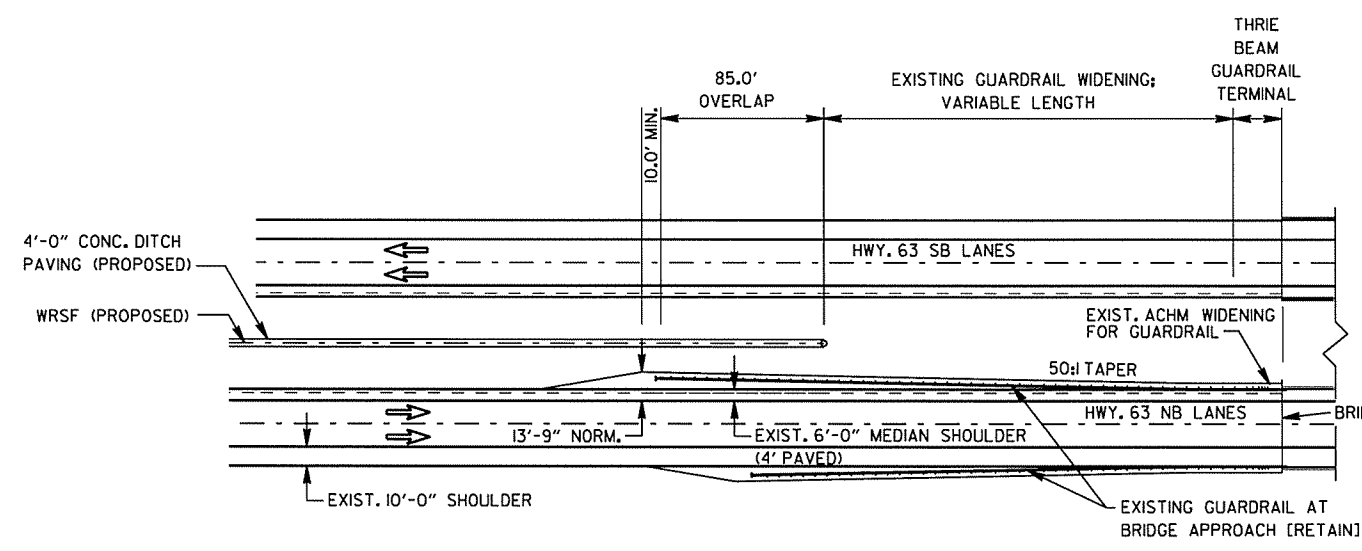

DETAIL OF WIRE ROPE SAFETY FENCE AT EXISTING BRIDGE ENDS
WRSF IN CL MEDIAN

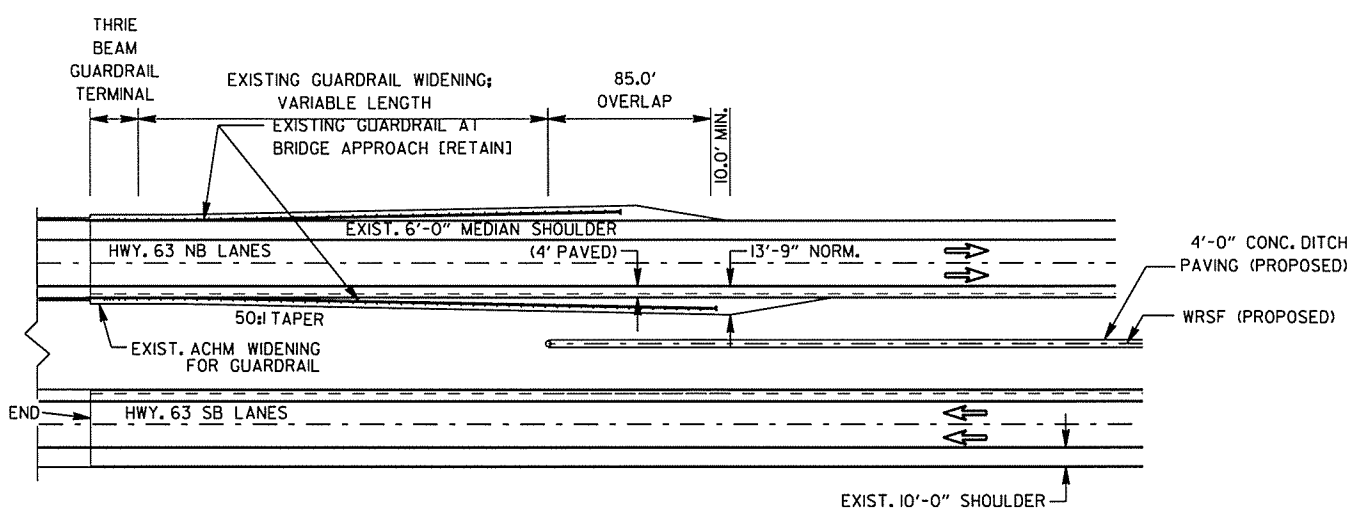

SPECIAL DETAILS

7/11/2014 11:02:13 AM P:\100038109\CADD\GEN\63WRSF_details.dgn

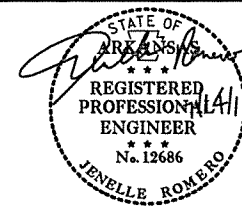

DATE REVISED	DATE FILMED	DATE REVISED	DATE FILMED	FED. RD. DIST. NO.	STATE	FED. AID PROJ. NO.	SHEET NO.	TOTAL SHEETS
				6	ARK.			
				JOB NO.	012196	8	88	

SPECIAL DETAILS

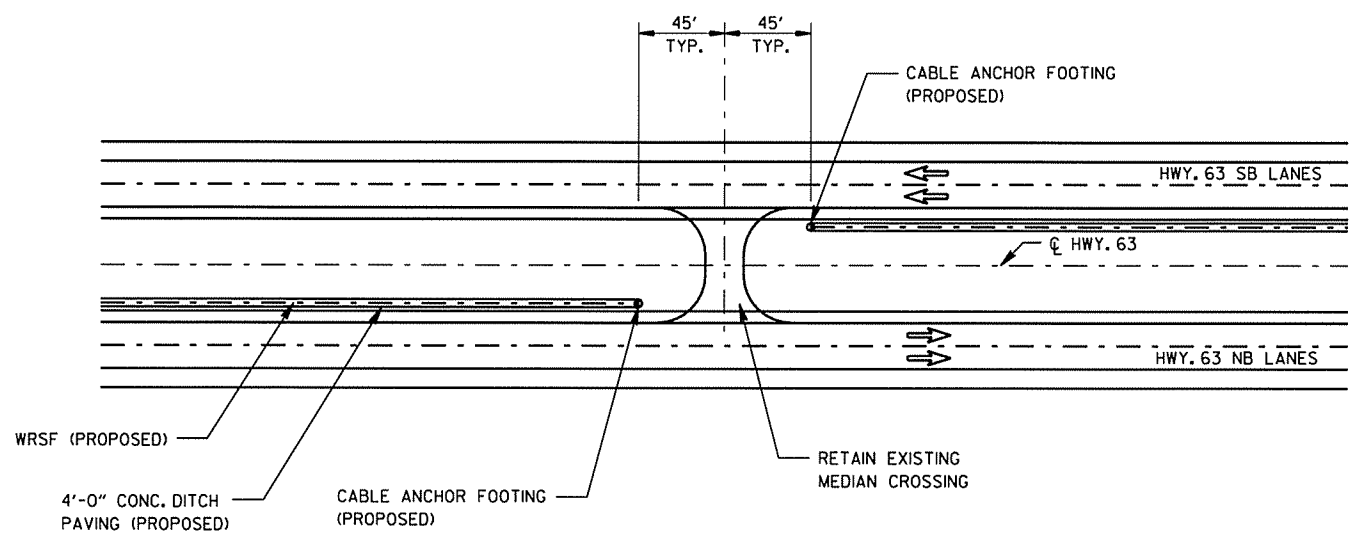

DETAIL AT MEDIAN CROSSING
WRSF ON FORESLOPE

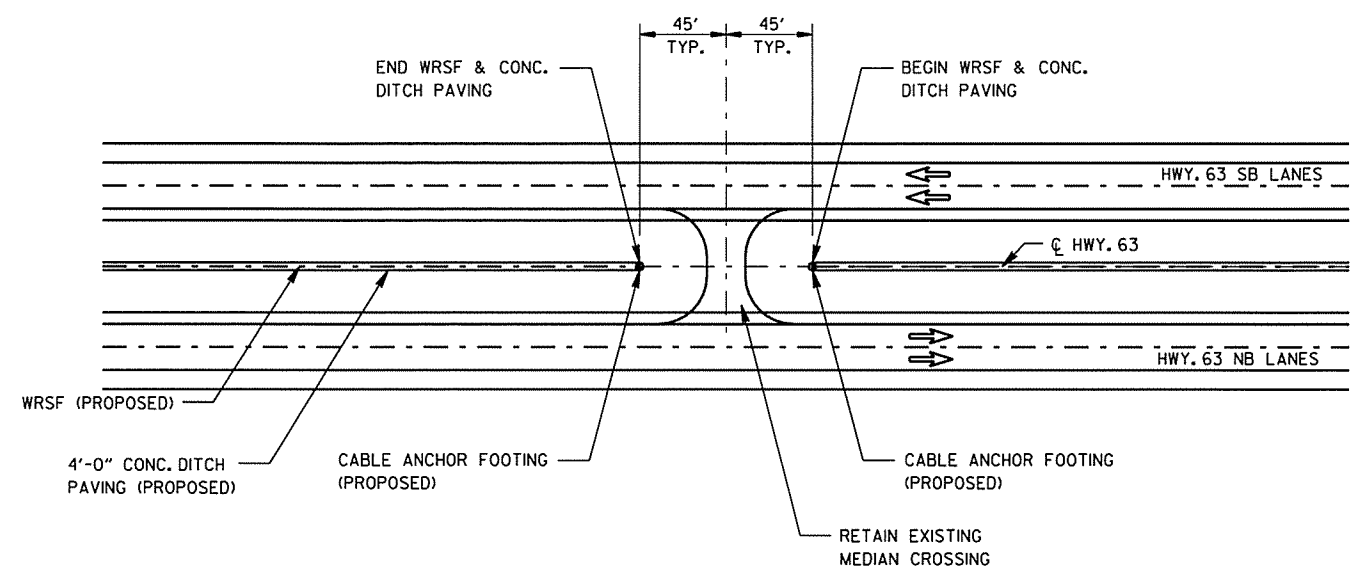

DETAIL AT MEDIAN CROSSING
WRSF IN CL MEDIAN

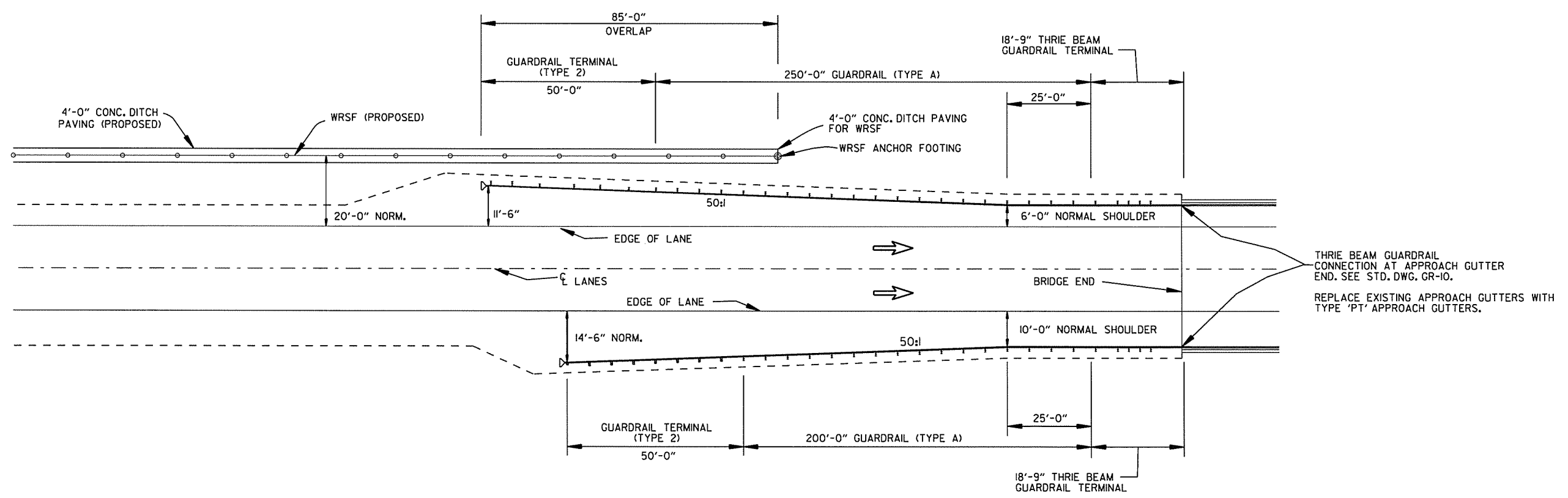

DETAIL OF WIRE ROPE SAFETY FENCE AND
TYPICAL LAYOUT OF PROPOSED GUARDRAIL AT BRIDGE ENDS

SPECIAL DETAILS

7/17/2014 11:02:13 AM P:\100038109\CAADD\GEN\63WRSF_details.dgn



DATE REVISED	DATE FILMED	DATE REVISED	DATE FILMED	FED. RD. DIST. NO.	STATE	FED. AID PROJ. NO.	SHEET NO.	TOTAL SHEETS
				6	ARK.	012196	9	88
				JOB NO. 012196				

TEMPORARY EROSION CONTROL DETAILS

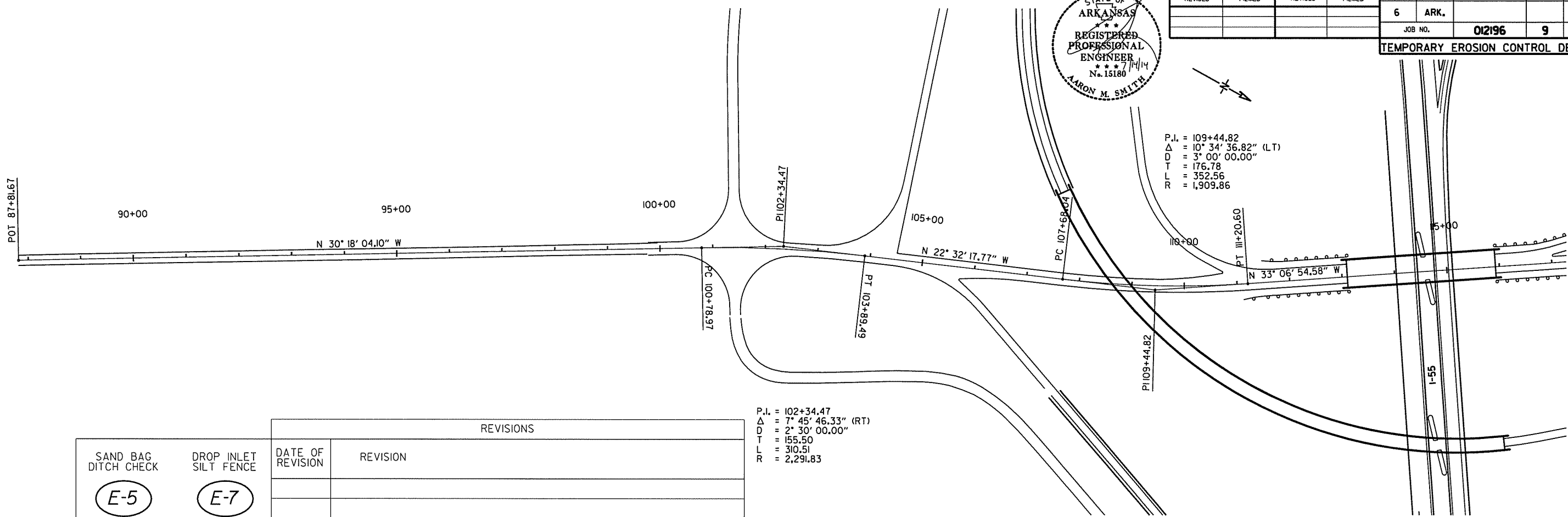

LEGEND		REVISIONS	
SAND BAG DITCH CHECK E-5 	DROP INLET SILT FENCE E-7 □	DATE OF REVISION	REVISION

P.I. = 102+34.47
 Δ = 7° 45' 46.33" (RT)
 D = 2° 30' 00.00"
 T = 155.50
 L = 310.51
 R = 2,291.83

INDICATES DIRECTION OF MEDIAN DRAINAGE

STA. 122+25.00
 BEGIN JOB 012196
 SECTION 10
 BEGIN WRSF
 ON NB FORESLOPE
 LOG MILE 3.46

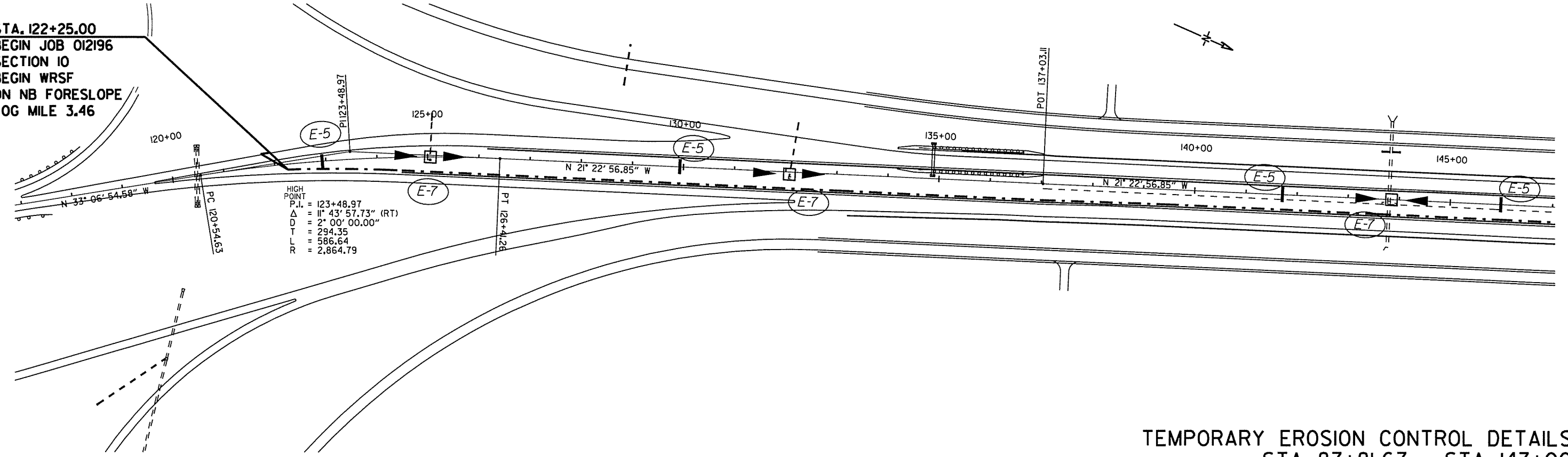

TEMPORARY EROSION CONTROL DETAILS
 STA. 87+81.67 - STA. 147+00

7/11/2014 11:02:14 AM P:\00038109\CADD\CEI\SHEETS\HWY 63\HWY63_EC-1.dgn



DATE REVISED	DATE FILMED	DATE REVISED	DATE FILMED	FED. RD. DIST. NO.	STATE	FED. AID PROJ. NO.	SHEET NO.	TOTAL SHEETS
				6	ARK.			
JOB NO. 012196							10	88

TEMPORARY EROSION CONTROL DETAILS

EQUATION:
STA. 153+24.02 BK =
STA. 44+19.02 AHD

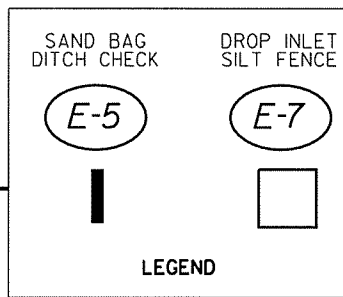
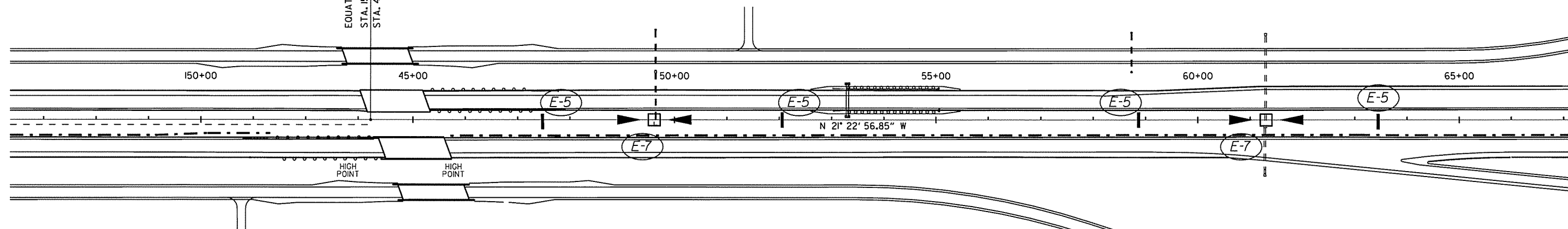

REVISIONS	
DATE OF REVISION	REVISION

INDICATES DIRECTION OF MEDIAN DRAINAGE

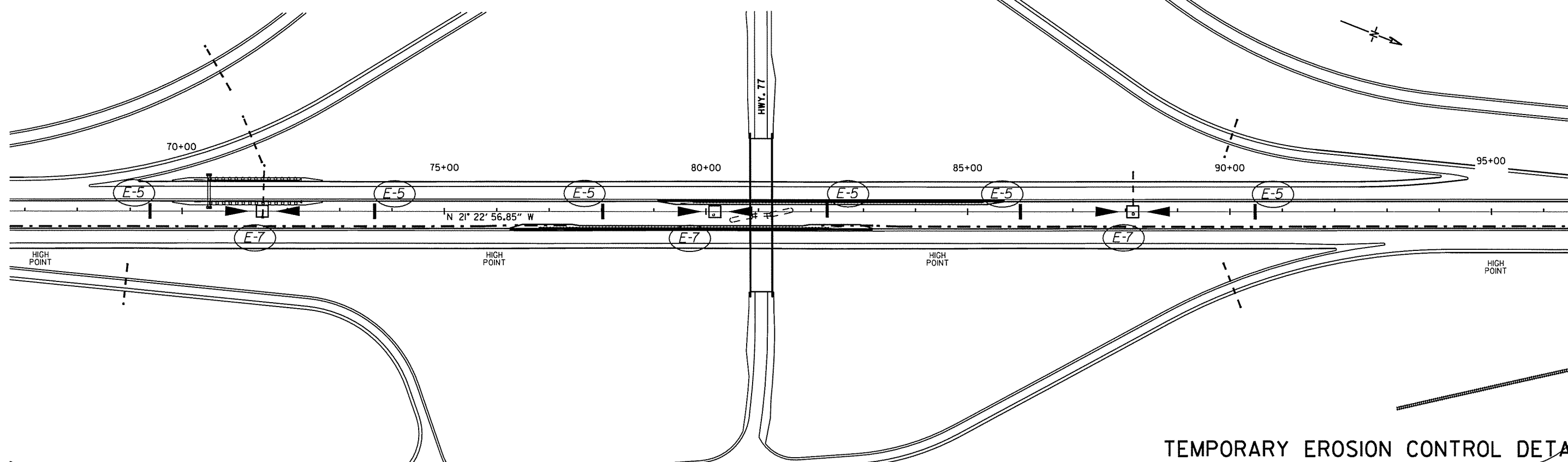

TEMPORARY EROSION CONTROL DETAILS
STA. 147+00 - STA. 96+00

7/17/2014 11:02:14 AM P:\00038109\CADD\SHEETS\HWY 63\HWY63_EC-2.dgn



DATE REVISED	DATE FILMED	DATE REVISED	DATE FILMED	FED. RD. DIST. NO.	STATE	FED. AID PROJ. NO.	SHEET NO.	TOTAL SHEETS
				6	ARK.		II	88
				JOB NO.		012196		
TEMPORARY EROSION CONTROL DETAILS								

P.I. = 102+63.67
 Δ = 12° 40' 00.00" (LT)
 D = 1' 40' 34.44"
 T = 379.38
 L = 755.66
 R = 3,418.13

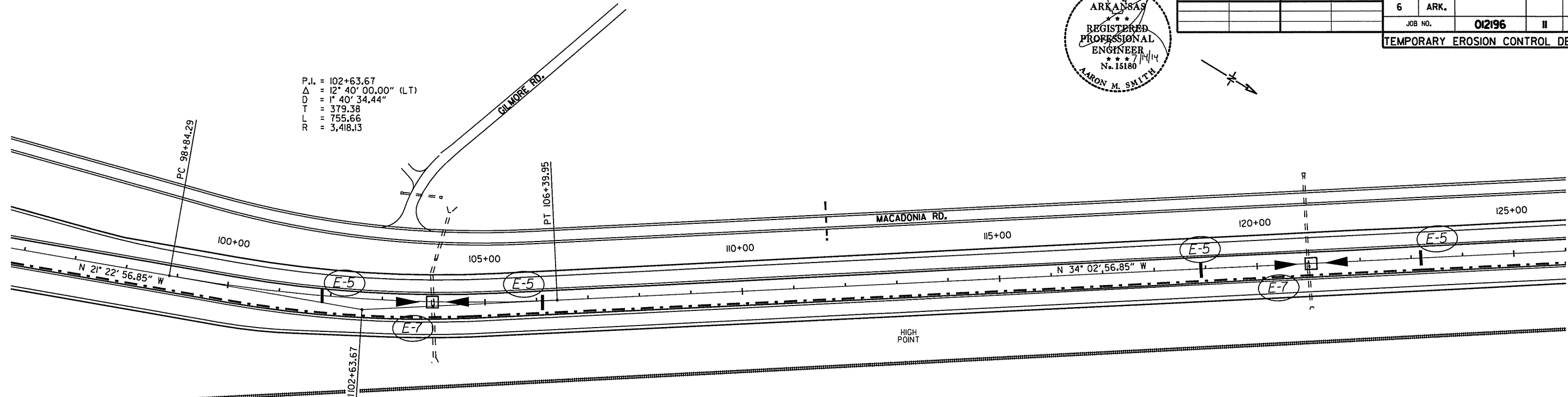

N. BENTON MOORE RD.

SAND BAG DITCH CHECK

E-5

DROP INLET SILT FENCE

E-7

REVISIONS

DATE OF REVISION	REVISION

INDICATES DIRECTION OF MEDIAN DRAINAGE

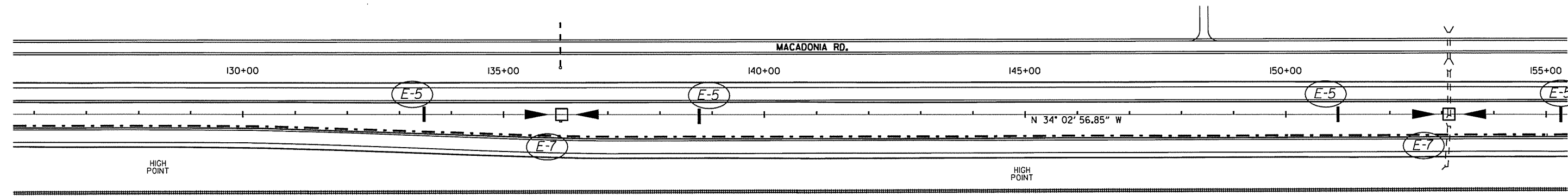

TEMPORARY EROSION CONTROL DETAILS
 STA. 96+00 - STA. 155+00

P:\100038109\CADD\CSHETS\HWY 63\HWY63_EC-3.dgn 7/17/2014 AM 11:02:14 AM



DATE REVISED	DATE FILMED	DATE REVISED	DATE FILMED	FED. RD. DIST. NO.	STATE	FED. AID PROJ. NO.	SHEET NO.	TOTAL SHEETS
				6	ARK.			
				JOB NO.	012196	12	88	

TEMPORARY EROSION CONTROL DETAILS

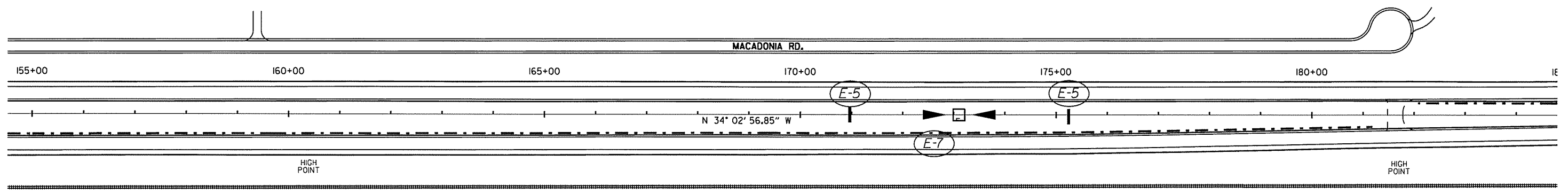

LEGEND		REVISIONS	
SAND BAG DITCH CHECK E-5 	DROP INLET SILT FENCE E-7 □	DATE OF REVISION	REVISION

INDICATES DIRECTION OF MEDIAN DRAINAGE

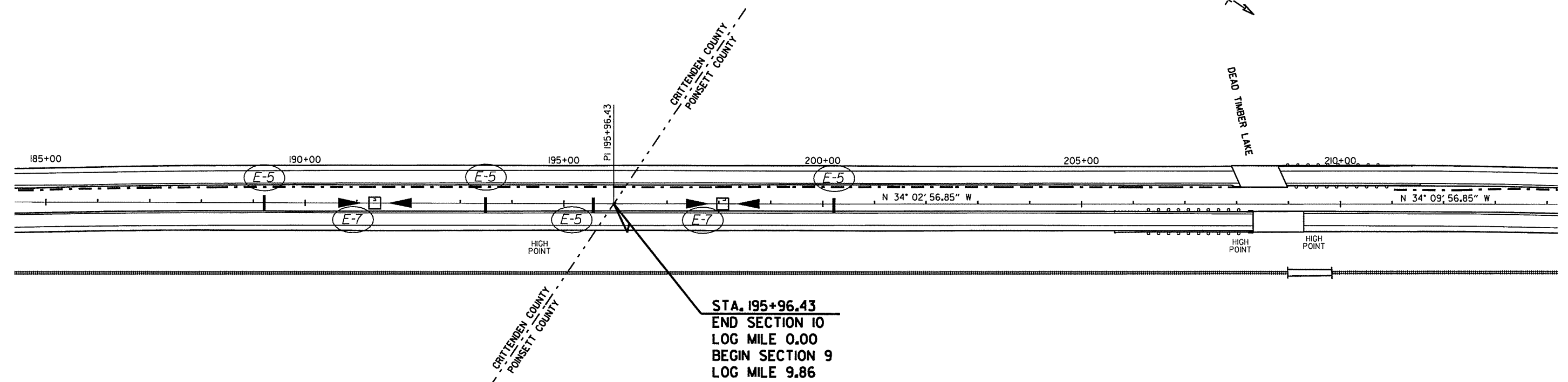

STA. 195+96.43
END SECTION 10
LOG MILE 0.00
BEGIN SECTION 9
LOG MILE 9.86

TEMPORARY EROSION CONTROL DETAILS
STA. 155+00 - STA. 214+00

7/17/2014 11:02:15 AM P:\00038109\CADD\SHETS\HWY 63\HWY63 EC-4.dgn



DATE REVISED	DATE FILMED	DATE REVISED	DATE FILMED	FED. RD. DIST. NO.	STATE	FED. AID PROJ. NO.	SHEET NO.	TOTAL SHEETS	
				6	ARK.				
JOB NO.							012196	13	88

TEMPORARY EROSION CONTROL DETAILS

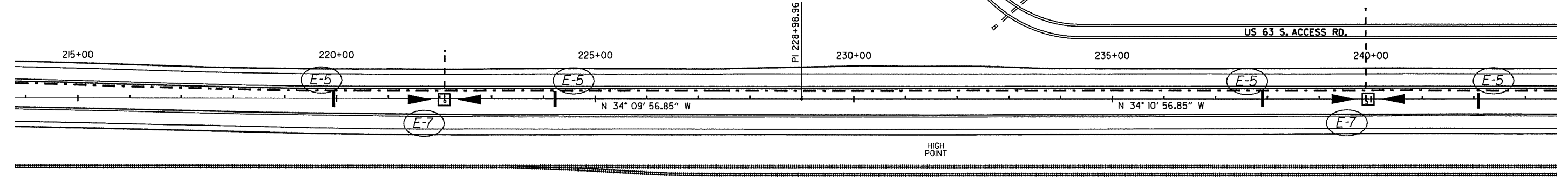

		REVISIONS	
SAND BAG DITCH CHECK	DROP INLET SILT FENCE	DATE OF REVISION	REVISION

INDICATES DIRECTION OF MEDIAN DRAINAGE

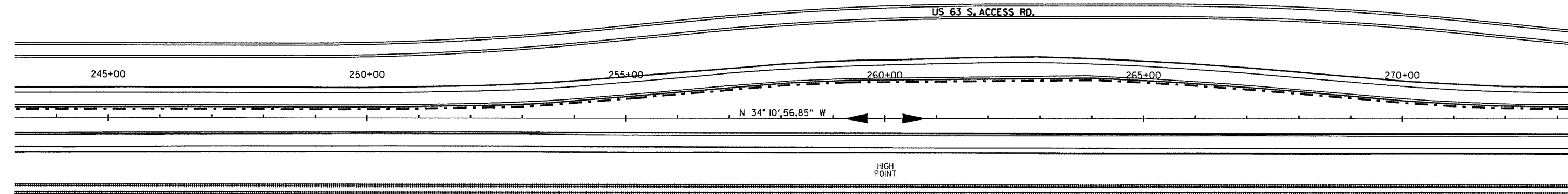

TEMPORARY EROSION CONTROL DETAILS
STA. 214+00 - STA. 273+00

7/17/2014 11:02:16 AM P:\00038109\CADD\SHEETS\HWY 63\HWY63 EC-5.dgn



DATE REVISED	DATE FILMED	DATE REVISED	DATE FILMED	FED. RD. DIST. NO.	STATE	FED. AID PROJ. NO.	SHEET NO.	TOTAL SHEETS
				6	ARK.			
				JOB NO.		012196	14	88

TEMPORARY EROSION CONTROL DETAILS

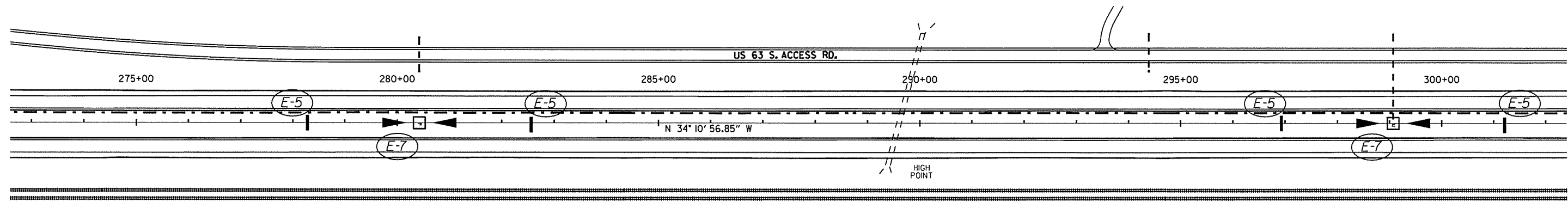

		REVISIONS	
SAND BAG DITCH CHECK	DROP INLET SILT FENCE	DATE OF REVISION	REVISION

INDICATES DIRECTION OF MEDIAN DRAINAGE

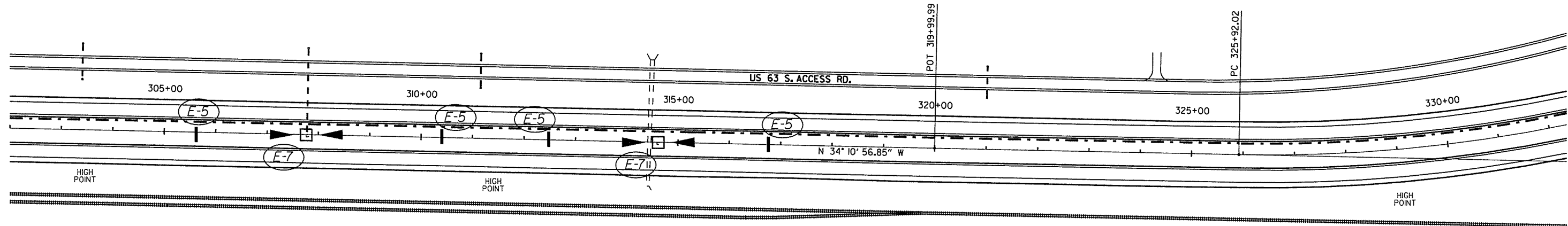

TEMPORARY EROSION CONTROL DETAILS
STA. 273+00 - STA. 332+00

P:\10003809\CADD\CEI\SHEETS\HWY 63\HWY63_EC-6.dgn 7/11/2014 11:02:16 AM

DATE REVISED	DATE FILMED	DATE REVISED	DATE FILMED	FED. RD. DIST. NO.	STATE	FED. AID PROJ. NO.	SHEET NO.	TOTAL SHEETS
				6	ARK.			
JOB NO. 02196							15	88



TEMPORARY EROSION CONTROL DETAILS

P.I. = 332+54.17
 Δ = 26° 01' 43.11" (LT)
D = 2° 00' 00.00"
T = 662.14
L = 1,301.43
R = 2,864.79

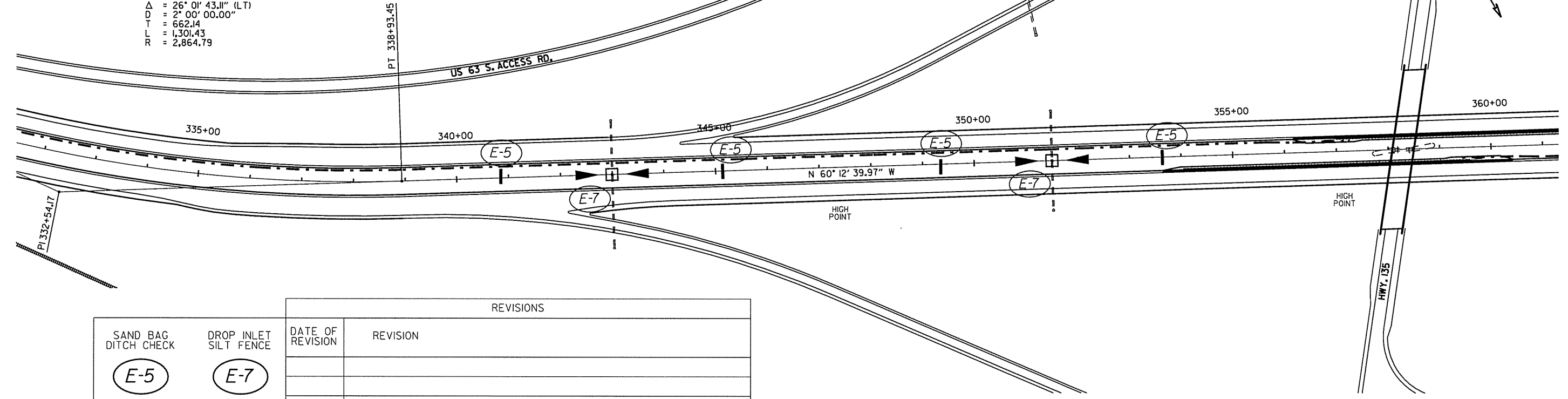

REVISIONS		DATE OF REVISION	REVISION

INDICATES DIRECTION OF MEDIAN DRAINAGE

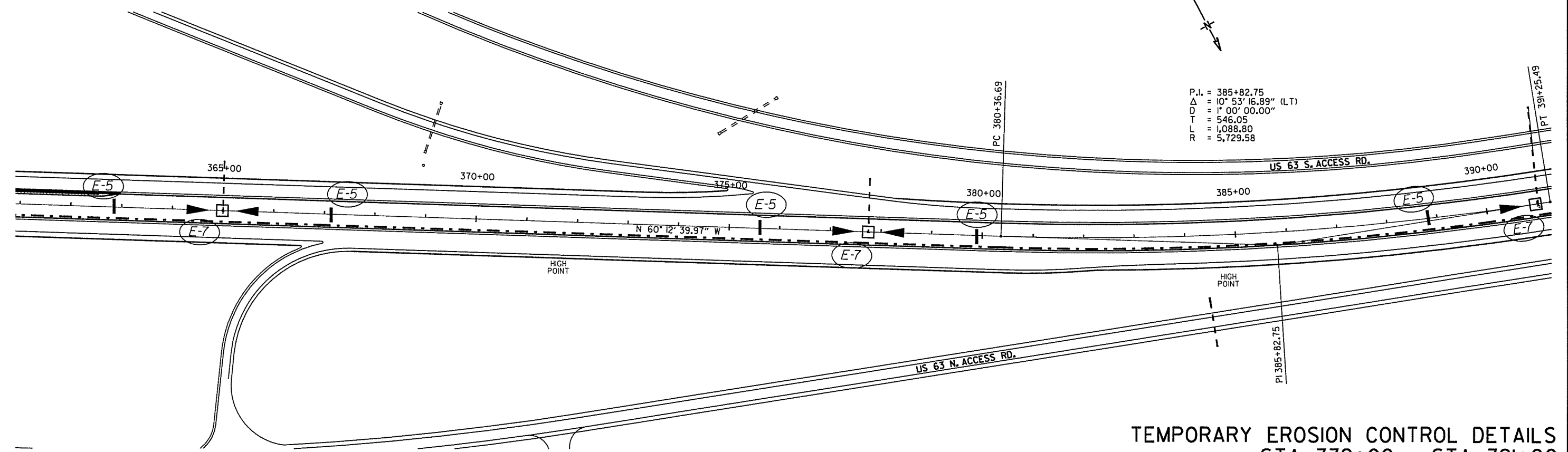

TEMPORARY EROSION CONTROL DETAILS
STA. 332+00 - STA. 391+00

7/11/2014 11:02:11 AM P:\00038109\CADD\CEI\SHEETS\HWY 63\HWY63_EC-7.dgn



DATE REVISED	DATE FILMED	DATE REVISED	DATE FILMED	FED. RD. DIST. NO.	STATE	FED. AID PROJ. NO.	SHEET NO.	TOTAL SHEETS
				6	ARK.			
JOB NO. 012196							16	88

TEMPORARY EROSION CONTROL DETAILS

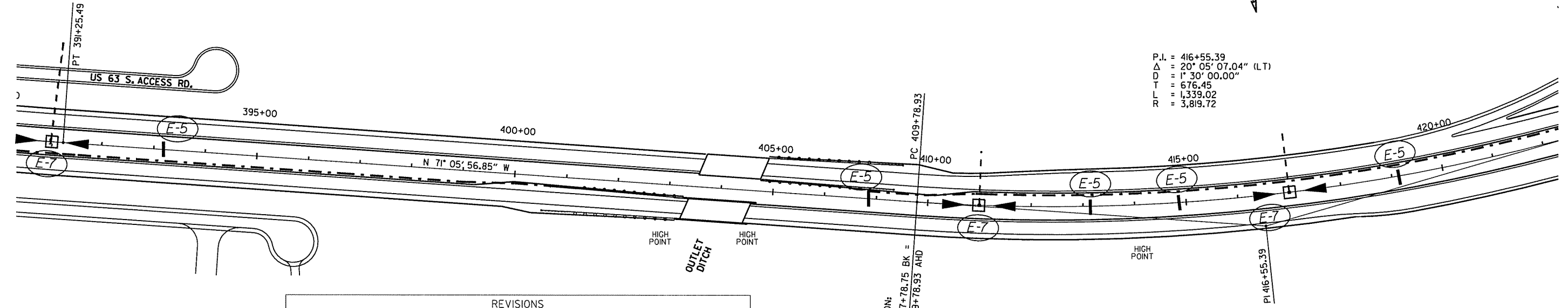

P.I. = 416+55.39
 Δ = 20° 05' 07.04" (LT)
 D = 1° 30' 00.00"
 T = 676.45
 L = 1,339.02
 R = 3,819.72

EQUATION:
 STA. 407+78.75 BK =
 STA. 409+78.93 AHD

REVISIONS		DATE OF REVISION	REVISION
	SAND BAG DITCH CHECK		
	DROP INLET SILT FENCE		

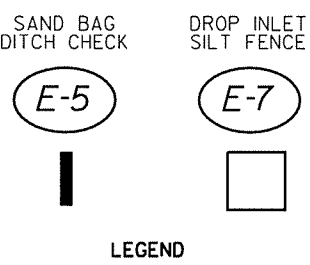

INDICATES DIRECTION OF MEDIAN DRAINAGE

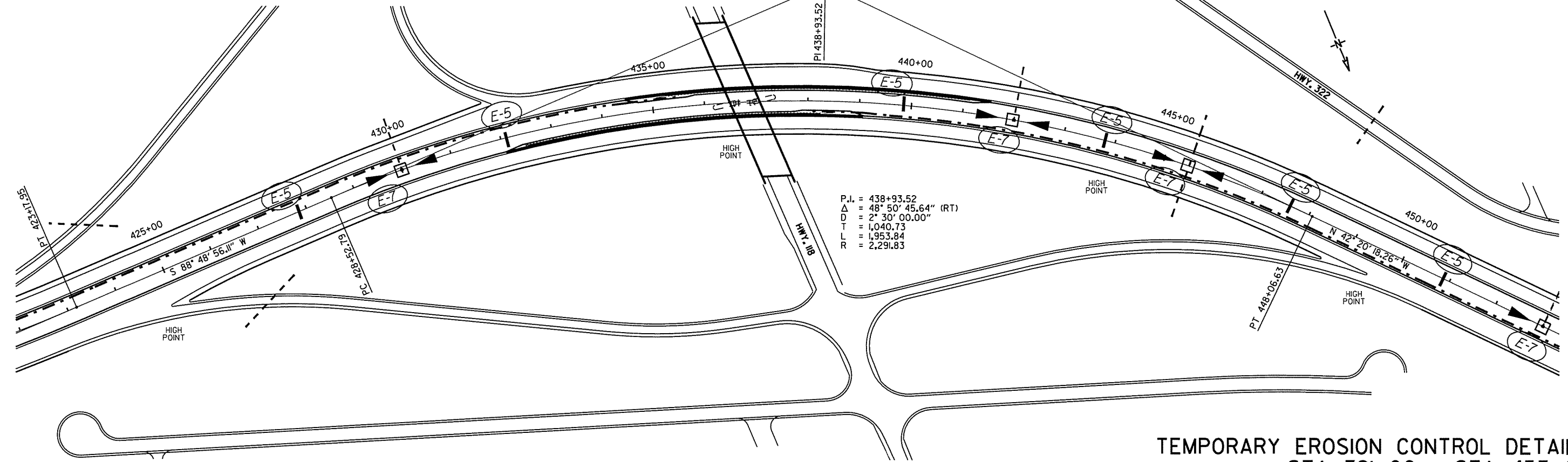

P.I. = 438+93.52
 Δ = 48° 50' 45.64" (RT)
 D = 2° 30' 00.00"
 T = 1,040.73
 L = 1,953.84
 R = 2,291.83

TEMPORARY EROSION CONTROL DETAILS
 STA. 391+00 - STA. 453+00

7/11/2014 11:02:17 AM P:\00038109\CADD\CSHETS\HWY 63\HWY63_EC-B.dwg



DATE REVISED	DATE FILMED	DATE REVISED	DATE FILMED	FED. RD. DIST. NO.	STATE	FED. AID PROJ. NO.	SHEET NO.	TOTAL SHEETS
				6	ARK.			
						JOB NO.	012196	17
TEMPORARY EROSION CONTROL DETAILS								

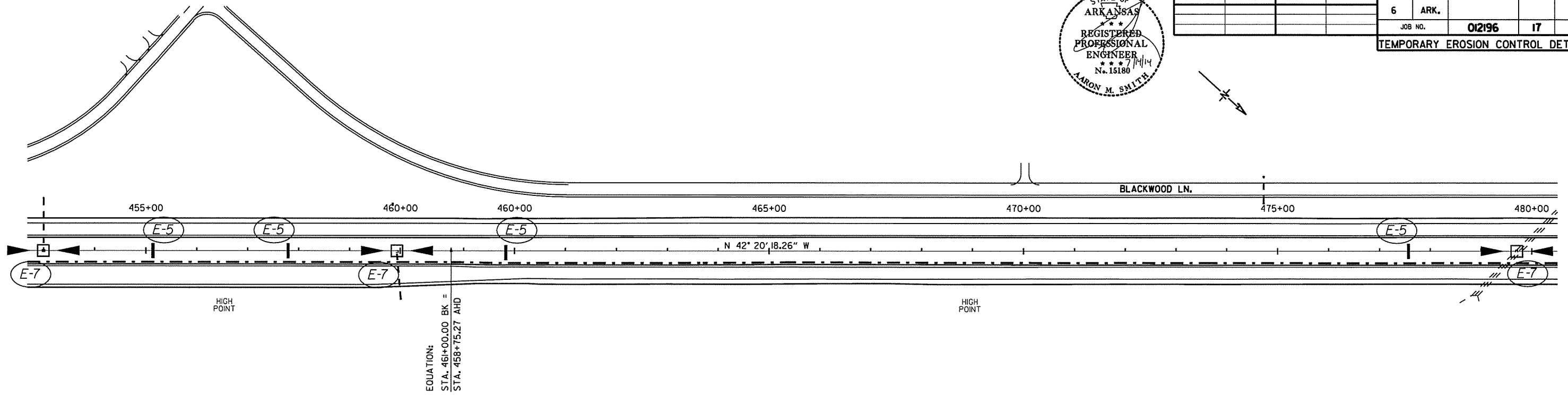

EQUATION:
STA. 461+00.00 BK =
STA. 458+75.27 AHD

		REVISIONS	
DATE OF REVISION	REVISION	DATE OF REVISION	REVISION

LEGEND

SAND BAG DITCH CHECK
E-5
|

DROP INLET SILT FENCE
E-7
□

INDICATES DIRECTION OF MEDIAN DRAINAGE

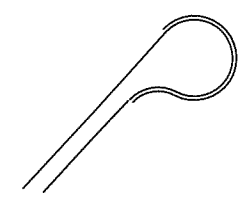
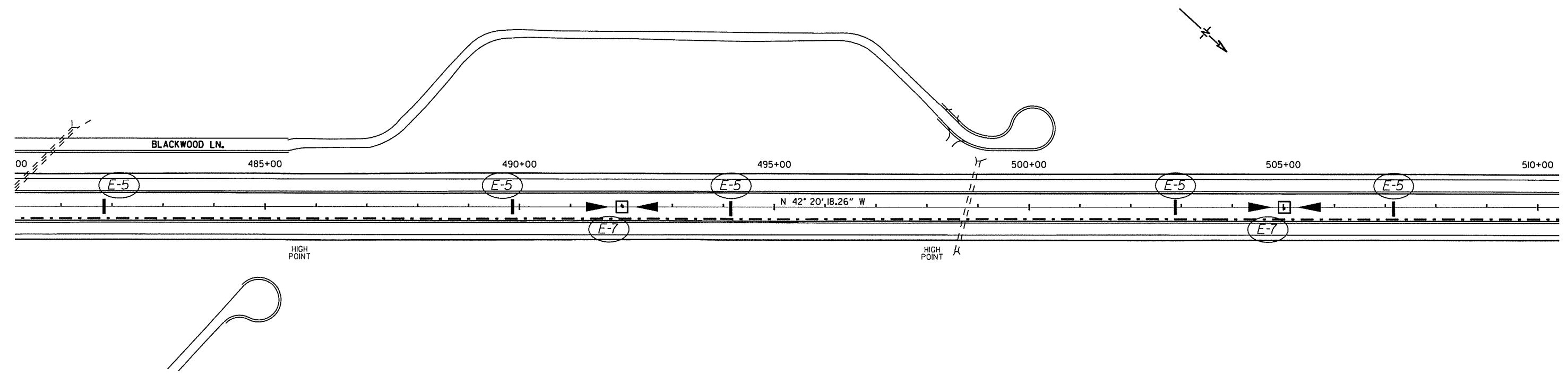

TEMPORARY EROSION CONTROL DETAILS
STA. 453+00 - STA. 510+00

7/17/2014 11:02:18 AM P:\100038109\CADD\CSHETS\HWY 63\HWY63_EC-9.dgn



DATE REVISED	DATE FILMED	DATE REVISED	DATE FILMED	FED. RD. DIST. NO.	STATE	FED. AID PROJ. NO.	SHEET NO.	TOTAL SHEETS
				6	ARK.			
				JOB NO.		012196	18	88

TEMPORARY EROSION CONTROL DETAILS

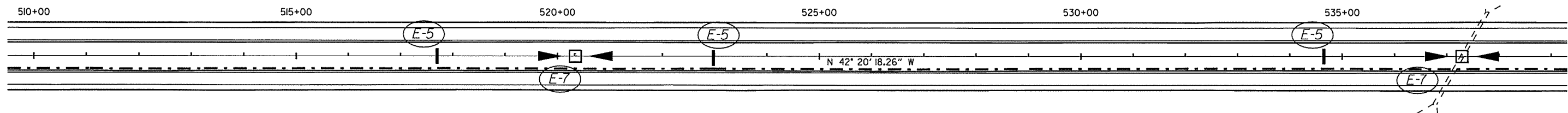

LEGEND		REVISIONS	
		DATE OF REVISION	REVISION

INDICATES DIRECTION OF MEDIAN DRAINAGE

P.I. = 559+81.60
 Δ = 4° 00' 00.00" (LT)
 D = 1° 00' 00.00"
 T = 200.08
 L = 400.00
 R = 5,729.58

STA. 564+60.00
SECTION 9
END WRSF
ON SB FORESLOPE
LOG MILE 2.88

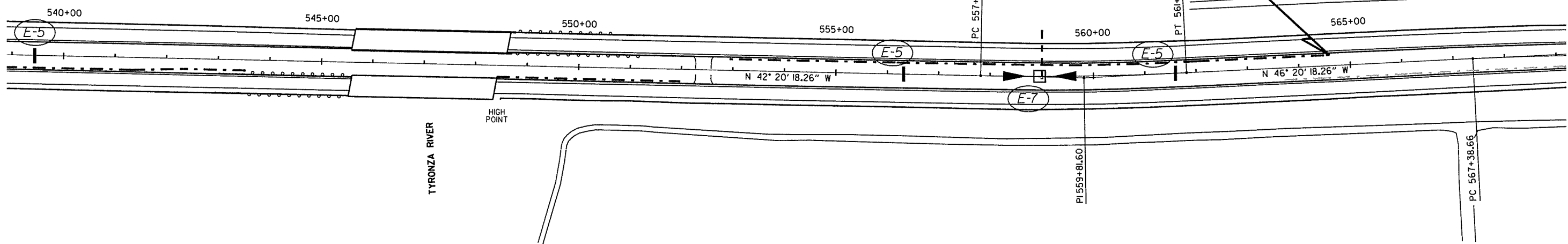

TEMPORARY EROSION CONTROL DETAILS
 STA. 510+00 - STA. 569+00

1/17/2014 11:02:18 AM P:\100038109\CADD\CEI\SHEETS\HWY 63\HWY63_EC-10.dgn

DATE REVISED	DATE FILMED	DATE REVISED	DATE FILMED	FED. RD. DIST. NO.	STATE	FED. AID PROJ. NO.	SHEET NO.	TOTAL SHEETS
				6	ARK.			
JOB NO. 012196							19	88



TEMPORARY EROSION CONTROL DETAILS

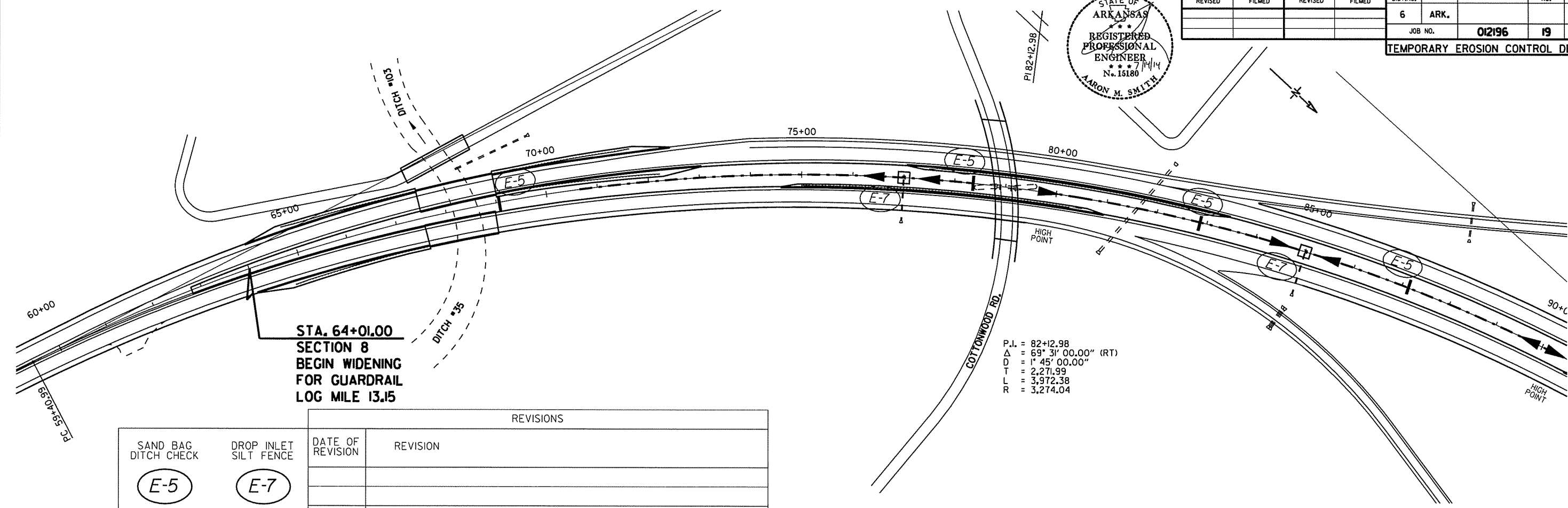

P.I. = 82+12.98
 Δ = 69° 31' 00.00" (RT)
D = 1' 45' 00.00"
T = 2,271.99
L = 3,972.38
R = 3,274.04

STA. 64+01.00
SECTION 8
BEGIN WIDENING
FOR GUARDRAIL
LOG MILE 13.15

REVISIONS		DATE OF REVISION	REVISION
	SAND BAG DITCH CHECK		
	DROP INLET SILT FENCE		

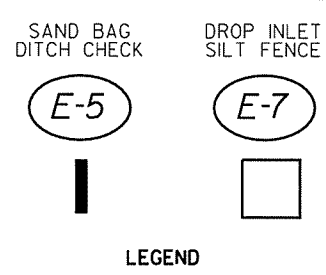

INDICATES DIRECTION OF MEDIAN DRAINAGE

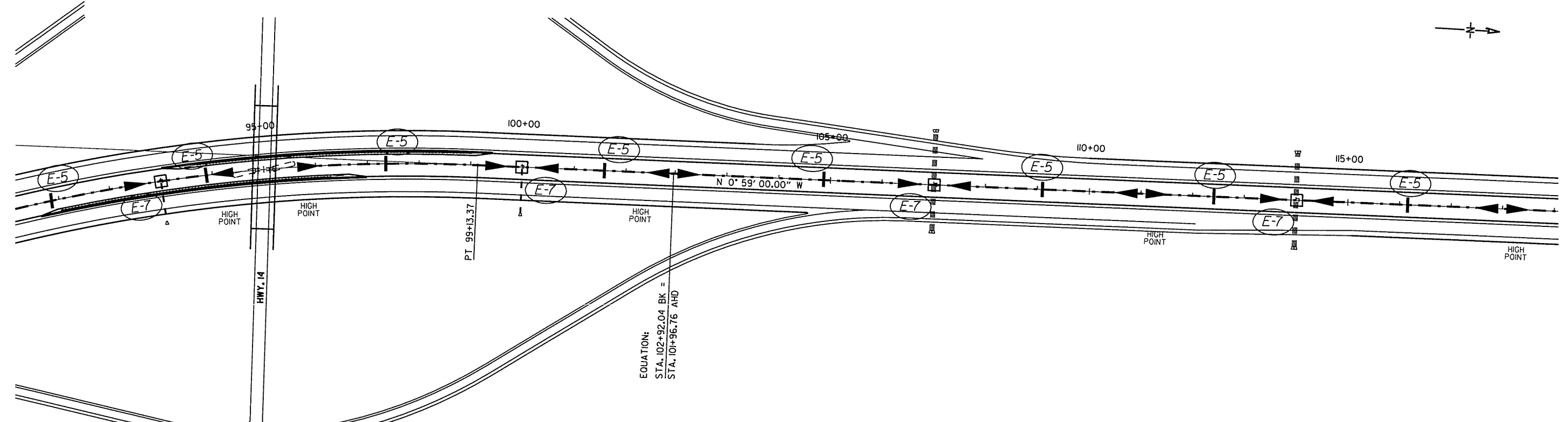

EQUATION:
STA. 102+92.04 BK =
STA. 101+96.76 AHD

TEMPORARY EROSION CONTROL DETAILS
STA. 60+00 - STA. 119+00

P:\100038103\CADD\CEI\SHEETS\HWY_63\HWY63_EC-11.dgn 7/11/2014 11:02:19 AM



DATE REVISED	DATE FILMED	DATE REVISED	DATE FILMED	FED. RD. DIST. NO.	STATE	FED. AID PROJ. NO.	SHEET NO.	TOTAL SHEETS
				6	ARK.			
				JOB NO.	012196		20	88

TEMPORARY EROSION CONTROL DETAILS

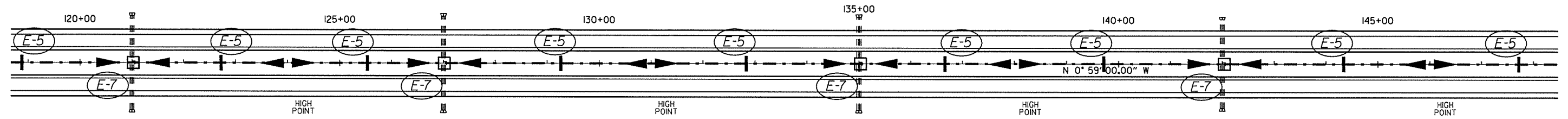
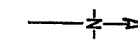

LEGEND		REVISIONS	
SAND BAG DITCH CHECK	DROP INLET SILT FENCE	DATE OF REVISION	REVISION

INDICATES DIRECTION OF MEDIAN DRAINAGE

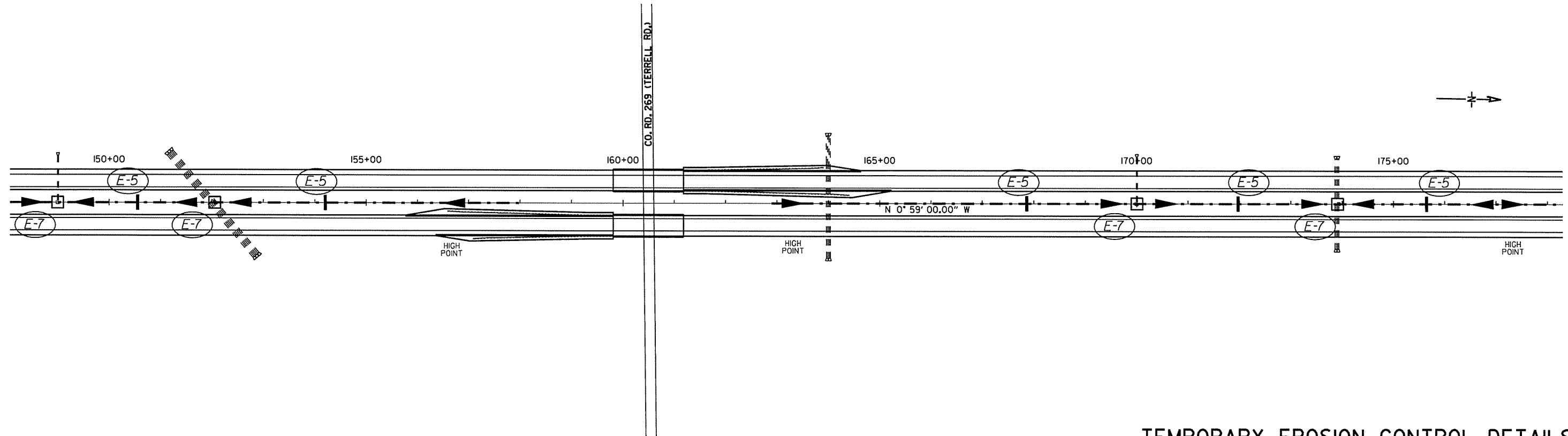

TEMPORARY EROSION CONTROL DETAILS
STA. 119+00 - STA. 178+00

7/1/2014
11:02:19 AM
P:\100038109\CADD\SET SHEETS\HWY 63\HWY63_EC-12.dgn



DATE REVISED	DATE FILMED	DATE REVISED	DATE FILMED	FED. RD. DIST. NO.	STATE	FED. AID PROJ. NO.	SHEET NO.	TOTAL SHEETS	
				6	ARK.				
							JOB NO. 02196	21	88

TEMPORARY EROSION CONTROL DETAILS

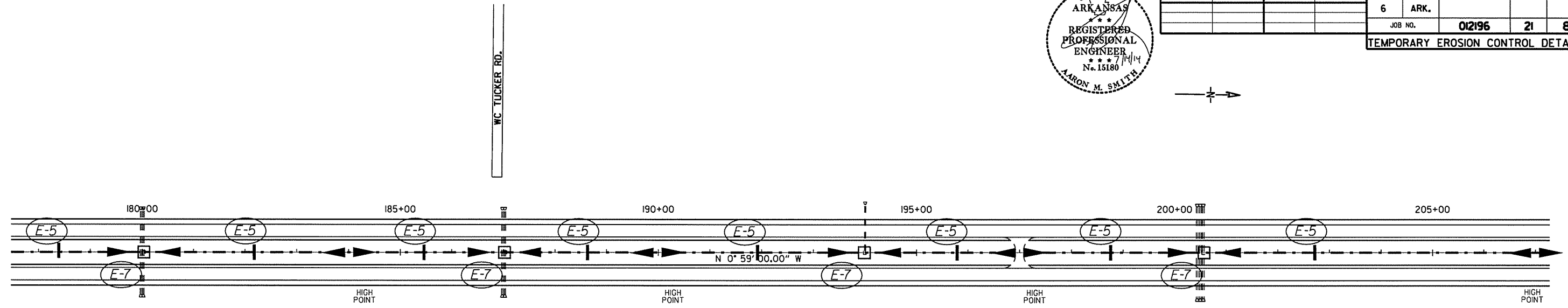
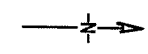

LEGEND		REVISIONS	
SAND BAG DITCH CHECK E-5 	DROP INLET SILT FENCE E-7 □	DATE OF REVISION	REVISION

INDICATES DIRECTION OF MEDIAN DRAINAGE

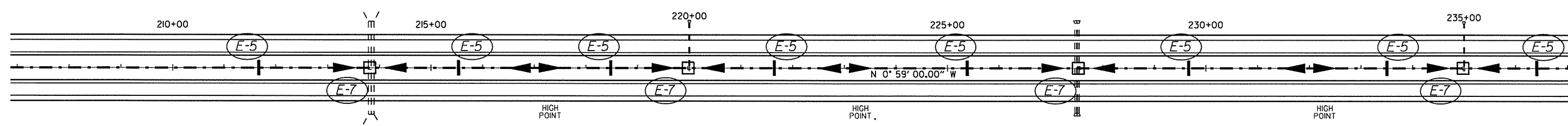
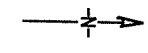

TEMPORARY EROSION CONTROL DETAILS
STA. 178+00 - STA. 237+00

7/11/2014 11:02:19 AM P:\100038109\CADD\CSHETS\HWY 63\HWY63_EC-13.dgn



DATE REVISED	DATE FILMED	DATE REVISED	DATE FILMED	FED. RD. DIST. NO.	STATE	FED. AID PROJ. NO.	SHEET NO.	TOTAL SHEETS	
				6	ARK.				
JOB NO.							012196	22	88

TEMPORARY EROSION CONTROL DETAILS

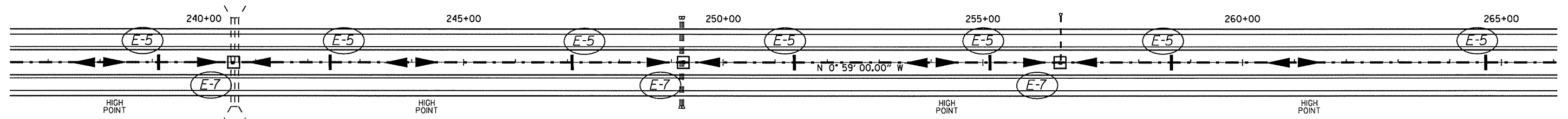
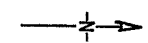

LEGEND		REVISIONS	
SAND BAG DITCH CHECK E-5 	DROP INLET SILT FENCE E-7 □	DATE OF REVISION	REVISION

INDICATES DIRECTION OF MEDIAN DRAINAGE

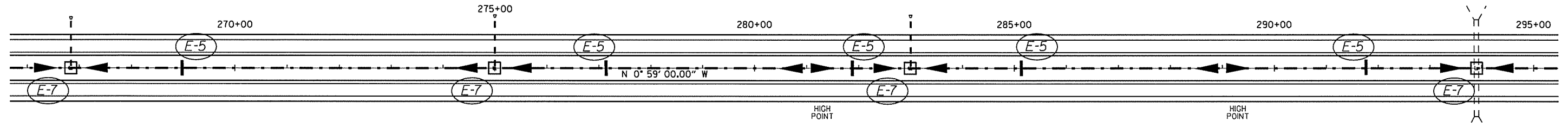
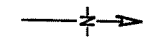

TEMPORARY EROSION CONTROL DETAILS
STA. 237+00 - STA. 295+00

7/17/2014 11:02:15 AM P:\00038109\CADD\CSHETS\HWY 63\HWY63_EC-14.dgn



DATE REVISED	DATE FILMED	DATE REVISED	DATE FILMED	FED. RD. DIST. NO.	STATE	FED. AID PROJ. NO.	SHEET NO.	TOTAL SHEETS
				6	ARK.			
JOB NO. 012196							23	88

TEMPORARY EROSION CONTROL DETAILS

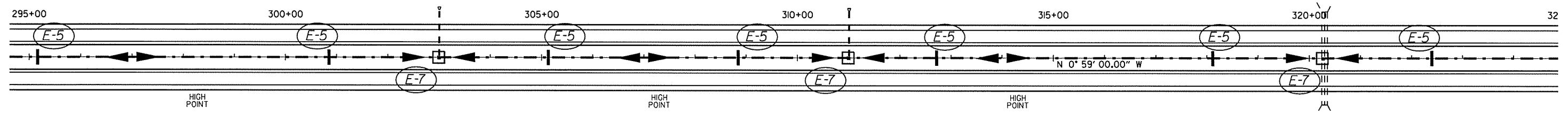

LEGEND		REVISIONS	
SAND BAG DITCH CHECK 	DROP INLET SILT FENCE 	DATE OF REVISION	REVISION

INDICATES DIRECTION OF MEDIAN DRAINAGE

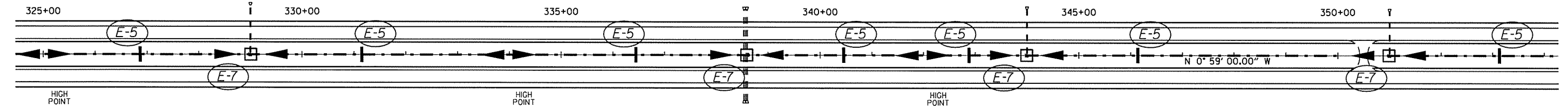

TEMPORARY EROSION CONTROL DETAILS
STA. 295+00 - STA. 354+00

7/1/2014 11:02:20 AM P:\00038109\CADD\CSHETS\HWY 63\HWY63_EC-15.dgn



DATE REVISED	DATE FILMED	DATE REVISED	DATE FILMED	FED. RD. DIST. NO.	STATE	FED. AID PROJ. NO.	SHEET NO.	TOTAL SHEETS
				6	ARK.			
				JOB NO.	02196	24	88	

P.I. = 383+26.74
 Δ = 36° 21' 41.00" (LT)
 D = 2° 00' 00.00"
 T = 940.83
 L = 1,818.07
 R = 2,864.79

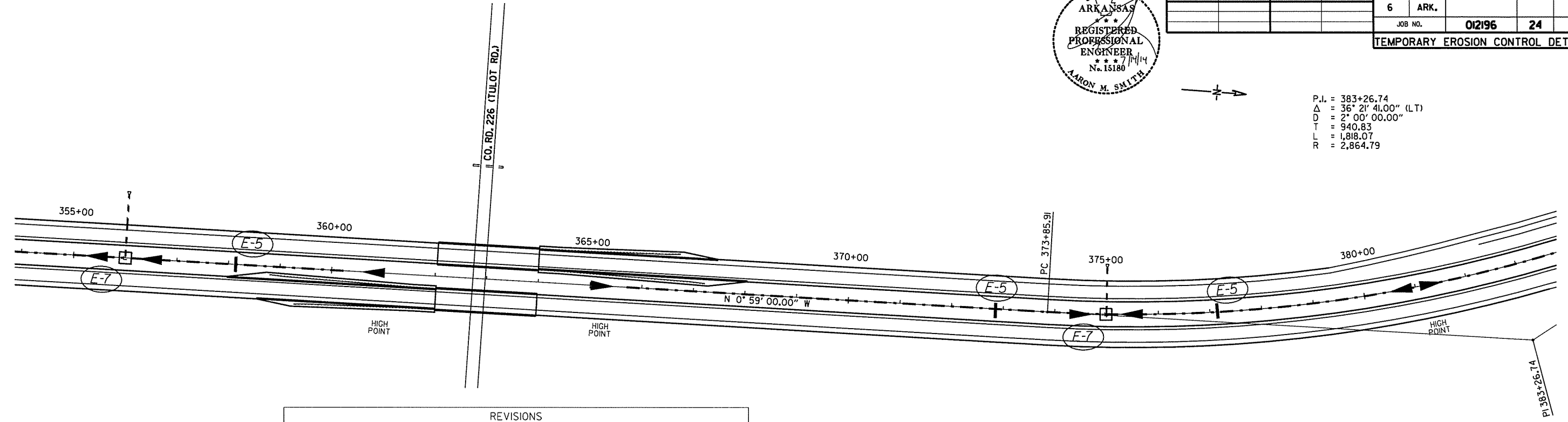

REVISIONS		DATE OF REVISION	REVISION

LEGEND

SAND BAG DITCH CHECK:

DROP INLET SILT FENCE:

INDICATES DIRECTION OF MEDIAN DRAINAGE

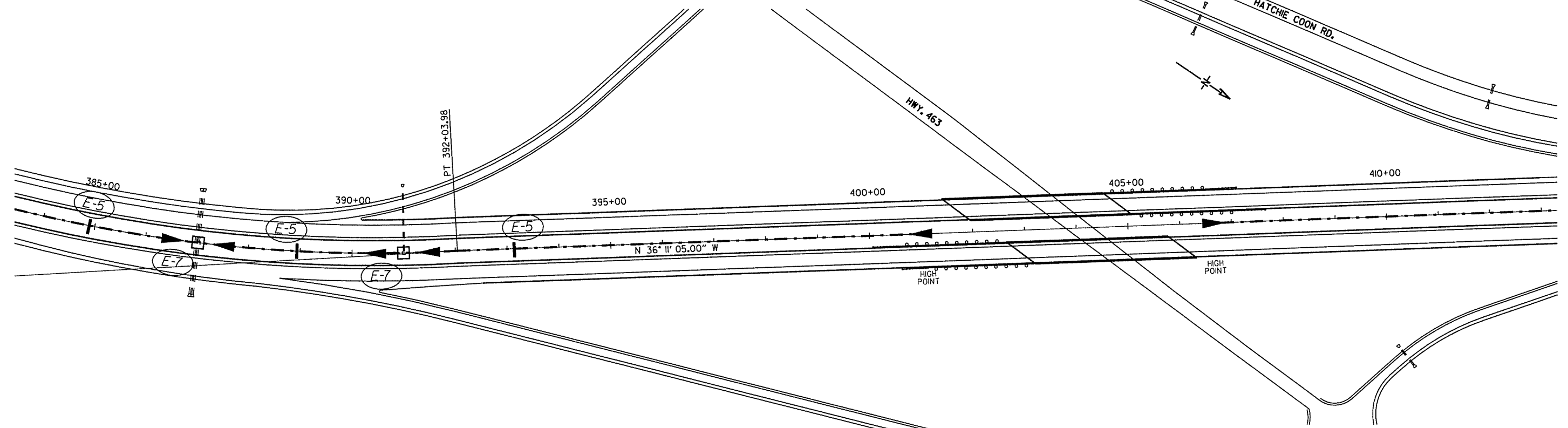

**TEMPORARY EROSION CONTROL DETAILS
 STA. 354+00 - STA. 413+00**

7/11/2014 11:02:20 AM P:\00038109\CADD\SHEETS\HWY 63\HWY63_EC-16.dgn



DATE REVISED	DATE FILMED	DATE REVISED	DATE FILMED	FED. RD. DIST. NO.	STATE	FED. AID PROJ. NO.	SHEET NO.	TOTAL SHEETS
				6	ARK.			
						JOB NO.	012196	25
TEMPORARY EROSION CONTROL DETAILS								

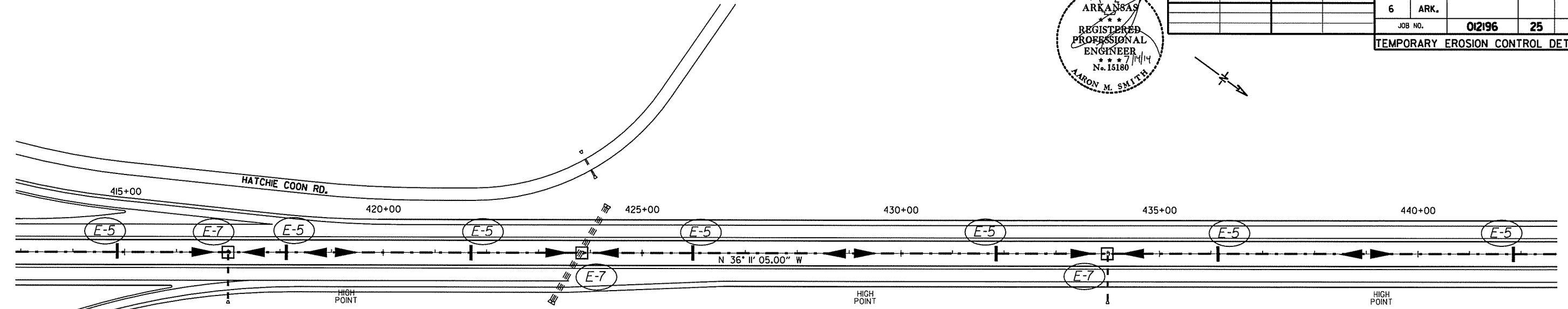

		REVISIONS	
SAND BAG DITCH CHECK	DROP INLET SILT FENCE	DATE OF REVISION	REVISION
E-5 	E-7 □		

INDICATES DIRECTION OF MEDIAN DRAINAGE

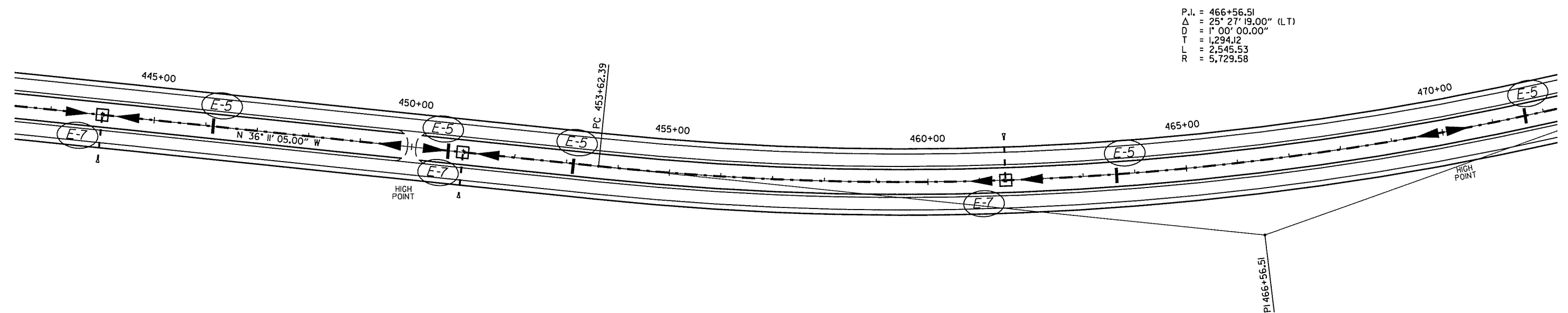

P.I. = 466+56.51
 Δ = 25° 27' 19.00" (LT)
 D = 1° 00' 00.00"
 T = 1,294.12
 L = 2,545.53
 R = 5,729.58

TEMPORARY EROSION CONTROL DETAILS
 STA. 413+00 - STA. 472+00

7/17/2014 10:02:20 AM P:\10003809\CADD\CET\SHEETS\HWY 63\HWY63_EC-T7.dgn



DATE REVISED	DATE FILMED	DATE REVISED	DATE FILMED	FED. RD. DIST. NO.	STATE	FED. AID PROJ. NO.	SHEET NO.	TOTAL SHEETS
				6	ARK.			
						JOB NO.	012196	26
TEMPORARY EROSION CONTROL DETAILS								

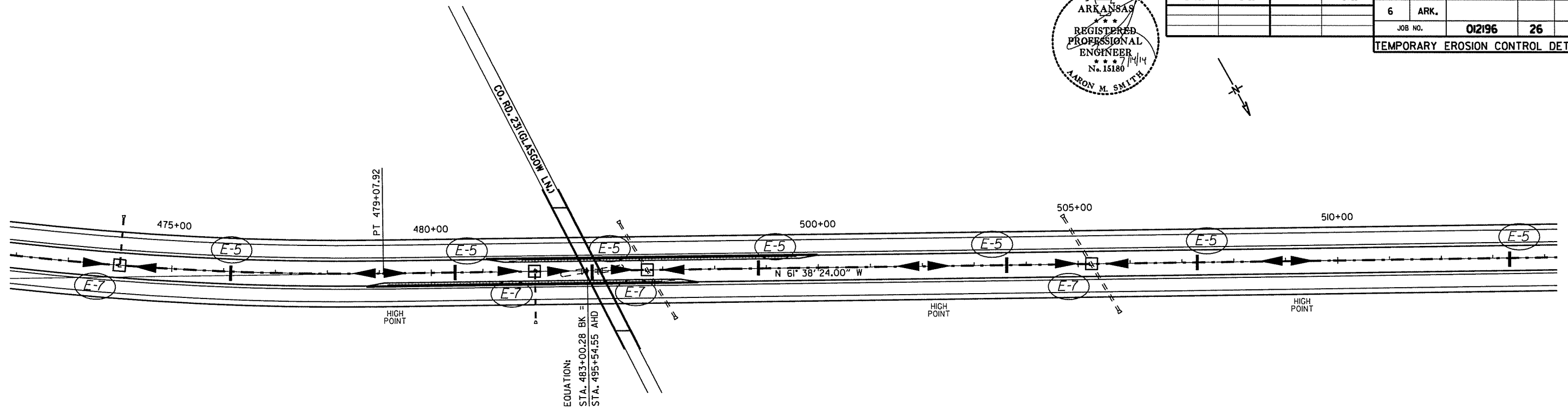

LEGEND		REVISIONS	
SAND BAG DITCH CHECK	DROP INLET SILT FENCE	DATE OF REVISION	REVISION

INDICATES DIRECTION OF MEDIAN DRAINAGE

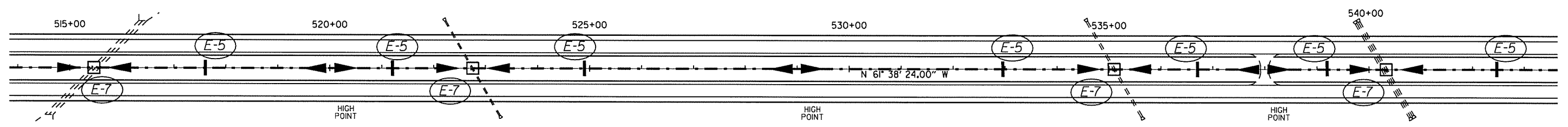

TEMPORARY EROSION CONTROL DETAILS
STA. 472+00 - STA. 543+00

7/17/2014 11:02:21 AM P:\100038105\CADD\CET\SHEETS\HWY 63\HWY63_EC-18.dgn



DATE REVISED	DATE FILMED	DATE REVISED	DATE FILMED	FED. RD. DIST. NO.	STATE	FED. AID PROJ. NO.	SHEET NO.	TOTAL SHEETS	
				6	ARK.				
							JOB NO. 02196	27	88

TEMPORARY EROSION CONTROL DETAILS

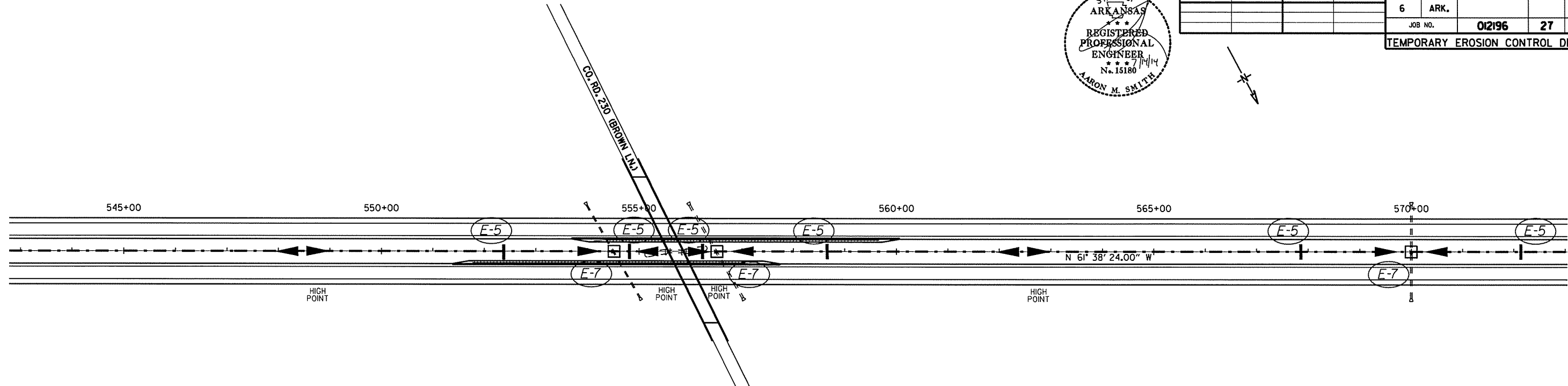

LEGEND		REVISIONS	
SAND BAG DITCH CHECK E-5 	DROP INLET SILT FENCE E-7 □	DATE OF REVISION	REVISION

INDICATES DIRECTION OF MEDIAN DRAINAGE

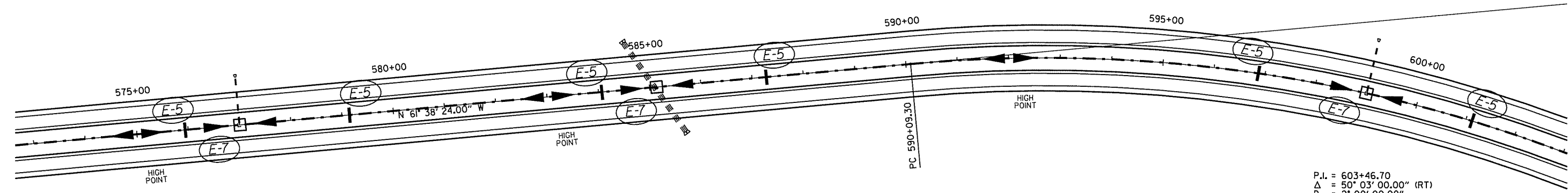

P.I. = 603+46.70
 Δ = 50° 03' 00.00" (RT)
 D = 2° 00' 00.00"
 T = 1,337.40
 L = 2,502.50
 R = 2,864.79

TEMPORARY EROSION CONTROL DETAILS
 STA. 543+00 - STA. 603+00

7/11/2014 10:02:21 AM P:\100038109\CADD\CEI\SHEETS\HWY 63\HWY63_EC-19.dwg



DATE REVISED	DATE FILMED	DATE REVISED	DATE FILMED	FED. RD. DIST. NO.	STATE	FED. AID PROJ. NO.	SHEET NO.	TOTAL SHEETS
				6	ARK.			
						JOB NO.	012196	28

TEMPORARY EROSION CONTROL DETAILS

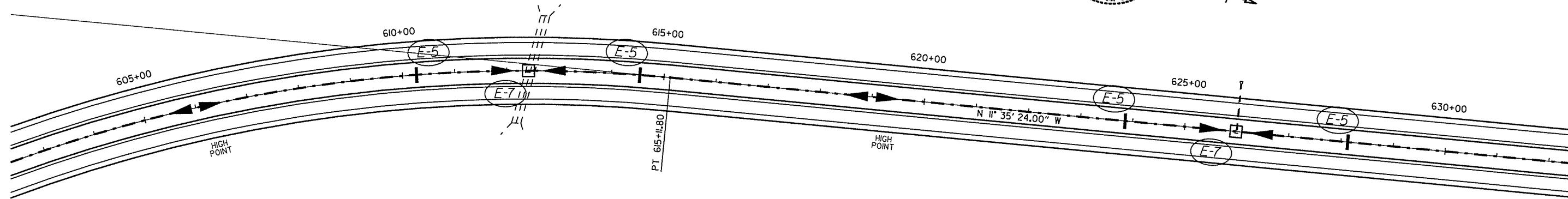

P.I. = 603+46.70
 Δ = 50° 03' 00.00" (RT)
 D = 2° 00' 00.00"
 T = 1,337.40
 L = 2,502.50
 R = 2,864.79

		REVISIONS	
SAND BAG DITCH CHECK	DROP INLET SILT FENCE	DATE OF REVISION	REVISION

LEGEND

INDICATES DIRECTION OF MEDIAN DRAINAGE

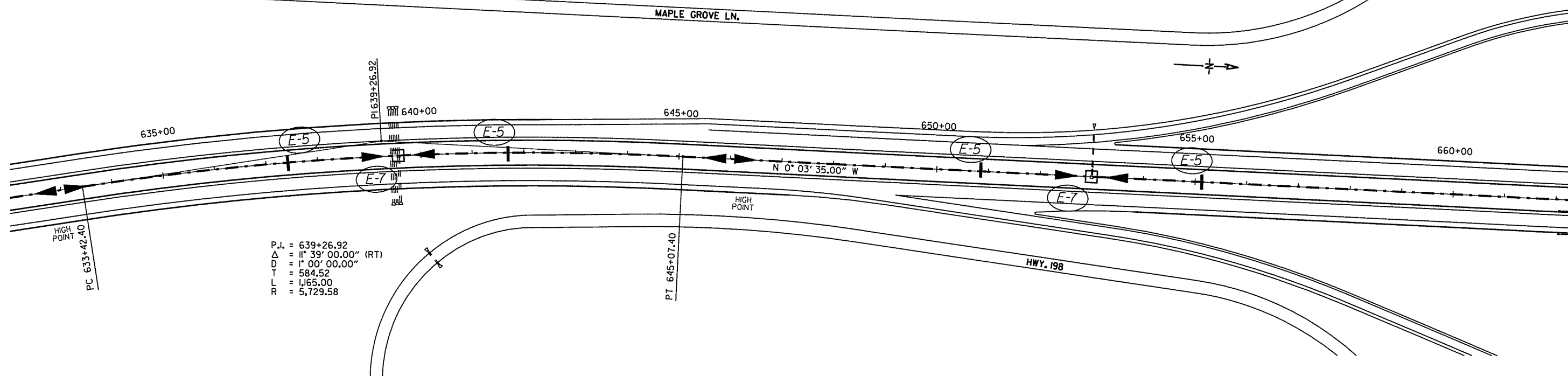

P.I. = 639+26.92
 Δ = 11° 39' 00.00" (RT)
 D = 1° 00' 00.00"
 T = 584.52
 L = 1,165.00
 R = 5,729.58

TEMPORARY EROSION CONTROL DETAILS
 STA. 603+00 - STA. 662+00

7/11/2014 11:02:21 AM P:\100038109\CADD\GEI\SHEETS\HWY_63\HWY63_EC-20.dgn



DATE REVISED	DATE FILMED	DATE REVISED	DATE FILMED	FED. RD. DIST. NO.	STATE	FED. AID PROJ. NO.	SHEET NO.	TOTAL SHEETS
				6	ARK.		29	88

TEMPORARY EROSION CONTROL DETAILS

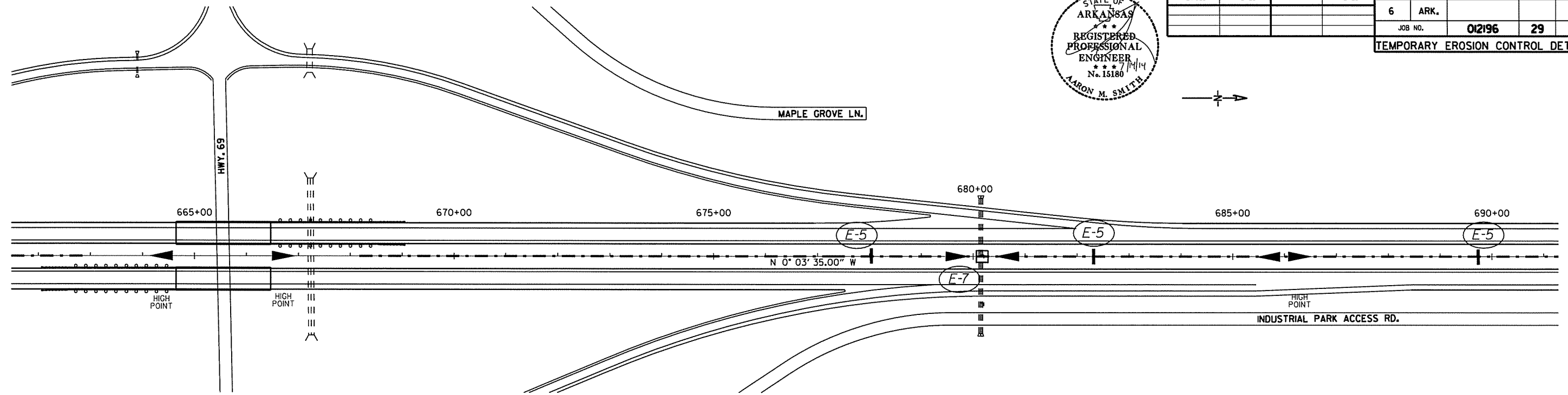

REVISIONS		DATE OF REVISION	REVISION

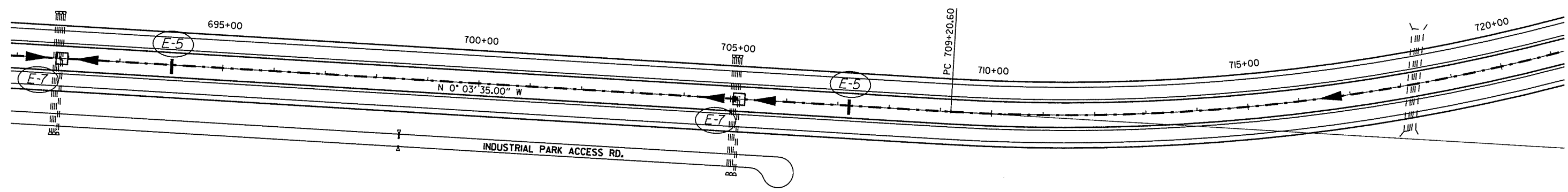
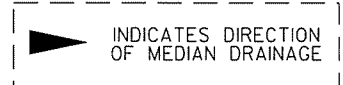
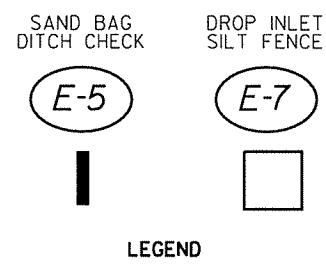

TEMPORARY EROSION CONTROL DETAILS
STA. 662+00 - STA. 721+00

7/11/2014 11:02:22 AM P:\100038109\CADD\SET SHEETS\HWY 63\HWY63 EC-21.dwg



DATE REVISED	DATE FILMED	DATE REVISED	DATE FILMED	FED. RD. DIST. NO.	STATE	FED. AID PROJ. NO.	SHEET NO.	TOTAL SHEETS	
				6	ARK.				
JOB NO.							012196	30	88

TEMPORARY EROSION CONTROL DETAILS

P.I. = 725+33.45
 Δ = 45° 47' 00.00" (LT)
 D = 1' 30' 00.04"
 T = 1,612.85
 L = 3,052.20
 R = 3,819.69

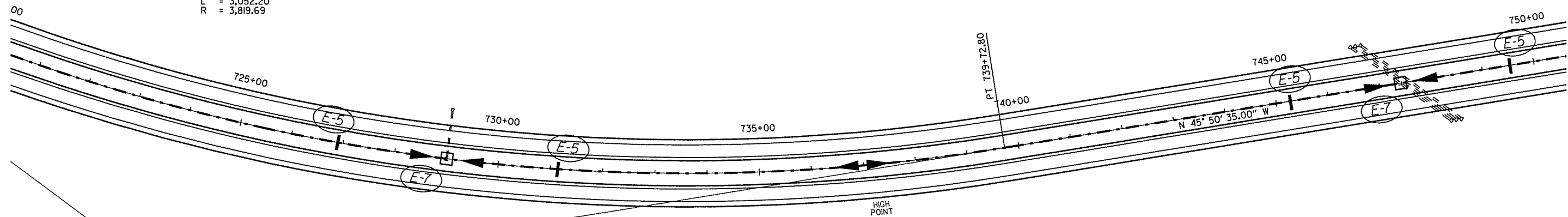

REVISIONS		DATE OF REVISION	REVISION
	SAND BAG DITCH CHECK		
	DROP INLET SILT FENCE		

LEGEND

INDICATES DIRECTION OF MEDIAN DRAINAGE

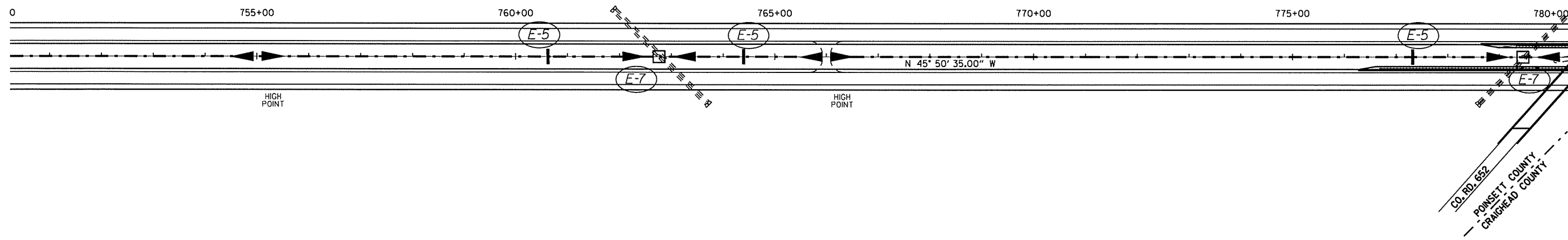

TEMPORARY EROSION CONTROL DETAILS
 STA. 721+00 - STA. 780+00

7/11/2014 11:02:22 AM P:\00038105\CADD\CEI SHEETS\HWY 63\HWY63_EC-22.dgn



DATE REVISED	DATE FILMED	DATE REVISED	DATE FILMED	FED. RD. DIST. NO.	STATE	FED. AID PROJ. NO.	SHEET NO.	TOTAL SHEETS
				6	ARK.			
JOB NO. 012196							31	88

TEMPORARY EROSION CONTROL DETAILS

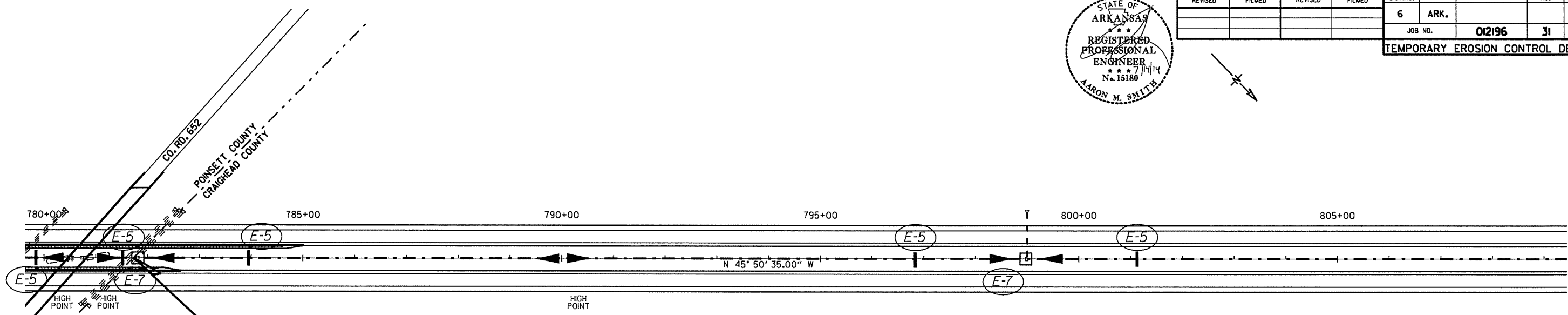

STA. 781+72.74
 END SECTION 8
 LOG MILE 0.00
 BEGIN SECTION 7
 LOG MILE 12.42

		REVISIONS	
SAND BAG DITCH CHECK	DROP INLET SILT FENCE	DATE OF REVISION	REVISION

LEGEND

INDICATES DIRECTION OF MEDIAN DRAINAGE

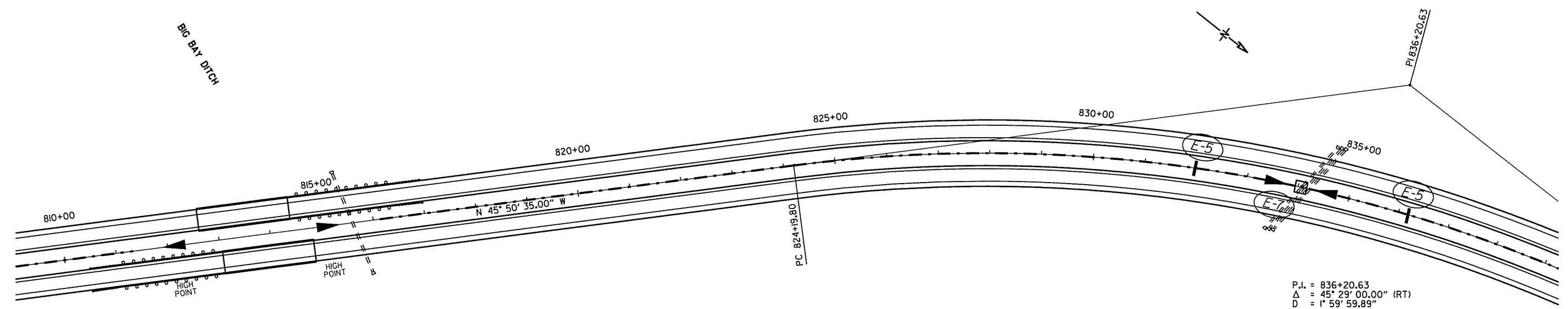

P.I. = 836+20.63
 Δ = 45° 29' 00.00" (RT)
 D = 1° 59' 59.89"
 T = 1,200.83
 L = 2,274.20
 R = 2,864.83

TEMPORARY EROSION CONTROL DETAILS
 STA. 780+00 - STA. 839+00

7/17/2014 11:02:22 AM P:\100038109\CADD\CEI\SHEETS\HWY 63\HWY63_EC-23.dgn



DATE REVISED	DATE FILMED	DATE REVISED	DATE FILMED	FED. RD. DIST. NO.	STATE	FED. AID PROJ. NO.	SHEET NO.	TOTAL SHEETS
				6	ARK.			
JOB NO. 02196							32	88

TEMPORARY EROSION CONTROL DETAILS

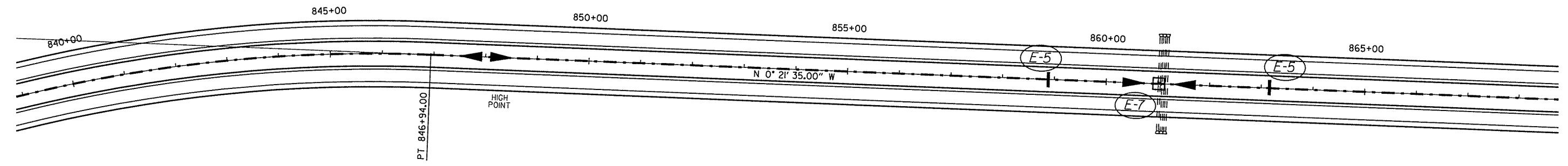

		REVISIONS	
SAND BAG DITCH CHECK	DROP INLET SILT FENCE	DATE OF REVISION	REVISION

LEGEND

INDICATES DIRECTION OF MEDIAN DRAINAGE

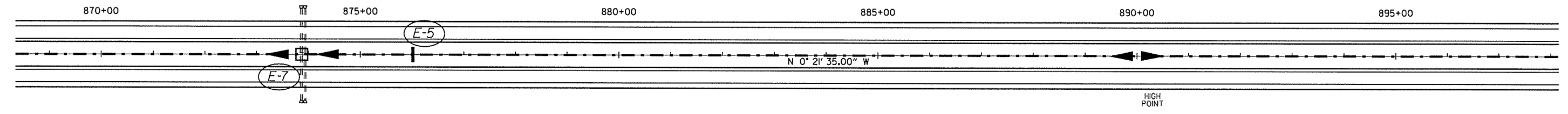

TEMPORARY EROSION CONTROL DETAILS
STA. 839+00 - STA. 898+00

7/11/2014 11:02:22 AM P:\100038109\CADD\CEI\SHEETS\HWY_63\HWY63_EC-24.dgn



DATE REVISED	DATE FILMED	DATE REVISED	DATE FILMED	FED. RD. DIST. NO.	STATE	FED. AID PROJ. NO.	SHEET NO.	TOTAL SHEETS	
				6	ARK.				
JOB NO.							02196	33	88

TEMPORARY EROSION CONTROL DETAILS

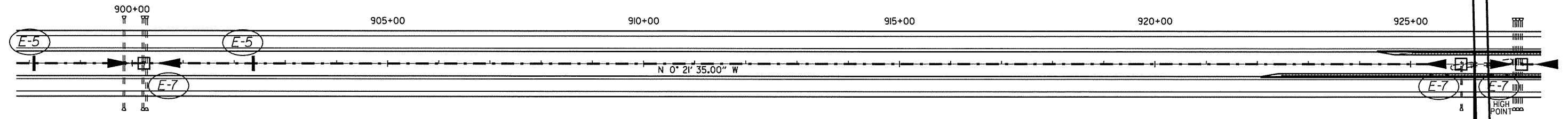

		REVISIONS	
SAND BAG DITCH CHECK	DROP INLET SILT FENCE	DATE OF REVISION	REVISION

LEGEND

INDICATES DIRECTION OF MEDIAN DRAINAGE

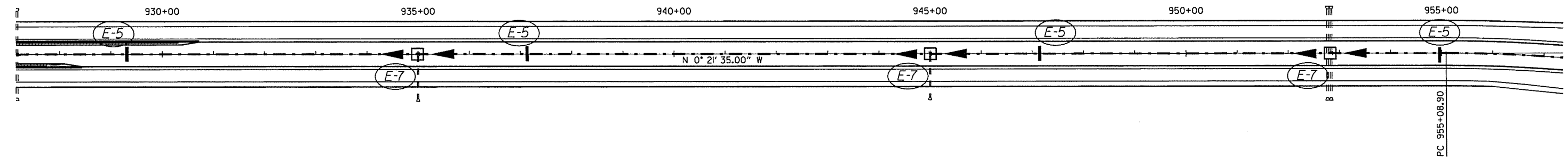

TEMPORARY EROSION CONTROL DETAILS
STA. 898+00 - STA. 957+00

7/11/2014 10:02:23 AM P:\100038109\CADD\CEI\SHEETS\HWY 63\HWY63_EC-25.dgn

DATE REVISED	DATE FILMED	DATE REVISED	DATE FILMED	FED. RD. DIST. NO.	STATE	FED. AID PROJ. NO.	SHEET NO.	TOTAL SHEETS
				6	ARK.			
						JOB NO.	012196	34
						TEMPORARY EROSION CONTROL DETAILS		

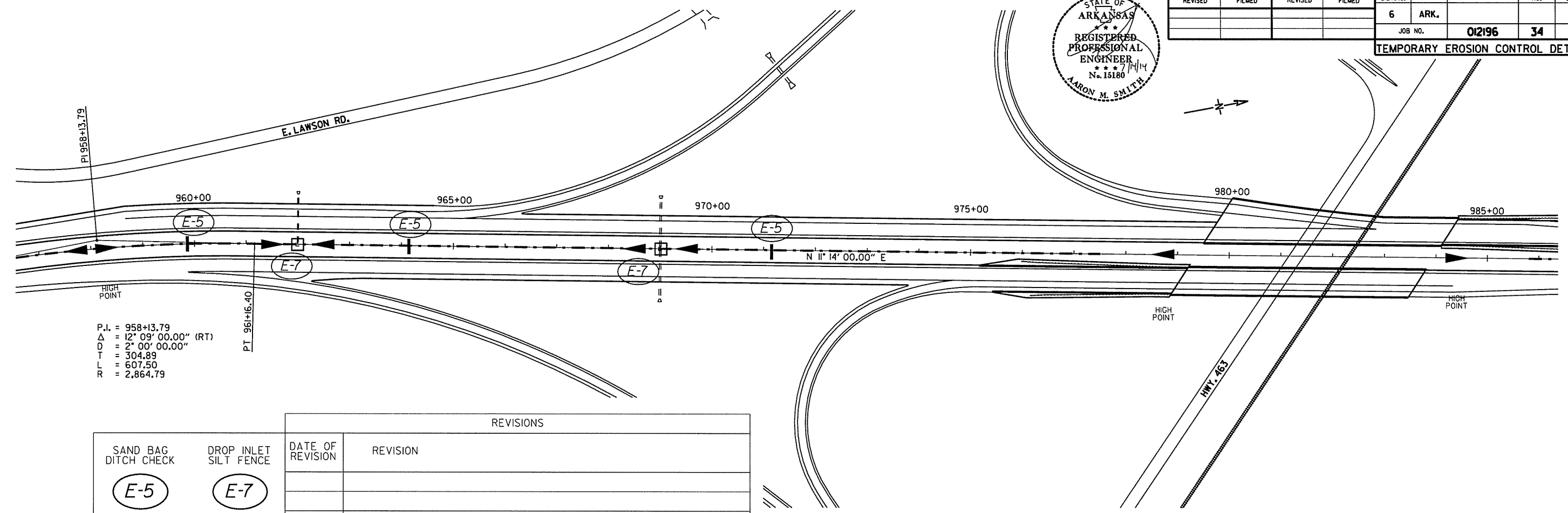

P.I. = 958+13.79
 Δ = 12° 09' 00.00" (RT)
D = 2° 00' 00.00"
T = 304.89
L = 607.50
R = 2,864.79

		REVISIONS	
SAND BAG DITCH CHECK	DROP INLET SILT FENCE	DATE OF REVISION	REVISION
LEGEND			

INDICATES DIRECTION OF MEDIAN DRAINAGE

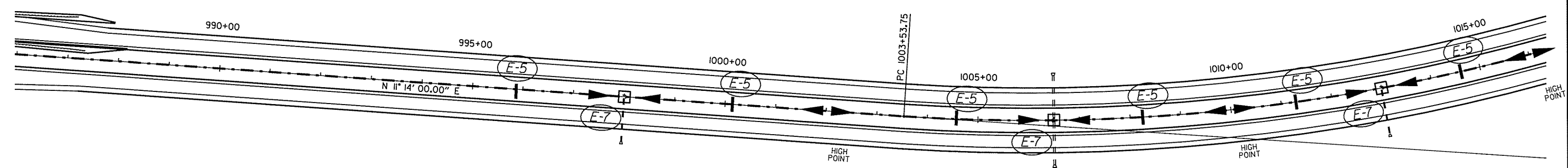

TEMPORARY EROSION CONTROL DETAILS
STA. 957+00 - STA. 1016+00

7/11/2014 11:02:23 AM P:\100038109\CADD\GEI\SHEETS\HWY 63\HWY63_EC-26.dgn



DATE REVISED	DATE FILMED	DATE REVISED	DATE FILMED	FED. RD. DIST. NO.	STATE	FED. AID PROJ. NO.	SHEET NO.	TOTAL SHEETS
				6	ARK.			
JOB NO. 012196							35	88

TEMPORARY EROSION CONTROL DETAILS

P.I. = 1027+90.31
 Δ = 65° 04' 00.00" (LT)
 D = 1' 30" 00.00"
 T = 2,436.56
 L = 4,337.78
 R = 3,819.72

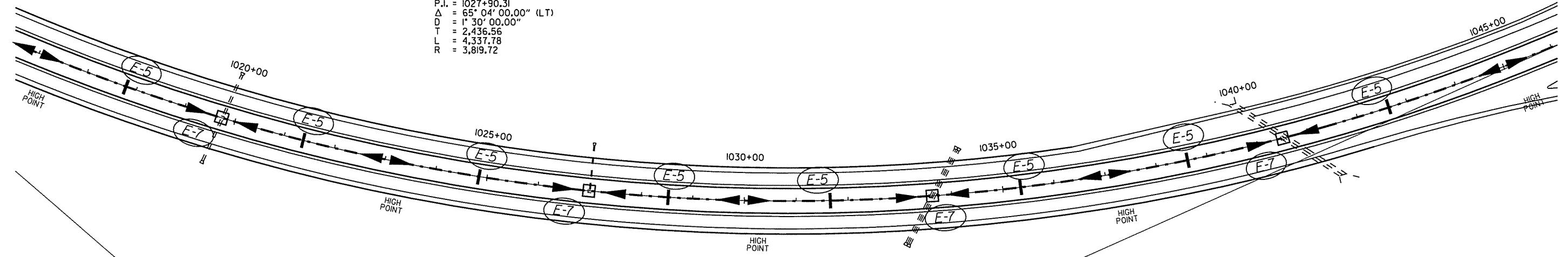

REVISIONS		DATE OF REVISION	REVISION

LEGEND

SAND BAG DITCH CHECK

DROP INLET SILT FENCE

INDICATES DIRECTION OF MEDIAN DRAINAGE

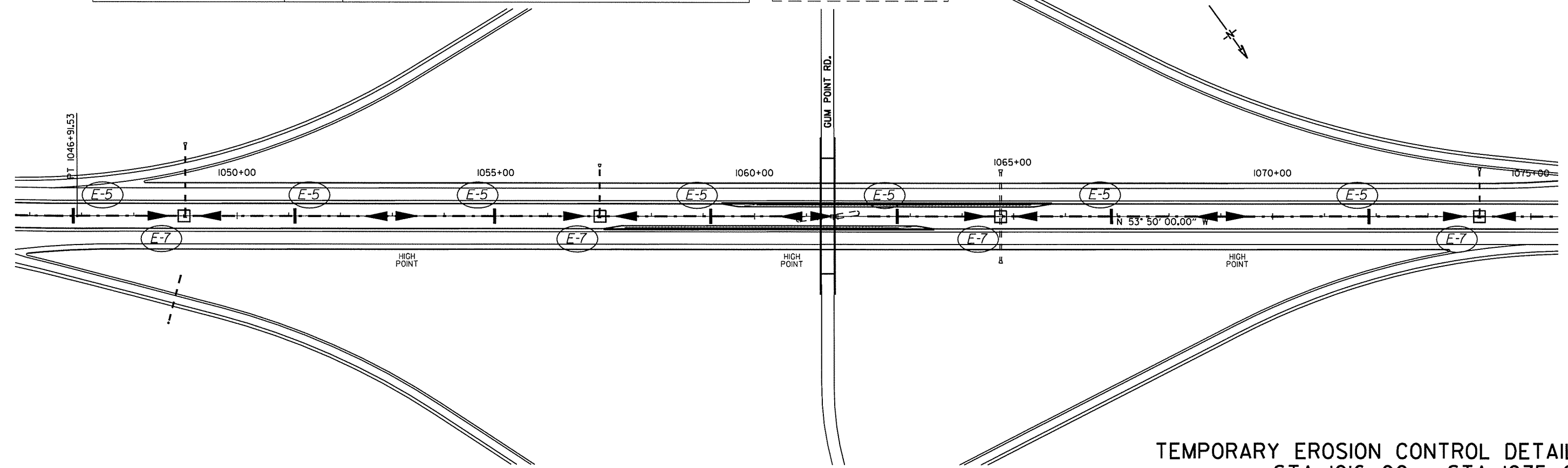

TEMPORARY EROSION CONTROL DETAILS
 STA. 1016+00 - STA. 1075+00

7/11/2014 11:08:47 AM P:\100038109\CADD\CEI\SHEETS\HWY 63\HWY63_EC-27.dgn



DATE REVISED	DATE FILMED	DATE REVISED	DATE FILMED	FED. RD. DIST. NO.	STATE	FED. AID PROJ. NO.	SHEET NO.	TOTAL SHEETS
				6	ARK.			
JOB NO. 012196							36	88

TEMPORARY EROSION CONTROL DETAILS

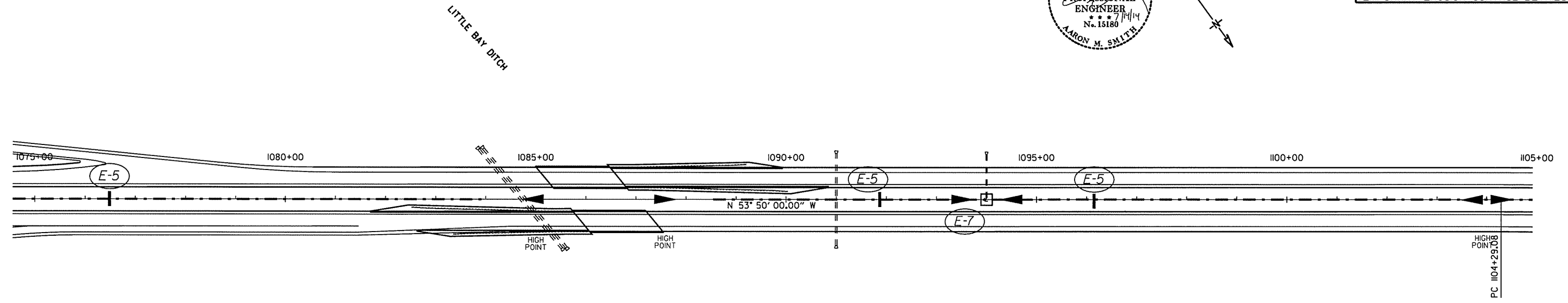

REVISIONS		DATE OF REVISION	REVISION
	SAND BAG DITCH CHECK		
	DROP INLET SILT FENCE		

INDICATES DIRECTION OF MEDIAN DRAINAGE

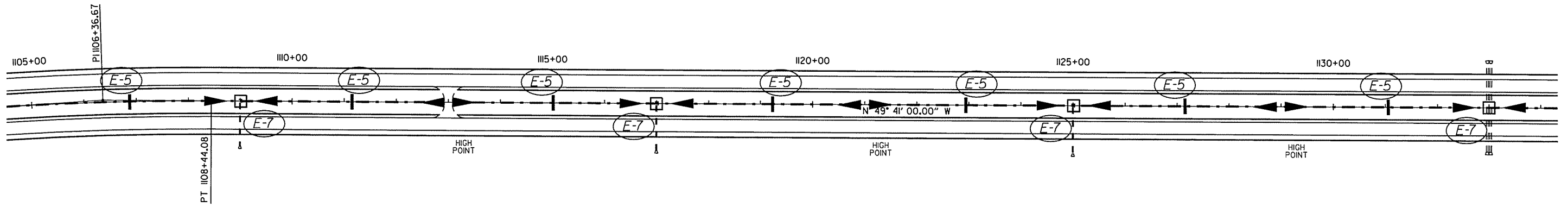

P.I. = 1106+36.67
 Δ = 4° 09' 00.00" (RT)
 D = 1° 00' 00.00"
 T = 207.59
 L = 415.00
 R = 5,729.58

TEMPORARY EROSION CONTROL DETAILS
 STA. 1075+00 - STA. 1134+00





7/17/2014 11:02:24 AM P:\100038109\CADD\SHEETS\HWY 63\HWY63_EC-28.dgn

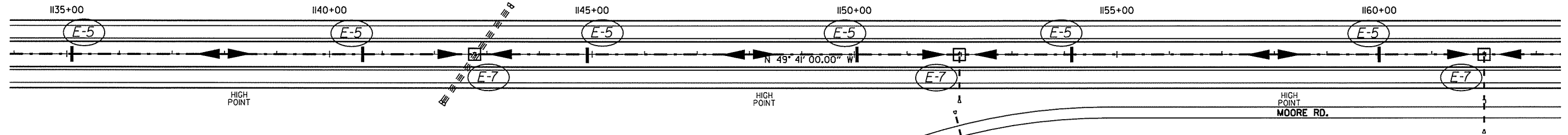

DATE REVISED	DATE FILMED	DATE REVISED	DATE FILMED	FED. RD. DIST. NO.	STATE	FED. AID PROJ. NO.	SHEET NO.	TOTAL SHEETS	
				6	ARK.				
JOB NO.							02196	37	88

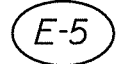
TEMPORARY EROSION CONTROL DETAILS



LEGEND		REVISIONS	
SAND BAG DITCH CHECK 	DROP INLET SILT FENCE 	DATE OF REVISION	REVISION
			

 INDICATES DIRECTION OF MEDIAN DRAINAGE

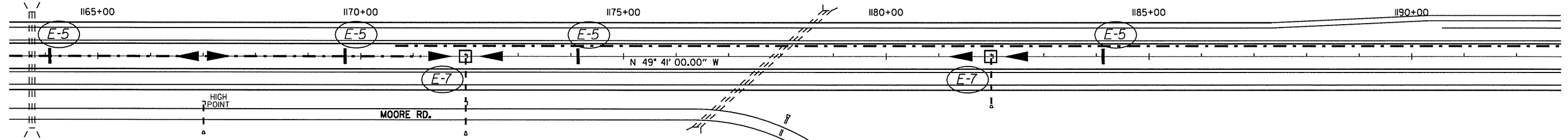

TEMPORARY EROSION CONTROL DETAILS
STA. 1134+00 - STA. 1193+00

7/11/2014 11:02:24 AM P:\00038109\CADD\CEI\SHEETS\HWY 63\HWY63_EC-29.dgn



DATE REVISED	DATE FILMED	DATE REVISED	DATE FILMED	FED. RD. DIST. NO.	STATE	FED. AID PROJ. NO.	SHEET NO.	TOTAL SHEETS
				6	ARK.			
JOB NO. 012196							38	88

TEMPORARY EROSION CONTROL DETAILS

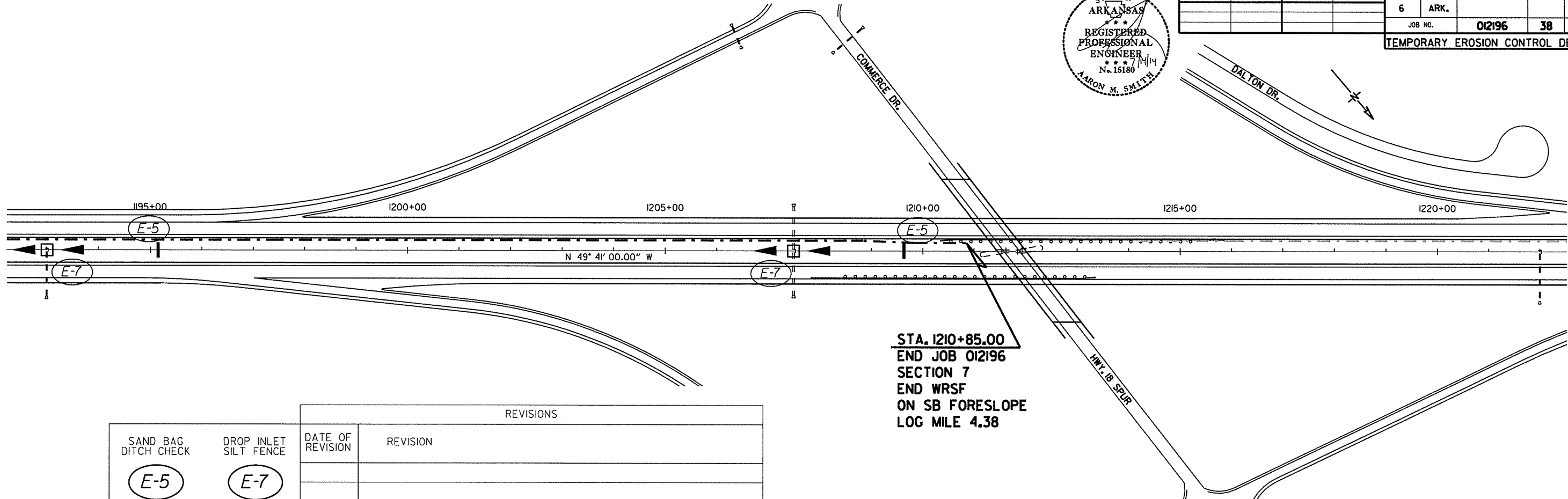

STA. 1210+85.00
 END JOB 012196
 SECTION 7
 END WRSF
 ON SB FORESLOPE
 LOG MILE 4.38

		REVISIONS	
SAND BAG DITCH CHECK	DROP INLET SILT FENCE	DATE OF REVISION	REVISION

LEGEND

INDICATES DIRECTION OF MEDIAN DRAINAGE

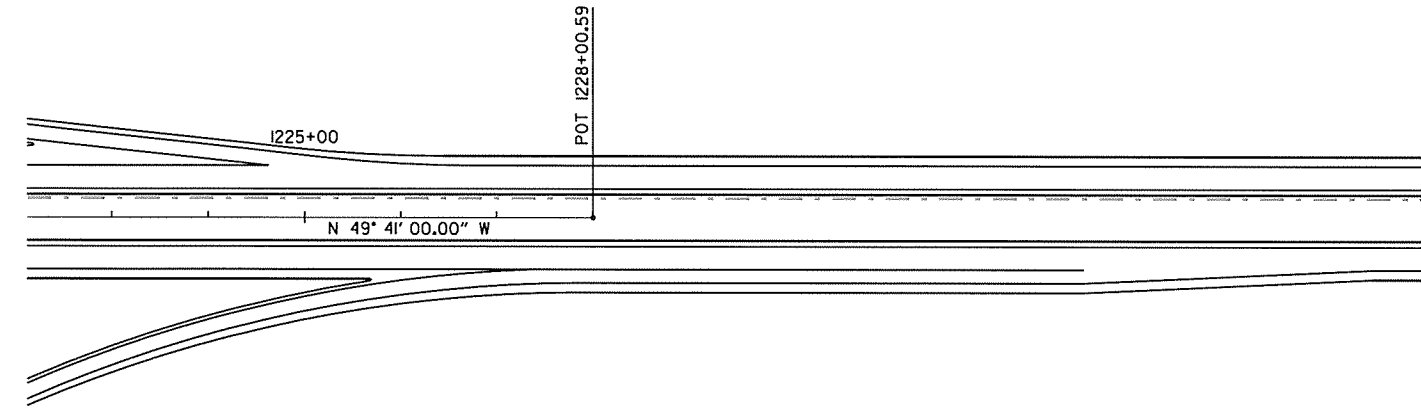

TEMPORARY EROSION CONTROL DETAILS
 STA. 1193+00 - STA. 1228+00.59

7/17/2014 11:02:24 AM P:\00038105\CADD\SHEETS\HWY 63\HWY63_EC-30.dgn



DATE REVISED	DATE FILMED	DATE REVISED	DATE FILMED	FED. RD. DIST. NO.	STATE	FED. AID PROJ. NO.	SHEET NO.	TOTAL SHEETS		
				6	ARK.					
							JOB NO.	012196	39	88
									MAINTENANCE OF TRAFFIC	

NOTE :
W20-1 (VARIOUS DISTANCE) ADVANCE SIGNS
TO BE REPLACED AS NEEDED BY EQUIVALENT W20-5 SIGNS
AS WORKING AREA SHIFTS.

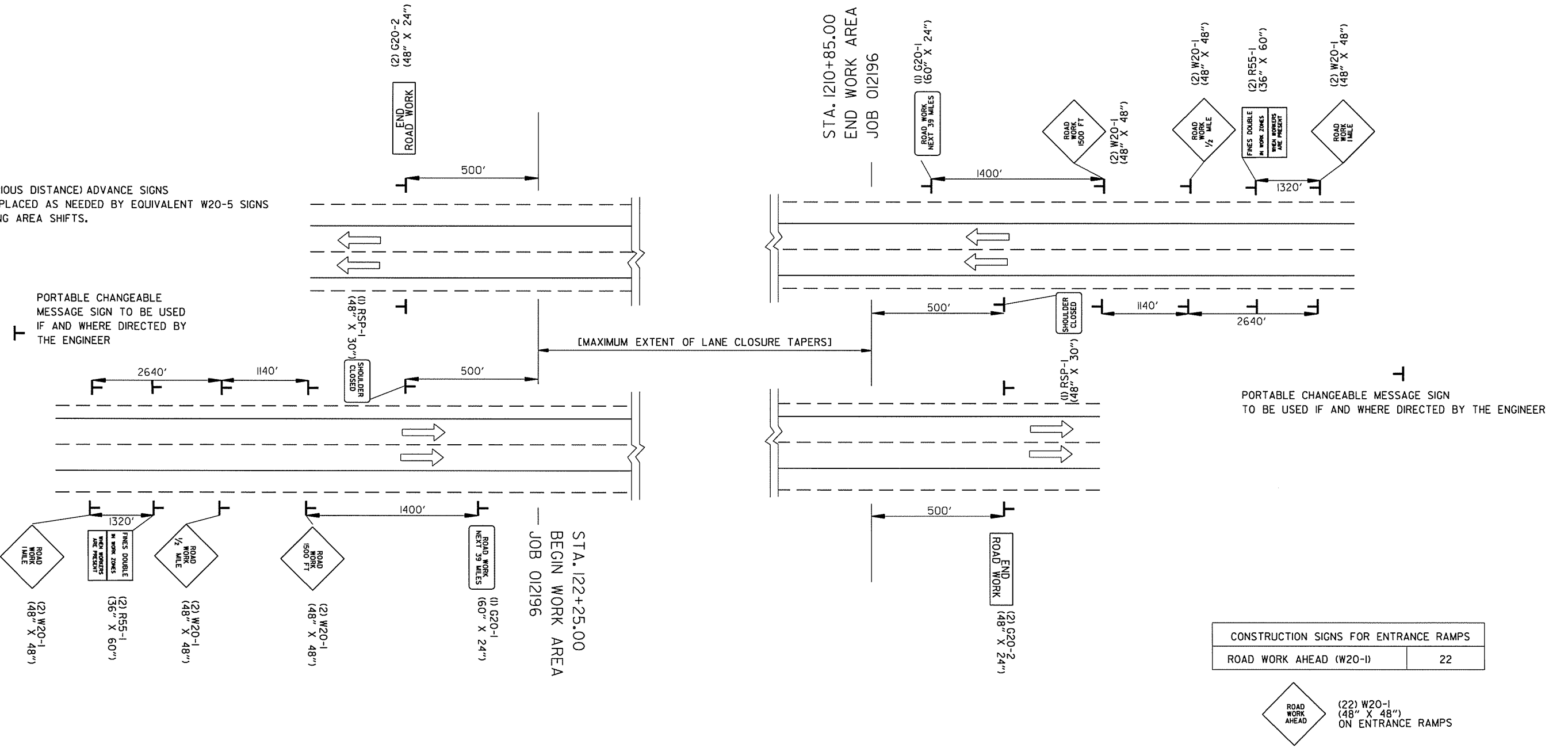

MAINTENANCE OF TRAFFIC
ADVANCE SIGNS AT JOB ENDS



DATE REVISED	DATE FILMED	DATE REVISED	DATE FILMED	FED. RD. DIST. NO.	STATE	FED. AID PROJ. NO.	SHEET NO.	TOTAL SHEETS
				6	ARK.			
						JOB NO.	012196	40
						MAINTENANCE OF TRAFFIC		

PRECAST CONCRETE BARRIER WALL (20 LOCATIONS)
 (5) FURNISH AND INSTALL = 2765 LIN. FT. (553 LIN. FT. PER INSTALLATION)
 (15) RELOCATE = 8295 LIN. FT. (553 LIN. FT. PER INSTALLATION)

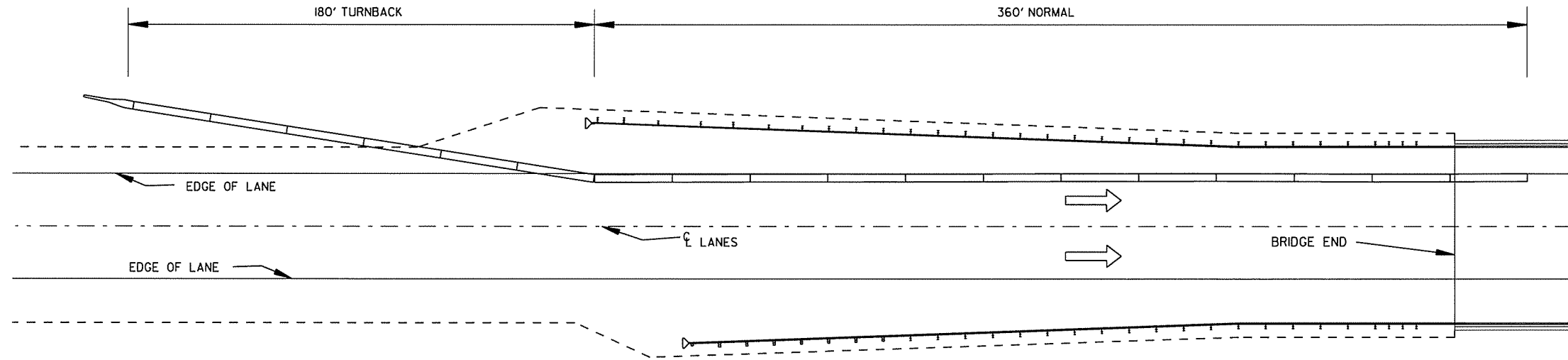

LAYOUT OF PRECAST CONCRETE BARRIER FOR LEFT APPROACH GUTTER

NOTE: ONLY ONE SIDE OF ROADWAY AT BRIDGE LOCATION SHALL BE UNDER CONSTRUCTION AT A TIME. PCB SHALL REMAIN IN PLACE FOR THE REMOVAL AND CONSTRUCTION OF APPROACH GUTTERS AND GUARDRAIL INSTALLATION.

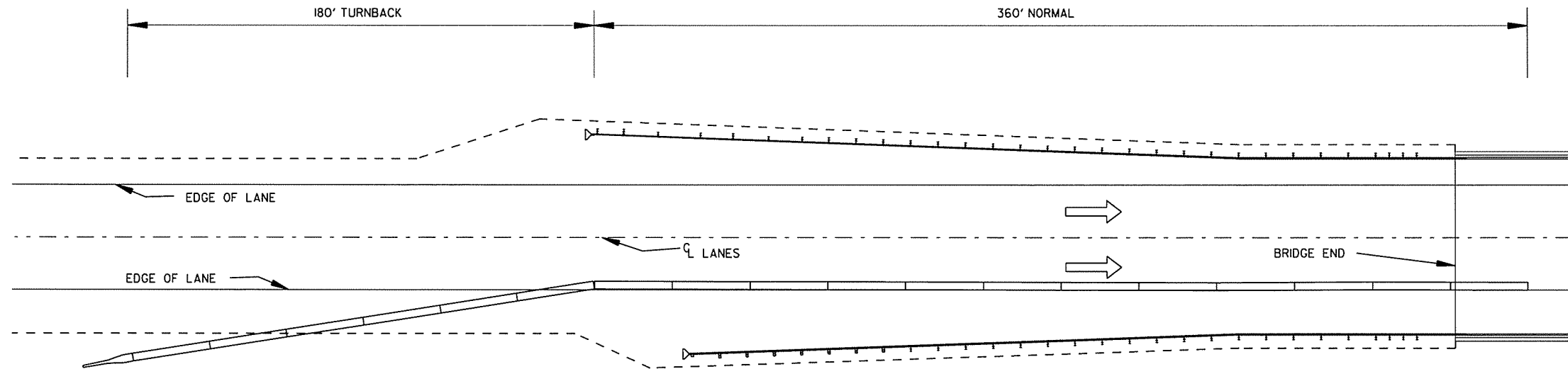

LAYOUT OF PRECAST CONCRETE BARRIER FOR RIGHT APPROACH GUTTER

TYPICAL LAYOUT OF PRECAST BARRIER FOR APPROACH GUTTER RECONSTRUCTION



DATE REVISED	DATE FILMED	DATE REVISED	DATE FILMED	FED. RD. DIST. NO.	STATE	FED. AID PROJ. NO.	SHEET NO.	TOTAL SHEETS	
				6	ARK.				
JOB NO.							012196	41	88

MAINTENANCE OF TRAFFIC

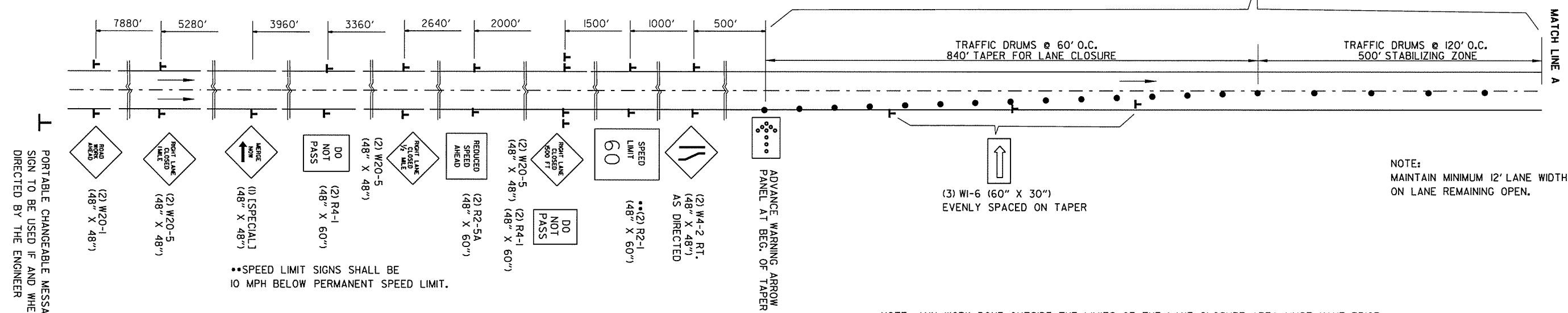

RT. LANE CLOSURE

PORTABLE CHANGEABLE MESSAGE SIGN TO BE USED IF AND WHERE DIRECTED BY THE ENGINEER

•SPEED LIMIT SIGNS SHALL BE 10 MPH BELOW PERMANENT SPEED LIMIT.

NOTE: ANY WORK DONE OUTSIDE THE LIMITS OF THE LANE CLOSURE AREA MUST HAVE PRIOR WRITTEN APPROVAL OF THE ENGINEER AND ANY ADDITIONAL TRAFFIC CONTROL DEVICES REQUIRED SHALL BE PROVIDED AT NO ADDITIONAL COST TO THE DEPARTMENT.

NOTE: MAINTAIN MINIMUM 12' LANE WIDTH ON LANE REMAINING OPEN.

•SPEED LIMIT SIGNS SHALL BE 10 MPH BELOW PERMANENT SPEED LIMIT.

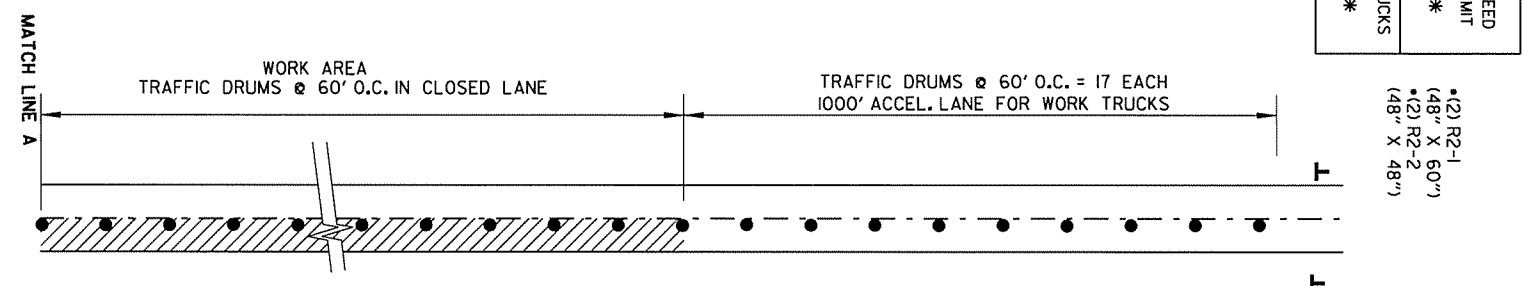

DIVERSION FOR RT. LANE WORK ZONE

• SPEED LIMIT SHALL MATCH PERMANENT SPEED LIMIT. (SEE WORK AREAS SHEETS FOR FURTHER INFORMATION)

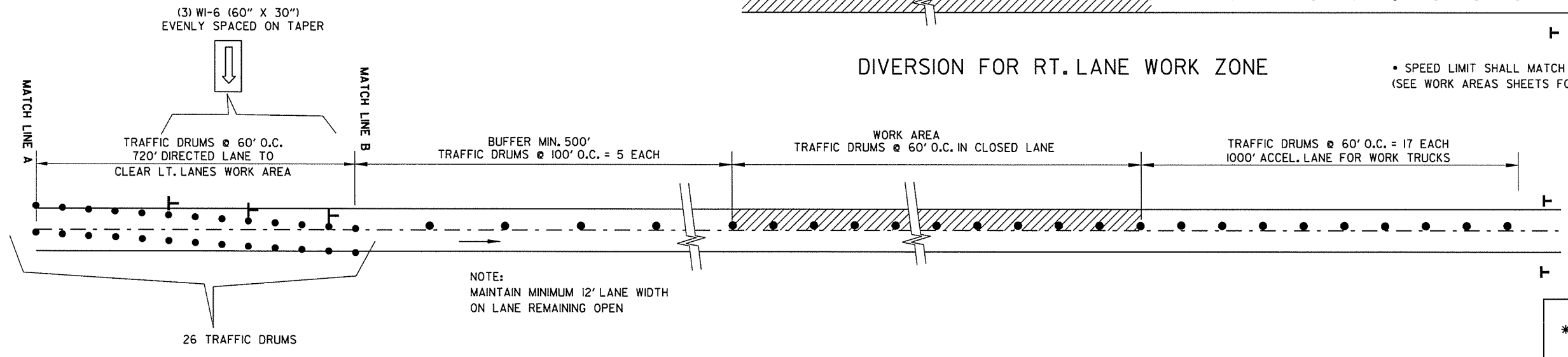

DIVERSION FOR LT. LANE WORK ZONE

NOTE: REFER TO SP-MAINTENANCE OF TRAFFIC FOR LANE CLOSURE LIMITATIONS AND RESTRICTIONS. QUANTITY OF TRAFFIC DRUMS PROVIDED IN THE CONTRACT IS THE MAXIMUM NUMBER REQUIRED FOR ONE LANE CLOSURE.

NOTE: CONTRACTOR MUST UTILIZE ENTRY/EXIT LOCATION AS SHOWN ON THE PLANS.

MAINTENANCE OF TRAFFIC LANE CLOSURES



DATE REVISED	DATE FILMED	DATE REVISED	DATE FILMED	FED. RD. DIST. NO.	STATE	FED. AID PROJ. NO.	SHEET NO.	TOTAL SHEETS
				6	ARK.			
JOB NO. 012196							42	88
MAINTENANCE OF TRAFFIC								

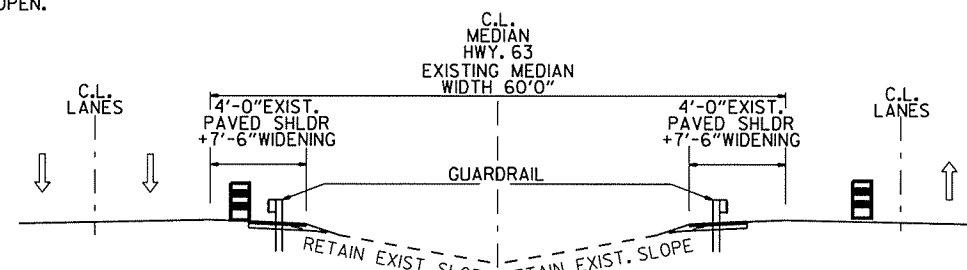
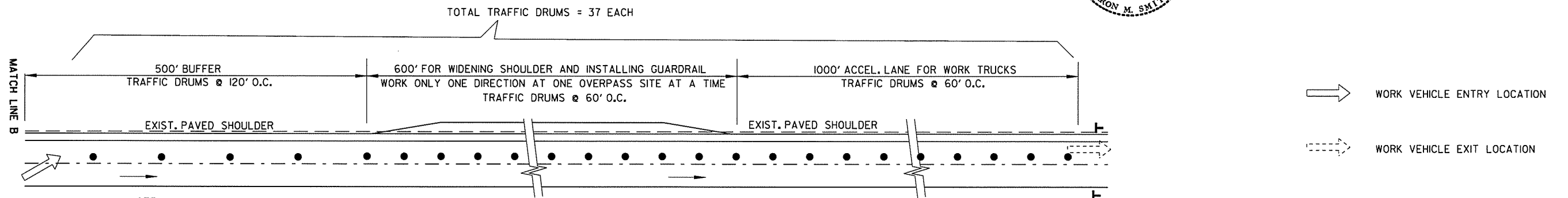

TRUCKS
65

SPEED LIMIT
70

(2) R2-2
(48" X 48")

(2) R2-1
(48" X 60")

MOVABLE WORK ZONE FOR GUARDRAIL INSTALLATION

NOTE: REFER TO SP-MAINTENANCE OF TRAFFIC FOR LANE CLOSURE LIMITATIONS AND RESTRICTIONS. QUANTITY OF TRAFFIC DRUMS PROVIDED IN THE CONTRACT IS THE MAXIMUM NUMBER REQUIRED FOR ONE LANE CLOSURE.

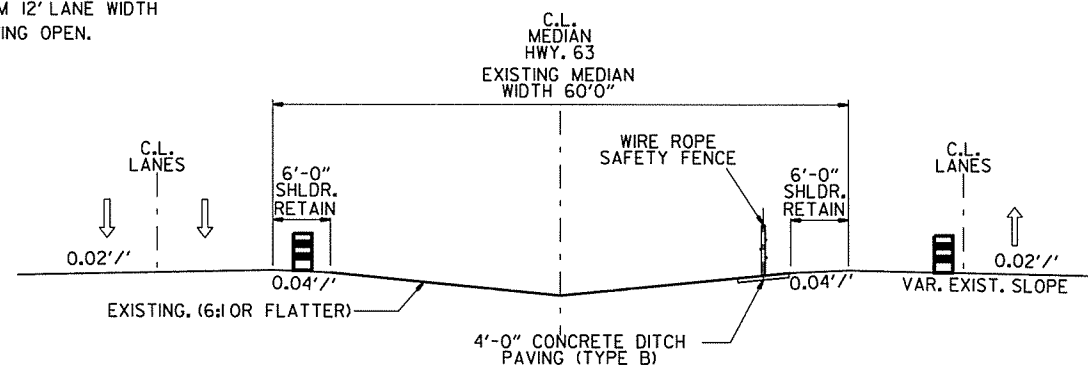
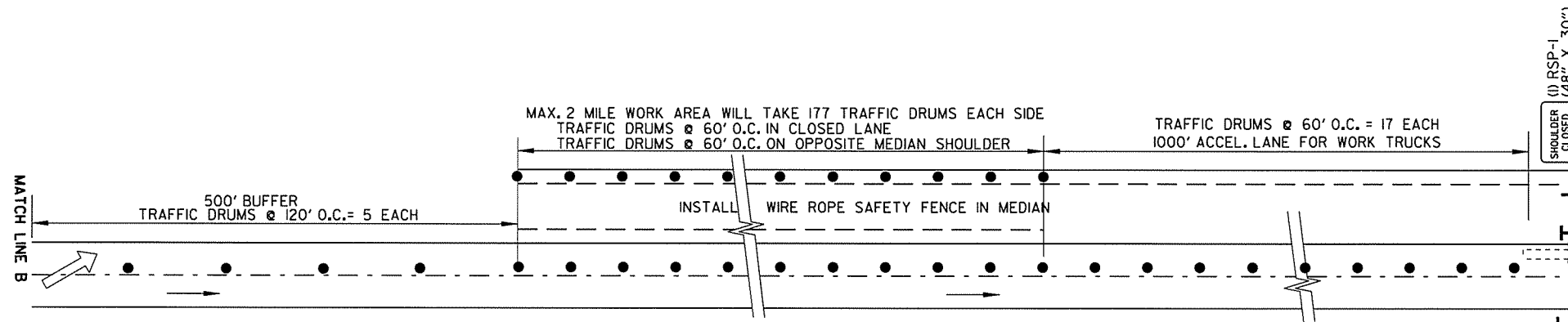

TRUCKS
65

SPEED LIMIT
70

(2) R2-2
(48" X 48")

(2) R2-1
(48" X 60")

•SPEED LIMIT SIGNS SHALL MATCH PERMANENT SPEED LIMIT.

MOVABLE WORK ZONE FOR WRSF INSTALLATION

NOTE: CONTRACTOR MUST UTILIZE ENTRY/EXIT LOCATION AS SHOWN ON THE PLANS.

MAINTENANCE OF TRAFFIC WORK AREAS

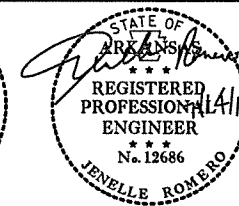

DATE REVISED	DATE FILMED	DATE REVISED	DATE FILMED	FED. RD. DIST. NO.	STATE	FED. AID PROJ. NO.	SHEET NO.	TOTAL SHEETS
				6	ARK.			
				JOB NO.		02196	43	88

EROSION CONTROL

LOCATION	TEMPORARY EROSION CONTROL						PERMANENT EROSION CONTROL				
	TEMPORARY SEEDING	MULCH COVER	WATER	SAND BAG DITCH CHECKS (E-5)	DROP INLET SILT FENCE (E-7)	SEDIMENT REMOVAL AND DISPOSAL	SEEDING	LIME	MULCH COVER	SECOND SEEDING APPLICATION	WATER
	ACRE	ACRE	M.GAL.	BAG	LIN.FT.	C.Y.	ACRE	TON	ACRE	ACRE	M.GAL.
ENTIRE JOB	52.05	52.05	1061.8	5320	4410	433.65	52.05	104.11	52.05	52.05	5309.1
ENTIRE PROJECT IF AND WHERE DIRECTED BY THE ENGINEER				60	60						
TOTALS:	52.05	52.05	1061.8	5380	4470	433.65	52.05	104.11	52.05	52.05	5309.1

RESPONSIBLE FOR QUANTITIES IN EROSION CONTROL AND ADVANCE WARNING SIGNS AND DEVICES TABLES

RESPONSIBLE FOR ALL OTHER QUANTITIES

BASIS OF ESTIMATE:

- LIME.....2 TONS/ACRE OF SEEDING
- WATER.....102.0 M.G./ACRE OF SEEDING
- WATER.....20.4 M.G./ACRE OF TEMPORARY SEEDING
- DROP INLET SILT FENCES.....30 LIN.FT./LOCATION
- SAND BAG DITCH CHECKS.....20 BAGS/LOCATION

NOTE: THE TEMPORARY EROSION CONTROL DEVICES SHOWN ABOVE AND ON THE PLANS SHALL BE INSTALLED IN SUCH A SEQUENCE AS TO DETER EROSION AND SEDIMENTATION OF U.S. WATERWAYS AS EXPLAINED BY THE NATIONAL POLLUTANT DISCHARGE ELIMINATION SYSTEM PERMIT.

ADVANCE WARNING SIGNS AND DEVICES

SIGN NUMBER	DESCRIPTION	SIGN SIZE	MAXIMUM NUMBER REQUIRED	TOTAL SIGNS REQUIRED		TRAFFIC DRUMS	FURNISHING & INSTALLING PRECAST CONCRETE	RELOCATING PRECAST CONCRETE BARRIER	ADVANCE WARNING ARROW PANEL	PORTABLE CHANGEABLE MESSAGE SIGN
			SQ.FT-LIN.FT.-EA	NO.	SQ. FT.					
W20-1	ROAD WORK 1 MILE	48"X48"	16	4	64					
W20-1	ROAD WORK 1/2 MILE	48"X48"	16	4	64					
W20-1	ROAD WORK 1500 FT.	48"X48"	16	4	64					
W20-1	ROAD WORK AHEAD	48"X48"	16	24	384					
G20-1	ROAD WORK NEXT xx MILES	60"X24"	6	2	12					
G20-2	END ROAD WORK	48"X24"	8	4	32					
SPECIAL 1	MERGE NOW + ARROW	48"X48"	16	1	16					
W20-5	RIGHT LANE CLOSED 1 MILE	48"X48"	16	2	32					
W20-5	RIGHT LANE CLOSED 1/2 MILE	48"X48"	16	2	32					
W20-5	RIGHT LANE CLOSED 1500 FT.	48"X48"	16	2	32					
W4-2R	RIGHT LANE CLOSING GRAPHIC	48"X48"	16	2	32					
W1-6	LARGER ARROW	60"X30"	12.5	6	75					
R4-1	DO NOT PASS	48"X60"	20	4	80					
R55-1	FINES DOUBLE IN WORK ZONES	36"X60"	15	4	60					
R2-5A	REDUCED SPEED AHEAD	48"X60"	20	2	40					
R2-1	SPEED LIMIT 60 MPH	48"X60"	20	2	40					
R2-1	SPEED LIMIT 70 MPH	48"X60"	20	2	40					
R2-2	TRUCKS 65	48"X60"	20	2	40					
RSP-1	SHOULDER CLOSED	48"X30"	10	3	30					
	PORTABLE CONCRETE BARRIERS						2765	8295		
	TRAFFIC DRUMS		421			421				
	ADVANCE WARNING ARROW PANEL		1					120		
	PORTABLE CHANGEABLE MESSAGE SIGN		2						86	
TOTALS:					1169	421	2765	8295	120	86

NOTE: THIS IS A HIGH VOLUME ROAD AS DEFINED IN SECTION 604.03 OF THE STANDARD SPECIFICATIONS FOR HIGHWAY CONSTRUCTION, EDITION OF 2014.

REMOVAL AND DISPOSAL ITEMS

STATION	DESCRIPTION	IMPACT ATTENUATION BARRIER
		EACH
81+05	ON CENTERLINE OF MEDIAN	2
358+29	ON CENTERLINE OF MEDIAN	2
436+77	ON CENTERLINE OF MEDIAN	2
79+00	ON CENTERLINE OF MEDIAN	2
95+00	ON CENTERLINE OF MEDIAN	2
495+64	ON CENTERLINE OF MEDIAN	2
555+72	ON CENTERLINE OF MEDIAN	2
780+64	ON CENTERLINE OF MEDIAN	2
926+39	ON CENTERLINE OF MEDIAN	2
1061+41	ON CENTERLINE OF MEDIAN	2
TOTAL:		20

QUANTITIES

7/17/2014 10:25 AM P:\100038109\CADD\GEN\63sumtbl.dgn

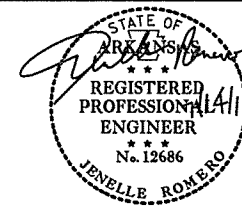

DATE REVISED	DATE FILMED	DATE REVISED	DATE FILMED	FED. RD. DIST. NO.	STATE	FED. AID PROJ. NO.	SHEET NO.	TOTAL SHEETS
				6	ARK.			
				JOB NO.		012196	44	88

CONCRETE DITCH PAVING

STATION	STATION	STATION EQUATION	LOCATION	LENGTH	WDTH	CONC. DITCH PAVING (TYPE B)	SOLID SODDING	WATER
				FEET	FEET	SQ. YD.	M. GAL.	
122+25.00	151+32.00		RT. OF CL HWY. 63	2907	4	1292	1292	16.3
45+60.00	77+33.00		RT. OF CL HWY. 63	3173	4	1410	1410	17.8
82+68.00	181+18.00		RT. OF CL HWY. 63	9850	4	4378	4378	55.2
182+08.00	208+08.00		LT. OF CL HWY. 63	2600	4	1156	1156	14.6
211+04.00	356+66.00		LT. OF CL HWY. 63	14562	4	6472	6472	81.5
359+93.00	401+21.00		RT. OF CL HWY. 63	4128	4	1835	1835	23.1
406+81.00	407+78.75	BK.	LT. OF CL HWY. 63	98	4	44	44	0.6
409+78.93	434+98.00	AHD.	LT. OF CL HWY. 63	2519	4	1120	1120	14.1
438+59.00	461+00.00	BK.	RT. OF CL HWY. 63	2241	4	996	996	12.5
458+75.27	543+53.00	AHD.	RT. OF CL HWY. 63	8478	4	3768	3768	47.5
548+42.00	551+98.00		RT. OF CL HWY. 63	356	4	158	158	2.0
552+88.00	564+60.00		LT. OF CL HWY. 63	1172	4	521	521	6.6
70+65.00	78+33.00		CL MEDIAN OF HWY. 63	768	4	341	341	4.3
79+68.00	94+33.00		CL MEDIAN OF HWY. 63	1465	4	651	651	8.2
95+69.00	102+92.04	BK.	CL MEDIAN OF HWY. 63	723	4	321	321	4.0
101+96.76	158+09.00	AHD.	CL MEDIAN OF HWY. 63	5612	4	2494	2494	31.4
162+90.00	196+55.00		CL MEDIAN OF HWY. 63	3365	4	1496	1496	18.8
197+45.00	350+05.00		CL MEDIAN OF HWY. 63	15260	4	6782	6782	85.5
350+95.00	360+31.00		CL MEDIAN OF HWY. 63	936	4	416	416	5.2
365+71.00	400+93.00		CL MEDIAN OF HWY. 63	3522	4	1565	1565	19.7
406+80.00	449+55.00		CL MEDIAN OF HWY. 63	4275	4	1900	1900	23.9
450+45.00	482+35.00		CL MEDIAN OF HWY. 63	3190	4	1418	1418	17.9
496+38.00	537+55.00		CL MEDIAN OF HWY. 63	4117	4	1830	1830	23.1
538+45.00	554+97.00		CL MEDIAN OF HWY. 63	1652	4	734	734	9.2
556+46.00	662+93.00		CL MEDIAN OF HWY. 63	10647	4	4732	4732	59.6
668+18.00	765+55.00		CL MEDIAN OF HWY. 63	9737	4	4328	4328	54.5
766+45.00	779+93.00		CL MEDIAN OF HWY. 63	1348	4	599	599	7.5
781+36.00	811+32.00		CL MEDIAN OF HWY. 63	2996	4	1332	1332	16.8
816+13.00	925+63.00		CL MEDIAN OF HWY. 63	10950	4	4867	4867	61.3
927+15.00	977+50.00		CL MEDIAN OF HWY. 63	5035	4	2238	2238	28.2
985+81.00	1060+65.00		CL MEDIAN OF HWY. 63	7484	4	3326	3326	41.9
1062+17.00	1084+01.00		CL MEDIAN OF HWY. 63	2184	4	971	971	12.2
1088+54.00	1112+55.00		CL MEDIAN OF HWY. 63	2401	4	1067	1067	13.4
1113+45.00	1171+15.00		CL MEDIAN OF HWY. 63	5770	4	2564	2564	32.3
1170+65.00	1210+85.00		LT. OF CL HWY. 63	4020	4	1787	1787	22.5
TOTALS:						70909	70909	893.2

BASIS OF ESTIMATE:
 WATER.....12.6 GAL. / SQ. YD. OF SOLID SODDING.

WIRE ROPE SAFETY FENCE

STATION	STATION	STATION EQUATION	LOCATION	WIRE ROPE SAFETY FENCE	◇ WRSF ANCHOR	WRSF MAINTENANCE MATERIALS	WRSF POST REPAIR
				LIN. FT.	EACH	LUMP SUM	EACH
122+25.00	151+32.00		RT. OF CL HWY. 63	2907	2		
45+60.00	77+33.00		RT. OF CL HWY. 63	3173	2		
82+08.00	181+18.00		RT. OF CL HWY. 63	9910	2		
182+08.00	208+08.00		LT. OF CL HWY. 63	2600	2		
211+04.00	357+26.00		LT. OF CL HWY. 63	14622	2		
359+33.00	401+21.00		RT. OF CL HWY. 63	4188	2		
406+81.00	407+78.75	BK.	LT. OF CL HWY. 63	98	1		
409+78.93	435+58.00	AHD.	LT. OF CL HWY. 63	2579	1		
437+99.00	461+00.00	BK.	RT. OF CL HWY. 63	2301	1		
458+75.27	543+53.00	AHD.	RT. OF CL HWY. 63	8478	1		
548+42.00	551+98.00		RT. OF CL HWY. 63	356	2		
552+88.00	564+60.00		LT. OF CL HWY. 63	1172	2		
70+65.00	78+33.00		CL MEDIAN OF HWY. 63	768	2		
79+68.00	94+33.00		CL MEDIAN OF HWY. 63	1465	2		
95+69.00	102+92.04	BK.	CL MEDIAN OF HWY. 63	723	1		
101+96.76	158+09.00	AHD.	CL MEDIAN OF HWY. 63	5612	1		
162+90.00	196+55.00		CL MEDIAN OF HWY. 63	3365	2		
197+45.00	350+05.00		CL MEDIAN OF HWY. 63	15260	2		
350+95.00	360+31.00		CL MEDIAN OF HWY. 63	936	2		
365+71.00	400+93.00		CL MEDIAN OF HWY. 63	3522	2		
406+80.00	449+55.00		CL MEDIAN OF HWY. 63	4275	2		
450+45.00	482+35.00		CL MEDIAN OF HWY. 63	3190	2		
496+38.00	537+55.00		CL MEDIAN OF HWY. 63	4117	2		
538+45.00	554+97.00		CL MEDIAN OF HWY. 63	1652	2		
556+46.00	662+93.00		CL MEDIAN OF HWY. 63	10647	2		
668+18.00	765+55.00		CL MEDIAN OF HWY. 63	9737	2		
766+45.00	779+93.00		CL MEDIAN OF HWY. 63	1348	2		
781+36.00	811+32.00		CL MEDIAN OF HWY. 63	2996	2		
816+13.00	925+63.00		CL MEDIAN OF HWY. 63	10950	2		
927+15.00	977+50.00		CL MEDIAN OF HWY. 63	5035	2		
985+81.00	1060+65.00		CL MEDIAN OF HWY. 63	7484	2		
1062+17.00	1084+01.00		CL MEDIAN OF HWY. 63	2184	2		
1088+54.00	1112+55.00		CL MEDIAN OF HWY. 63	2401	2		
1113+45.00	1171+15.00		CL MEDIAN OF HWY. 63	5770	2		
1170+65.00	1210+85.00		CL MEDIAN OF HWY. 63	4020	2		
TOTALS:				159841	64	1.00	50

◇ THIS ITEM SHOWN FOR INFORMATION ONLY
 * QUANTITY IS ESTIMATED.
 SEE SECTION 104.03 OF THE STANDARD SPECIFICATIONS.

QUANTITIES

17/11/2014 10:23:34 AM P:\00038109\CAADD\GEN\6_3sum02.dwg

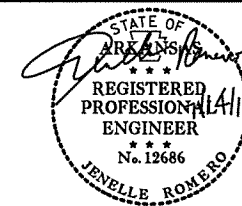

DATE REVISED	DATE FILMED	DATE REVISED	DATE FILMED	FED. RD. DIST. NO.	STATE	FED. AID PROJ. NO.	SHEET NO.	TOTAL SHEETS
				6	ARK.			
				JOB NO.		02196	45	88

QUANTITIES

BASE AND SURFACING

STATION	STATION	LOCATION	LENGTH FEET	AGGREGATE BASE COURSE (CLASS 7)		ACHM SURFACE COURSE (1/2") (PG 64-22)			
				TON / STATION	TON	AVG. WID. FEET	SQ. YD.	POUND / SQ. YD.	TON
76+25.00	83+16.00	RT. SHLDR. AT HWY. 77 OVERPASS	691.00	44.75	309.22	8.17	627.27	220.00	69.00
79+08.00	85+69.00	LT. SHLDR. AT HWY. 77 OVERPASS	661.00	35.00	231.35	7.50	550.83	220.00	60.59
353+65.00	360+41.00	RT. SHLDR. AT HWY. 135 OVERPASS	676.00	37.00	250.12	7.71	579.11	220.00	63.70
356+18.00	362+94.00	LT. SHLDR. AT HWY. 135 OVERPASS	676.00	37.00	250.12	7.71	579.11	220.00	63.70
432+05.00	439+06.00	RT. SHLDR. AT HWY. 118 OVERPASS	701.00	37.00	259.37	7.61	592.73	220.00	65.20
434+50.00	441+50.00	LT. SHLDR. AT HWY. 118 OVERPASS	700.00	37.00	259.00	7.79	605.89	220.00	66.65
64+09.00	67+55.00	OUTSIDE SHLDR. OF SB LANES AT DITCH #103	346.00	44.75	154.84	9.72	373.60	220.00	41.10
64+09.00	67+55.00	OUTSIDE SHLDR. OF NB LANES AT DITCH #35	346.00	44.75	154.84	9.72	373.60	220.00	41.10
69+02.00	72+47.00	OUTSIDE SHLDR. OF SB LANES AT DITCH #103	345.00	44.75	154.39	9.20	352.75	220.00	38.80
69+03.00	73+04.00	INSIDE SHLDR. OF SB LANES AT DITCH #103	401.00	44.75	179.45	10.19	453.81	220.00	49.92
74+60.00	80+97.00	RT. SHLDR. AT COTTONWOOD RD. OVERPASS	637.00	35.00	222.95	7.50	530.83	220.00	58.39
77+05.00	83+41.00	LT. SHLDR. AT COTTONWOOD RD. OVERPASS	636.00	35.00	222.60	7.50	530.00	220.00	58.30
90+60.00	96+97.00	RT. SHLDR. AT HWY. 14 OVERPASS	637.00	35.00	222.95	7.50	530.83	220.00	58.39
93+05.00	99+41.00	LT. SHLDR. AT HWY. 14 OVERPASS	636.00	35.00	222.60	7.50	530.00	220.00	58.30
155+77.00	159+81.00	INSIDE SHLDR. OF NB LANES AT CO. RD. 269	404.00	44.75	180.79	10.08	452.67	220.00	49.79
156+36.00	159+81.00	OUTSIDE SHLDR. OF NB LANES AT CO. RD. 269	345.00	44.75	154.39	9.02	345.59	220.00	38.01
161+18.00	164+63.00	OUTSIDE SHLDR. OF SB LANES AT CO. RD. 269	345.00	44.75	154.39	9.02	345.59	220.00	38.01
161+18.00	165+22.00	INSIDE SHLDR. OF SB LANES AT CO. RD. 269	404.00	44.75	180.79	10.08	452.67	220.00	49.79
357+99.00	362+03.00	INSIDE SHLDR. OF NB LANES AT CO. RD. 226	404.00	44.75	180.79	10.08	452.67	220.00	49.79
358+58.00	362+03.00	OUTSIDE SHLDR. OF NB LANES AT CO. RD. 226	345.00	44.75	154.39	9.02	345.59	220.00	38.01
363+99.00	367+44.00	OUTSIDE SHLDR. OF SB LANES AT CO. RD. 226	345.00	44.75	154.39	9.02	345.59	220.00	38.01
363+99.00	368+03.00	INSIDE SHLDR. OF SB LANES AT CO. RD. 226	404.00	44.75	180.79	10.08	452.67	220.00	49.79
478+46.00 (BK)	497+66.00 (AHD)	RT. SHLDR. AT CO. RD. 231 OVERPASS	636.00	35.00	222.60	7.50	530.00	220.00	58.30
481+07.00 (BK)	499+97.00 (AHD)	LT. SHLDR. AT CO. RD. 231 OVERPASS	636.00	35.00	222.60	7.50	530.00	220.00	58.30
551+38.00	557+74.00	RT. SHLDR. AT CO. RD. 230 OVERPASS	636.00	35.00	222.60	7.50	530.00	220.00	58.30
553+69.00	560+05.00	LT. SHLDR. AT CO. RD. 230 OVERPASS	636.00	35.00	222.60	7.50	530.00	220.00	58.30
776+28.00	782+64.00	RT. SHLDR. AT CO. RD. 652 OVERPASS	636.00	35.00	222.60	7.50	530.00	220.00	58.30
778+65.00	785+01.00	LT. SHLDR. AT CO. RD. 652 OVERPASS	636.00	35.00	222.60	7.50	530.00	220.00	58.30
922+07.00	928+43.00	RT. SHLDR. AT CO. RD. 638 OVERPASS	636.00	35.00	222.60	7.50	530.00	220.00	58.30
924+35.00	930+71.00	LT. SHLDR. AT CO. RD. 638 OVERPASS	636.00	35.00	222.60	7.50	530.00	220.00	58.30
975+17.00	979+21.00	INSIDE SHLDR. OF NB LANES AT HWY. 463	404.00	44.75	180.79	10.10	453.59	220.00	49.89
975+43.00	978+88.00	OUTSIDE SHLDR. OF NB LANES AT HWY. 463	345.00	44.75	154.39	8.99	344.67	220.00	37.91
984+10.00	988+14.00	INSIDE SHLDR. OF SB LANES AT HWY. 463	404.00	44.75	180.79	10.08	452.67	220.00	49.79
984+43.00	987+88.00	OUTSIDE SHLDR. OF SB LANES AT HWY. 463	345.00	44.75	154.39	9.02	345.59	220.00	38.01
1057+09.00	1063+45.00	RT. SHLDR. AT GUM POINT RD. OVERPASS	636.00	35.00	222.60	7.50	530.00	220.00	58.30
1059+37.00	1065+73.00	LT. SHLDR. AT GUM POINT RD. OVERPASS	636.00	35.00	222.60	7.50	530.00	220.00	58.30
1081+70.00	1085+74.00	INSIDE SHLDR. OF NB LANES AT LITTLE BAY DITCH	404.00	44.75	180.79	10.08	452.67	220.00	49.79
1082+63.00	1086+07.00	OUTSIDE SHLDR. OF NB LANES AT LITTLE BAY DITCH	344.00	44.75	153.94	9.04	345.59	220.00	38.01
1086+48.00	1089+92.00	OUTSIDE SHLDR. OF SB LANES AT LITTLE BAY DITCH	344.00	44.75	153.94	9.04	345.59	220.00	38.01
1086+81.00	1090+84.00	INSIDE SHLDR. OF SB LANES AT LITTLE BAY DITCH	403.00	44.75	180.34	10.11	452.67	220.00	49.79
TOTALS:					7999.89		18896.44		2078.54

BASIS OF ESTIMATE:
 110 LBS. PER SQ. YD. PER INCH DEPTH
 ACHM SURFACE COURSE (1/2").....94.8% MIN. AGGR.....5.2% ASPHALT BINDER
 MAXIMUM NUMBER OF GYRATIONS = 115

GUARDRAIL

STATION	STATION	LOCATION	GUARDRAIL	TERMINAL ANCHOR POST	GUARDRAIL TERMINAL	THRIE BEAM GUARDRAIL TERMINAL
			(TYPE A)	(TYPE 1)	(TYPE 2)	
			LIN. FT.	EACH		
76+83	82+58	RT. SHLDR. AT HWY. 77 OVERPASS	525	1	1	
79+51	85+26	LT. SHLDR. AT HWY. 77 OVERPASS	525	1	1	
354+08	359+83	RT. SHLDR. AT HWY. 135 OVERPASS	525	1	1	
356+76	362+51	LT. SHLDR. AT HWY. 135 OVERPASS	525	1	1	
432+48	438+48	RT. SHLDR. AT HWY. 118 OVERPASS	550	1	1	
435+08	441+08	LT. SHLDR. AT HWY. 118 OVERPASS	550	1	1	
64+86	67+36	OUTSIDE SHLDR. OF SB LANES AT DITCH #103	200			1
64+86	67+36	OUTSIDE SHLDR. OF NB LANES AT DITCH #35	200			1
69+22	71+72	OUTSIDE SHLDR. OF SB LANES AT DITCH #103	200			1
69+22	72+22	INSIDE SHLDR. OF SB LANES AT DITCH #103	250			1
75+03	80+53	RT. SHLDR. AT COTTONWOOD RD. OVERPASS	500	1	1	
77+48	82+98	LT. SHLDR. AT COTTONWOOD RD. OVERPASS	500	1	1	
91+03	96+53	RT. SHLDR. AT HWY. 14 OVERPASS	500	1	1	
93+48	98+98	LT. SHLDR. AT HWY. 14 OVERPASS	500	1	1	
155+99	158+99	INSIDE SHLDR. OF NB LANES AT CO. RD. 269	250			1
156+49	158+99	OUTSIDE SHLDR. OF NB LANES AT CO. RD. 269	200			1
161+37	163+87	OUTSIDE SHLDR. OF SB LANES AT CO. RD. 269	200			1
161+37	164+37	INSIDE SHLDR. OF SB LANES AT CO. RD. 269	250			1
358+84	361+84	INSIDE SHLDR. OF NB LANES AT CO. RD. 226	250			1
359+34	361+84	OUTSIDE SHLDR. OF NB LANES AT CO. RD. 226	200			1
364+18	366+68	OUTSIDE SHLDR. OF SB LANES AT CO. RD. 226	200			1
364+18	367+18	INSIDE SHLDR. OF SB LANES AT CO. RD. 226	250			1
479+19 (BK)	497+23 (AHD)	RT. SHLDR. AT CO. RD. 231 OVERPASS	500	1	1	
481+50 (BK)	499+54 (AHD)	LT. SHLDR. AT CO. RD. 231 OVERPASS	500	1	1	
551+81	557+31	RT. SHLDR. AT CO. RD. 230 OVERPASS	500	1	1	
554+12	559+62	LT. SHLDR. AT CO. RD. 230 OVERPASS	500	1	1	
776+71	782+21	RT. SHLDR. AT CO. RD. 652 OVERPASS	500	1	1	
779+08	784+58	LT. SHLDR. AT CO. RD. 652 OVERPASS	500	1	1	
922+50	928+00	RT. SHLDR. AT CO. RD. 638 OVERPASS	500	1	1	
924+78	930+28	LT. SHLDR. AT CO. RD. 638 OVERPASS	500	1	1	
976+02	979+02	INSIDE SHLDR. OF NB LANES AT HWY. 463	250			1
978+69	981+19	OUTSIDE SHLDR. OF NB LANES AT HWY. 463	200			1
984+29	987+29	INSIDE SHLDR. OF SB LANES AT HWY. 463	250			1
984+62	987+12	OUTSIDE SHLDR. OF SB LANES AT HWY. 463	200			1
1057+52	1063+02	RT. SHLDR. AT GUM POINT RD. OVERPASS	500	1	1	
1059+80	1065+30	LT. SHLDR. AT GUM POINT RD. OVERPASS	500	1	1	
1082+55	1085+55	INSIDE SHLDR. OF NB LANES AT LITTLE BAY DITCH	250			1
1083+38	1085+88	OUTSIDE SHLDR. OF NB LANES AT LITTLE BAY DITCH	200			1
1086+67	1089+17	OUTSIDE SHLDR. OF SB LANES AT LITTLE BAY DITCH	200			1
1087+00	1090+00	INSIDE SHLDR. OF SB LANES AT LITTLE BAY DITCH	250			1
TOTALS:			14650	20	40	20

QUANTITIES

11/2/2014 11:02:40 AM P:\00038109\CADD\GEN\63sum03.dgn

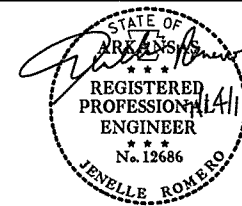

DATE REVISED	DATE FILMED	DATE REVISED	DATE FILMED	FED. RD. DIST. NO.	STATE	FED. AID PROJ. NO.	SHEET NO.	TOTAL SHEETS
				6	ARK.			
				JOB NO.		012196	46	88

QUANTITIES

EARTHWORK

STATION	STATION	LOCATION	UNCLASSIFIED EXCAVATION	COMPACTED EMBANKMENT
			CU. YD.	
76+25	83+16	RT. SHLDR. AT HWY. 77 OVERPASS	90	68
79+08	85+69	LT. SHLDR. AT HWY. 77 OVERPASS	86	65
353+65	360+41	RT. SHLDR. AT HWY. 135 OVERPASS	88	67
356+18	362+94	LT. SHLDR. AT HWY. 135 OVERPASS	88	67
432+05	439+06	RT. SHLDR. AT HWY. 118 OVERPASS	91	69
434+50	441+50	LT. SHLDR. AT HWY. 118 OVERPASS	91	69
64+09	67+55	OUTSIDE SHLDR. OF SB LANES AT DITCH #103	45	9
64+09	67+55	OUTSIDE SHLDR. OF NB LANES AT DITCH #35	45	9
69+03	72+34	OUTSIDE SHLDR. OF SB LANES AT DITCH #103	43	9
69+03	73+04	INSIDE SHLDR. OF SB LANES AT DITCH #103	52	11
74+60	80+97	RT. SHLDR. AT COTTONWOOD RD. OVERPASS	83	17
77+05	83+41	LT. SHLDR. AT COTTONWOOD RD. OVERPASS	82	17
90+60	96+97	RT. SHLDR. AT HWY. 14 OVERPASS	83	17
93+05	99+41	LT. SHLDR. AT HWY. 14 OVERPASS	82	17
155+77	159+81	INSIDE SHLDR. OF NB LANES AT CO. RD. 269	52	11
156+36	159+81	OUTSIDE SHLDR. OF NB LANES AT CO. RD. 269	45	9
161+18	164+63	OUTSIDE SHLDR. OF SB LANES AT CO. RD. 269	45	9
161+18	165+22	INSIDE SHLDR. OF SB LANES AT CO. RD. 269	52	11
357+99	362+03	INSIDE SHLDR. OF NB LANES AT CO. RD. 226	52	11
358+58	362+03	OUTSIDE SHLDR. OF NB LANES AT CO. RD. 226	45	9
363+99	367+44	OUTSIDE SHLDR. OF SB LANES AT CO. RD. 226	45	9
363+99	368+03	INSIDE SHLDR. OF SB LANES AT CO. RD. 226	52	11
478+76 (BK)	497+66 (AHD.)	RT. SHLDR. AT CO. RD. 231 OVERPASS	82	17
481+07 (BK)	499+97 (AHD.)	LT. SHLDR. AT CO. RD. 231 OVERPASS	82	17
551+38	557+74	RT. SHLDR. AT CO. RD. 230 OVERPASS	82	17
553+69	560+05	LT. SHLDR. AT CO. RD. 230 OVERPASS	82	17
776+28	782+64	RT. SHLDR. AT CO. RD. 652 OVERPASS	82	17
778+65	785+01	LT. SHLDR. AT CO. RD. 652 OVERPASS	82	17
922+07	928+43	RT. SHLDR. AT CO. RD. 638 OVERPASS	82	17
924+35	930+71	LT. SHLDR. AT CO. RD. 638 OVERPASS	82	17
975+17	979+21	INSIDE SHLDR. OF NB LANES AT HWY. 463	52	11
975+43	978+88	OUTSIDE SHLDR. OF NB LANES AT HWY. 463	45	9
984+10	988+14	INSIDE SHLDR. OF SB LANES AT HWY. 463	52	11
984+43	987+88	OUTSIDE SHLDR. OF SB LANES AT HWY. 463	45	9
1057+09	1063+45	RT. SHLDR. AT GUM POINT RD. OVERPASS	82	17
1059+37	1065+73	LT. SHLDR. AT GUM POINT RD. OVERPASS	82	17
1081+70	1085+74	INSIDE SHLDR. OF NB LANES AT LITTLE BAY DITCH	52	11
1082+63	1086+07	OUTSIDE SHLDR. OF NB LANES AT LITTLE BAY DITCH	45	9
1086+48	1089+92	OUTSIDE SHLDR. OF SB LANES AT LITTLE BAY DITCH	45	9
1086+81	1090+84	INSIDE SHLDR. OF SB LANES AT LITTLE BAY DITCH	52	11
TOTALS:			2645	841

NOTE: EARTHWORK QUANTITIES SHOWN ABOVE SHALL BE PAID FOR AS PLAN QUANTITY.

APPROACH GUTTERS

STATION	LOCATION	APPROACH GUTTERS (TYPE 'PT')	REINFORCING STEEL - RDWY. (GRADE 60)
		CU. YD.	LB.
67+55	SB LANES AT DITCH #103 (OUTSIDE SHLDR.)	20.07	1815
67+55	NB LANES AT DITCH #35 (OUTSIDE SHLDR.)	20.07	1815
69+03	SB LANES AT DITCH #103 (OUTSIDE SHLDR.)	20.07	1815
69+03	SB LANES AT DITCH #103 (INSIDE SHLDR.)	13.34	1296
159+81	NB LANES AT CO. RD. 269 (INSIDE SHLDR.)	13.34	1296
159+81	NB LANES AT CO. RD. 269 (OUTSIDE SHLDR.)	20.07	1815
161+18	SB LANES AT CO. RD. 269 (OUTSIDE SHLDR.)	20.07	1815
161+18	SB LANES AT CO. RD. 269 (INSIDE SHLDR.)	13.34	1296
362+03	NB LANES AT CO. RD. 226 (INSIDE SHLDR.)	13.34	1296
362+03	NB LANES AT CO. RD. 226 (OUTSIDE SHLDR.)	20.07	1815
363+99	SB LANES AT CO. RD. 226 (OUTSIDE SHLDR.)	20.07	1815
363+99	SB LANES AT CO. RD. 226 (INSIDE SHLDR.)	13.34	1296
978+88	NB LANES AT HWY. 463 (OUTSIDE SHLDR.)	20.07	1815
979+21	NB LANES AT HWY. 463 (INSIDE SHLDR.)	13.34	1296
984+10	SB LANES AT HWY. 463 (INSIDE SHLDR.)	13.34	1296
984+43	SB LANES AT HWY. 463 (OUTSIDE SHLDR.)	20.07	1815
1085+74	NB LANES AT LITTLE BAY DITCH (INSIDE SHLDR.)	13.34	1296
1086+07	NB LANES AT LITTLE BAY DITCH (OUTSIDE SHLDR.)	20.07	1815
1086+48	SB LANES AT LITTLE BAY DITCH (OUTSIDE SHLDR.)	20.07	1815
1086+81	SB LANES AT LITTLE BAY DITCH (INSIDE SHLDR.)	13.34	1296
TOTALS:		340.83	31629

QUANTITIES

7/11/2014 11:02:47 AM P:\100038109\CAADD\GEN\63sum04.dgn

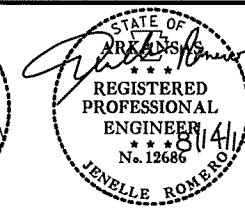

DATE REVISED	DATE FILMED	DATE REVISED	DATE FILMED	FED. RD. DIST. NO.	STATE	FED. AID PROJ. NO.	SHEET NO.	TOTAL SHEETS
				6	ARK.			
				JOB NO.		02196	47	88

SUMMARY OF QUANTITIES AND REVISIONS

SUMMARY OF QUANTITIES

ITEM NUMBER	ITEM	QUANTITY	UNIT
SP	REMOVAL AND DISPOSAL OF IMPACT ATTENUATION BARRIER	20	EACH
210	UNCLASSIFIED EXCAVATION	2645	CU. YD.
210	COMPACTED EMBANKMENT	841	CU. YD.
303	AGGREGATE BASE COURSE (CLASS 7)	8000	TON
SP, SS & 407	MINERAL AGGREGATE IN ACHM SURFACE COURSE (1/2")	1971	TON
SP, SS & 407	ASPHALT BINDER (PG 64-22) IN ACHM SURFACE COURSE (1/2")	108	TON
504	APPROACH GUTTERS	340.83	CU. YD.
601	MOBILIZATION	1.00	LUMP SUM
SP & 603	MAINTENANCE OF TRAFFIC	1.00	LUMP SUM
603	TRAFFIC CONTROL SUPERVISOR	1.00	LUMP SUM
604	SIGNS	1169	SQ. FT.
604	TRAFFIC DRUMS	421	EACH
604	ADVANCE WARNING ARROW PANEL	120	DAY
SP & 604	PORTABLE CHANGEABLE MESSAGE SIGN	86	WEEK
604	FURNISHING AND INSTALLING PRECAST CONCRETE BARRIER	2765	LIN. FT.
604	RELOCATING PRECAST CONCRETE BARRIER	8295	LIN. FT.
SP & 605	CONCRETE DITCH PAVING (TYPE B)	70909	SQ. YD.
617	GUARDRAIL (TYPE A)	14650	LIN. FT.
617	TERMINAL ANCHOR POSTS (TYPE 1)	20	EACH
617	GUARDRAIL TERMINAL (TYPE 2)	40	EACH
617	THREE BEAM GUARDRAIL TERMINAL	20	EACH
620	LIME	104	TON
620	SEEDING	52.05	ACRE
SS & 620	MULCH COVER	104.10	ACRE
620	WATER	7264.1	M. GAL.
621	TEMPORARY SEEDING	52.05	ACRE
621	SAND BAG DITCH CHECKS	5380	BAG
621	DROP INLET SILT FENCE	4470	LIN. FT.
621	SEDIMENT REMOVAL AND DISPOSAL	434	CU. YD.
623	SECOND SEEDING APPLICATION	52.05	ACRE
624	SOLID SODDING	70909	SQ. YD.
635	ROADWAY CONSTRUCTION CONTROL	1.00	LUMP SUM
804	REINFORCING STEEL - ROADWAY (GRADE 60)	31629	LB.
SP	WIRE ROPE SAFETY FENCE	159841	LIN. FT.
SP	WIRE ROPE SAFETY FENCE MAINTENANCE MATERIALS	1.00	LUMP SUM
SP	WIRE ROPE SAFETY FENCE (POST REPAIR)	50	EACH

RESPONSIBLE FOR QUANTITIES
IN EROSION CONTROL AND
ADVANCE WARNING SIGNS
AND DEVICES TABLES

RESPONSIBLE FOR ALL
OTHER QUANTITIES

REVISIONS

DATE	REVISION	SHEET NUMBER

P:\00038109\CA00\GEN\63sum05.dgn 8/14/2014 9:25:10 AM

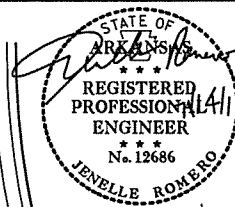

DATE REVISED	DATE FILMED	DATE REVISED	DATE FILMED	FED. RD. DIST. NO.	STATE	FED. AID PROJ. NO.	SHEET NO.	TOTAL SHEETS
				6	ARK.			
				JOB NO.	012196	48	88	

PLAN SHEETS

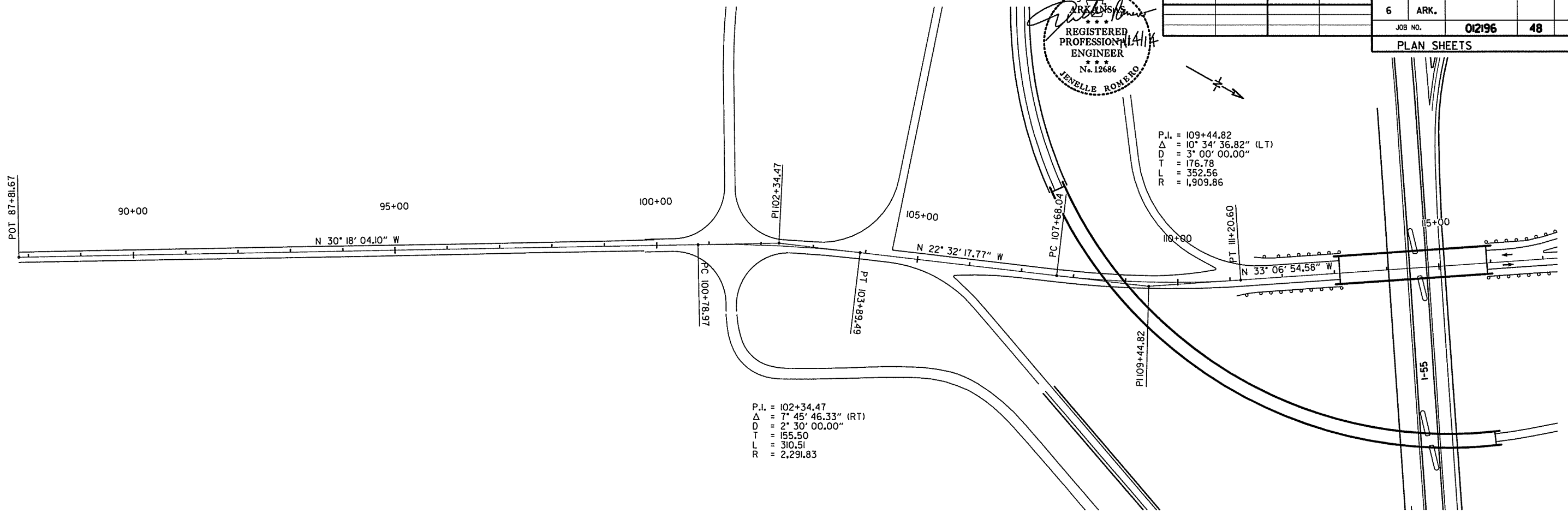

STA. 122+25.00
 BEGIN JOB 012196
 SECTION 10
 BEGIN WRSF
 ON NB FORESLOPE
 LOG MILE 3.46

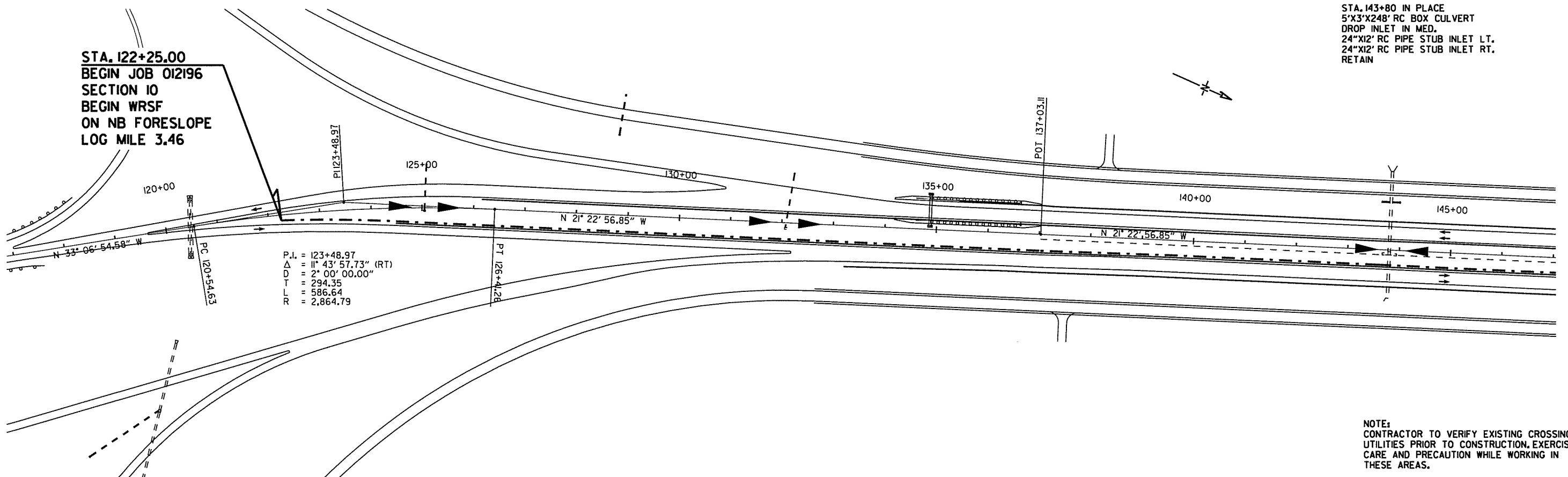

STA. 143+80 IN PLACE
 5'X3'X248' RC BOX CULVERT
 DROP INLET IN MED.
 24"X12' RC PIPE STUB INLET LT.
 24"X12' RC PIPE STUB INLET RT.
 RETAIN

STA. 125+05 IN PLACE
 TYPE R DROP INLET IN MED.
 RETAIN

STA. 132+10 IN PLACE
 TYPE R DROP INLET IN MED.
 RETAIN

NOTE:
 CONTRACTOR TO VERIFY EXISTING CROSSING
 UTILITIES PRIOR TO CONSTRUCTION. EXERCISE
 CARE AND PRECAUTION WHILE WORKING IN
 THESE AREAS.

PLAN SHEETS
 STA. 87+81.67 - STA. 147+00

7/17/2014 11:02:52 AM P:\N00038109\CADD\PAV\HWY63-1.dgn

STA. 49+63 IN PLACE
24"X176' RC PIPE OUTLET
DROP INLET IN MED.
RETAIN

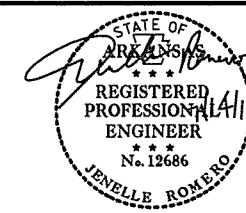

DATE REVISED	DATE FILMED	DATE REVISED	DATE FILMED	FED. RD. DIST. NO.	STATE	FED. AID PROJ. NO.	SHEET NO.	TOTAL SHEETS
				6	ARK.			
				JOB NO.	012196		49	88

PLAN SHEETS

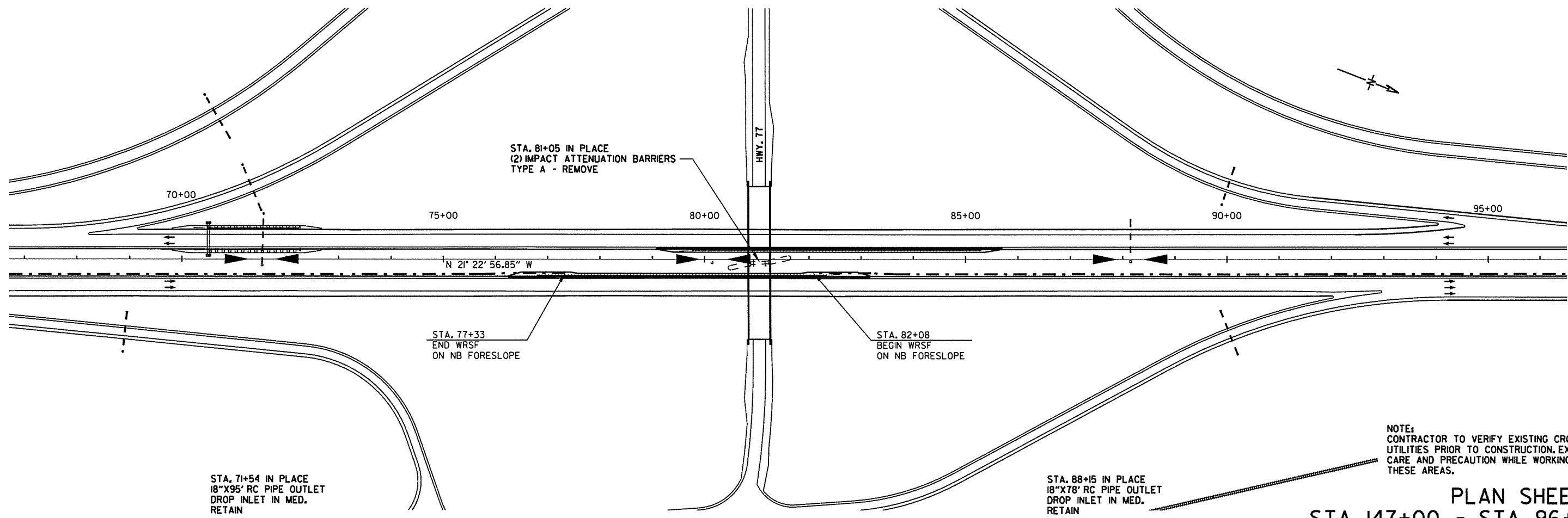
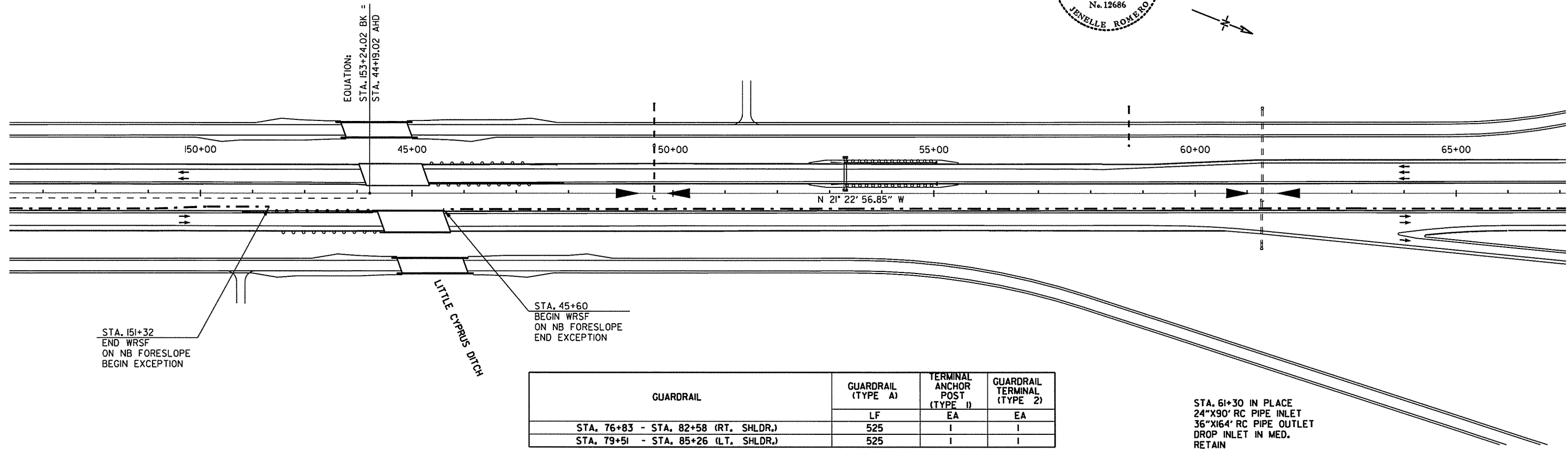

NOTE:
CONTRACTOR TO VERIFY EXISTING CROSSING UTILITIES PRIOR TO CONSTRUCTION. EXERCISE CARE AND PRECAUTION WHILE WORKING IN THESE AREAS.

PLAN SHEETS
STA. 147+00 - STA. 96+00

7/17/2014 10:25:53 AM P:\100038105\CADD\PAV\HWY63-2.dgn

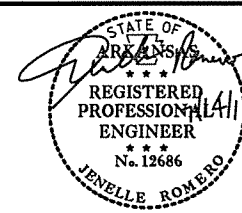

DATE REVISED	DATE FILMED	DATE REVISED	DATE FILMED	FED. RD. DIST. NO.	STATE	FED. AID PROJ. NO.	SHEET NO.	TOTAL SHEETS
				6	ARK.			
				JOB NO.	012196	50	88	

PLAN SHEETS

P.I. = 102+63.67
 Δ = 12° 40' 00.00" (LT)
 D = 1' 40' 34.44"
 T = 379.38
 L = 755.66
 R = 3,418.13

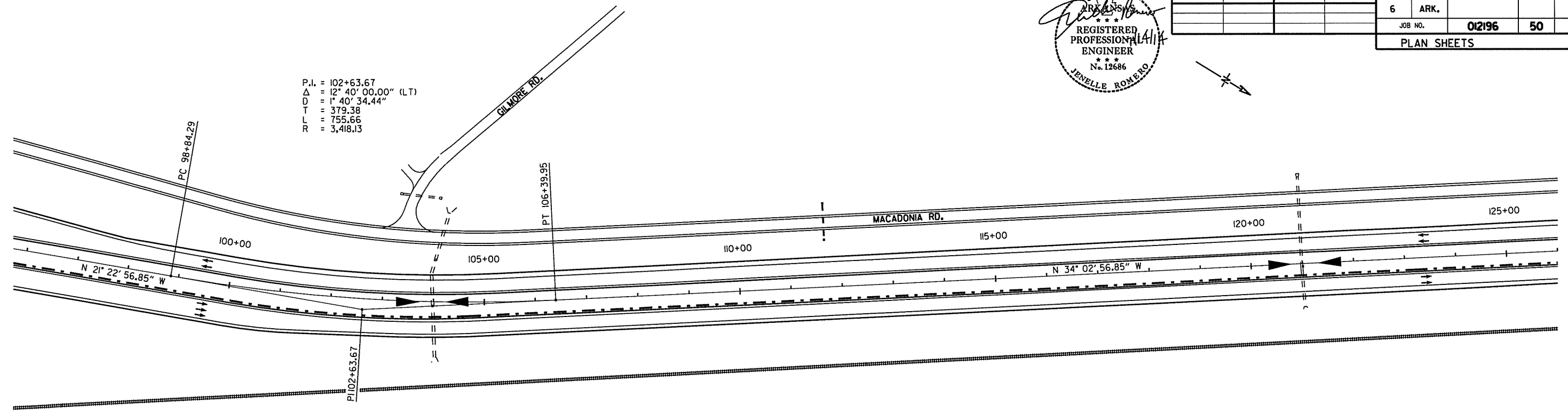

N. BENTON MOORE RD.

STA. 103+99 IN PLACE
 5'X4'X288' RC BOX CULVERT
 DROP INLET IN MED.
 RETAIN

STA. 121+01 IN PLACE
 DROP INLET IN MED.
 RETAIN

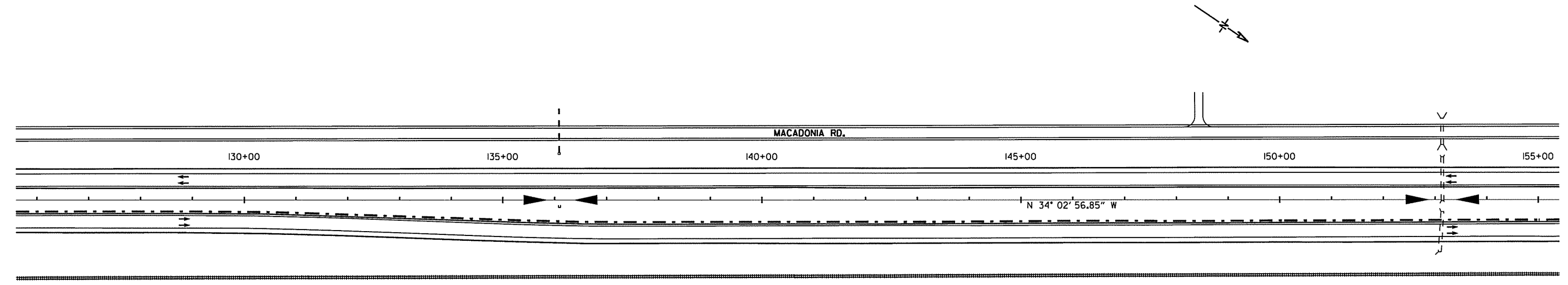

STA. 136+09 IN PLACE
 DROP INLET IN MED.
 RETAIN

NOTE:
 CONTRACTOR TO VERIFY EXISTING CROSSING UTILITIES PRIOR TO CONSTRUCTION. EXERCISE CARE AND PRECAUTION WHILE WORKING IN THESE AREAS.

PLAN SHEETS
 STA. 96+00 - STA. 155+00

7/11/2014 11:02:54 AM P:\00038109\CADD\PAV\HWY63-3.dgn

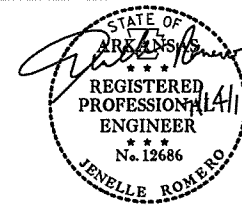

DATE REVISED	DATE FILMED	DATE REVISED	DATE FILMED	FED. RD. DIST. NO.	STATE	FED. AID PROJ. NO.	SHEET NO.	TOTAL SHEETS
				6	ARK.			
						JOB NO.	012196	51
PLAN SHEETS								

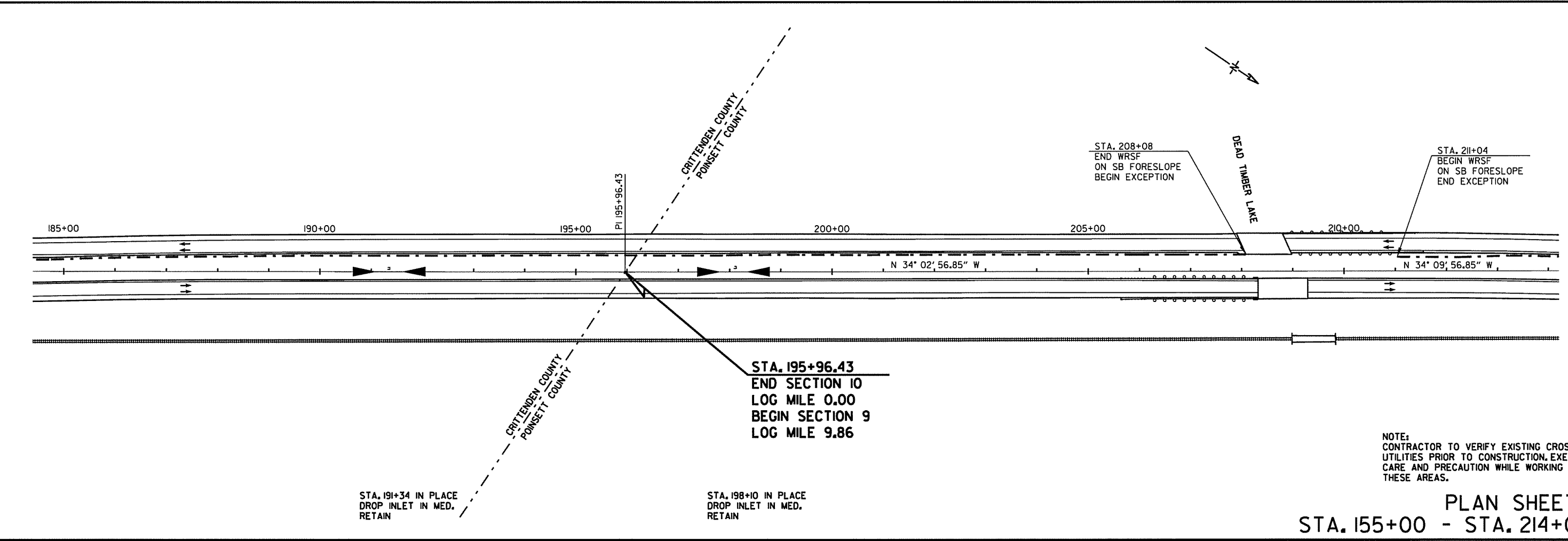
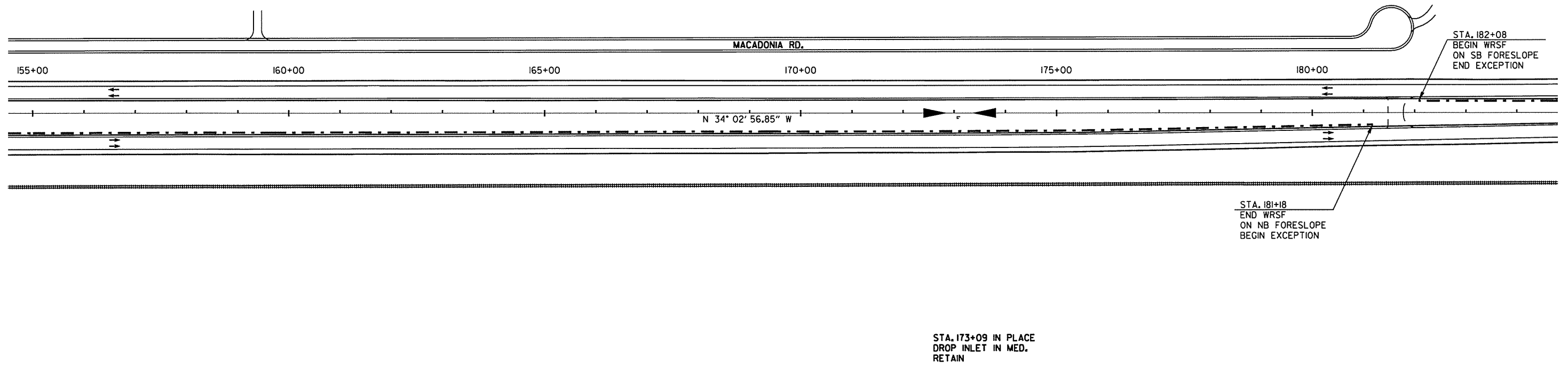

NOTE:
CONTRACTOR TO VERIFY EXISTING CROSSING UTILITIES PRIOR TO CONSTRUCTION. EXERCISE CARE AND PRECAUTION WHILE WORKING IN THESE AREAS.

PLAN SHEETS
STA. 155+00 - STA. 214+00

7/17/2014 11:02:54 AM P:\100038109\CADD\PAV\HWY63-4.dgn

STA. 222+09 IN PLACE
 18"X94' RC PIPE OUTLET
 DROP INLET IN MED.
 RETAIN

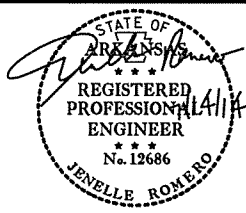

DATE REVISED	DATE FILMED	DATE REVISED	DATE FILMED	FED. RD. DIST. NO.	STATE	FED. AID PROJ. NO.	SHEET NO.	TOTAL SHEETS
				6	ARK.			
				JOB NO.	012196		52	88

PLAN SHEETS

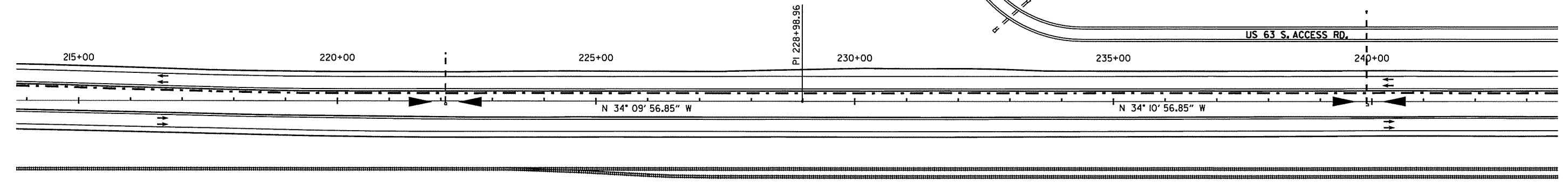

STA. 239+90 IN PLACE
 DROP INLET IN MED.
 RETAIN

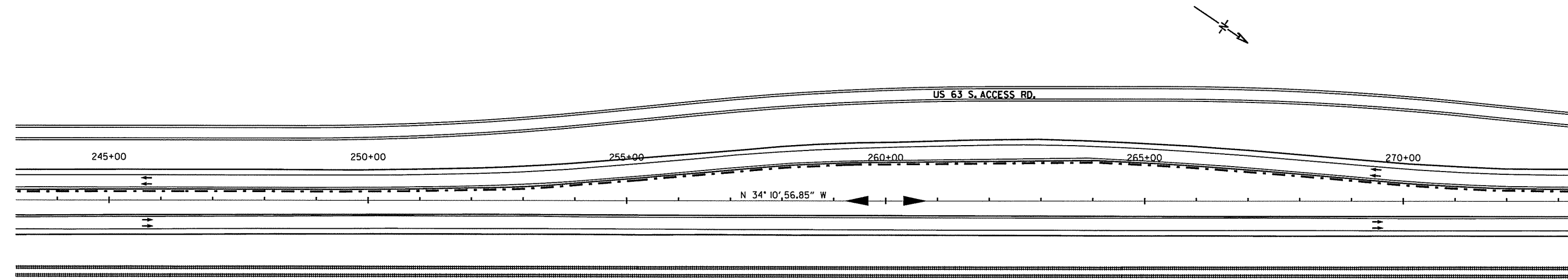

NOTE:
 CONTRACTOR TO VERIFY EXISTING CROSSING UTILITIES PRIOR TO CONSTRUCTION. EXERCISE CARE AND PRECAUTION WHILE WORKING IN THESE AREAS.

PLAN SHEETS
 STA. 214+00 - STA. 273+00

7/11/2014 10:25:55 AM P:\N0003809\CA00\PAV\HWY63-5.dgn

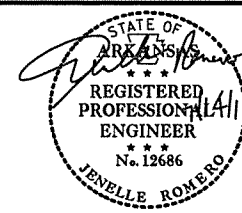

DATE REVISED	DATE FILMED	DATE REVISED	DATE FILMED	FED. RD. DIST. NO.	STATE	FED. AID PROJ. NO.	SHEET NO.	TOTAL SHEETS
				6	ARK.			
				JOB NO.	012196		53	88

PLAN SHEETS

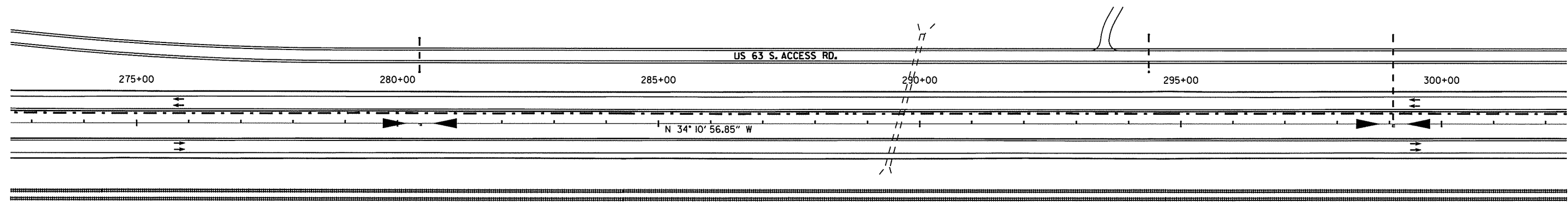

STA. 280+43 IN PLACE
DROP INLET IN MED.
RETAIN

STA. 299+08 IN PLACE
DROP INLET IN MED.
RETAIN

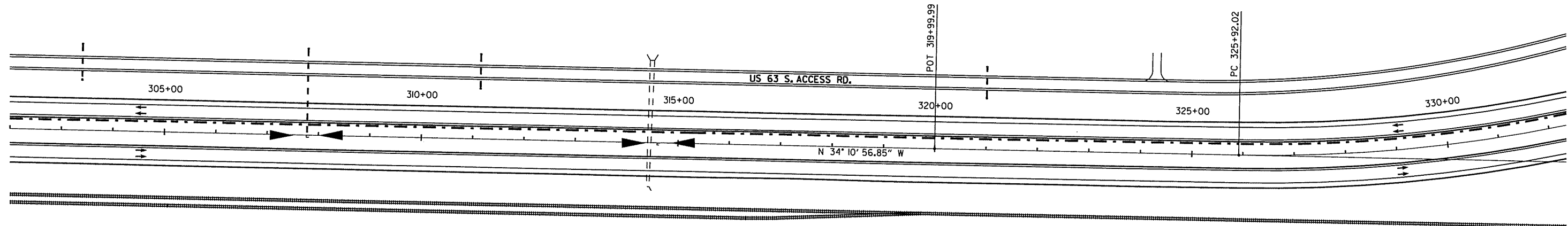

STA. 307+78 IN PLACE
DROP INLET IN MED.
RETAIN

STA. 314+62 IN PLACE
DROP INLET IN MED.
RETAIN

NOTE:
CONTRACTOR TO VERIFY EXISTING CROSSING
UTILITIES PRIOR TO CONSTRUCTION. EXERCISE
CARE AND PRECAUTION WHILE WORKING IN
THESE AREAS.

PLAN SHEETS
STA. 273+00 - STA. 332+00

7/17/2014 11:02:55 AM P:\100038105\CADD\PAV\HWY63-6.dgn

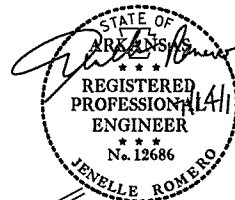

DATE REVISED	DATE FILMED	DATE REVISED	DATE FILMED	FED. RD. DIST. NO.	STATE	FED. AID PROJ. NO.	SHEET NO.	TOTAL SHEETS
				6	ARK.			
				JOB NO.		012196	54	88

PLAN SHEETS

P.I. = 332+54.17
 Δ = 26° 01' 43.11" (LT)
 D = 2° 00' 00.00"
 T = 662.14
 L = 1,301.43
 R = 2,864.79

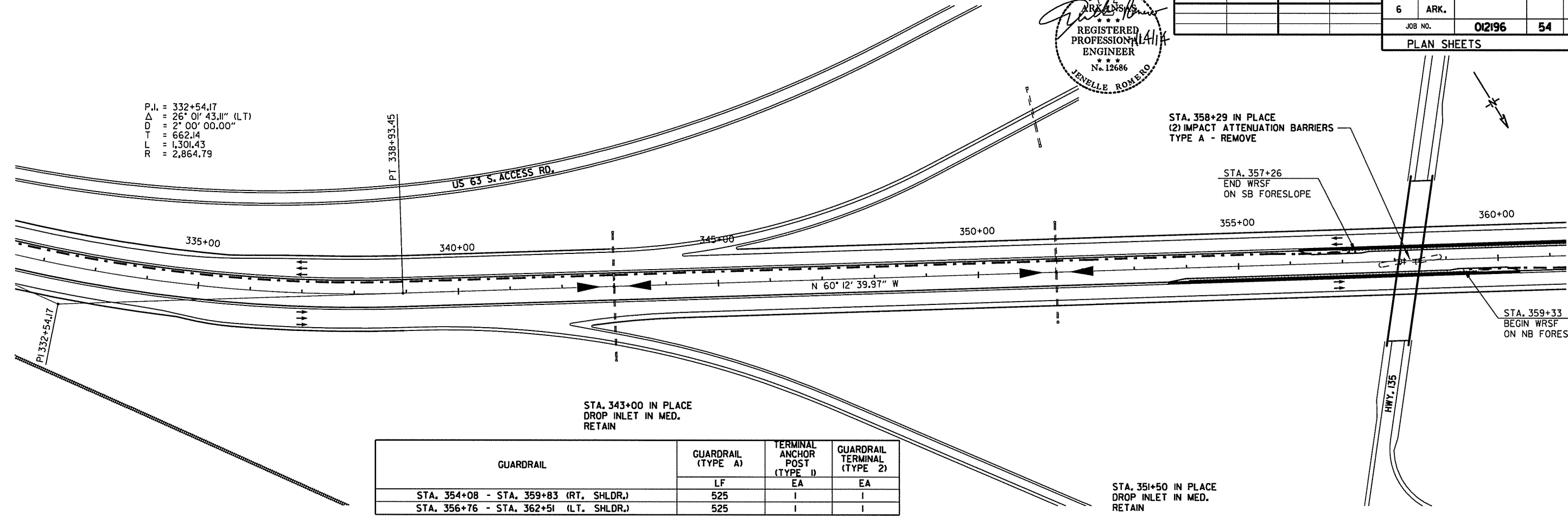

STA. 365+00 IN PLACE
DROP INLET IN MED.
RETAIN

STA. 377+75 IN PLACE
DROP INLET IN MED.
RETAIN

STA. 391+00 IN PLACE
DROP INLET IN MED.
RETAIN

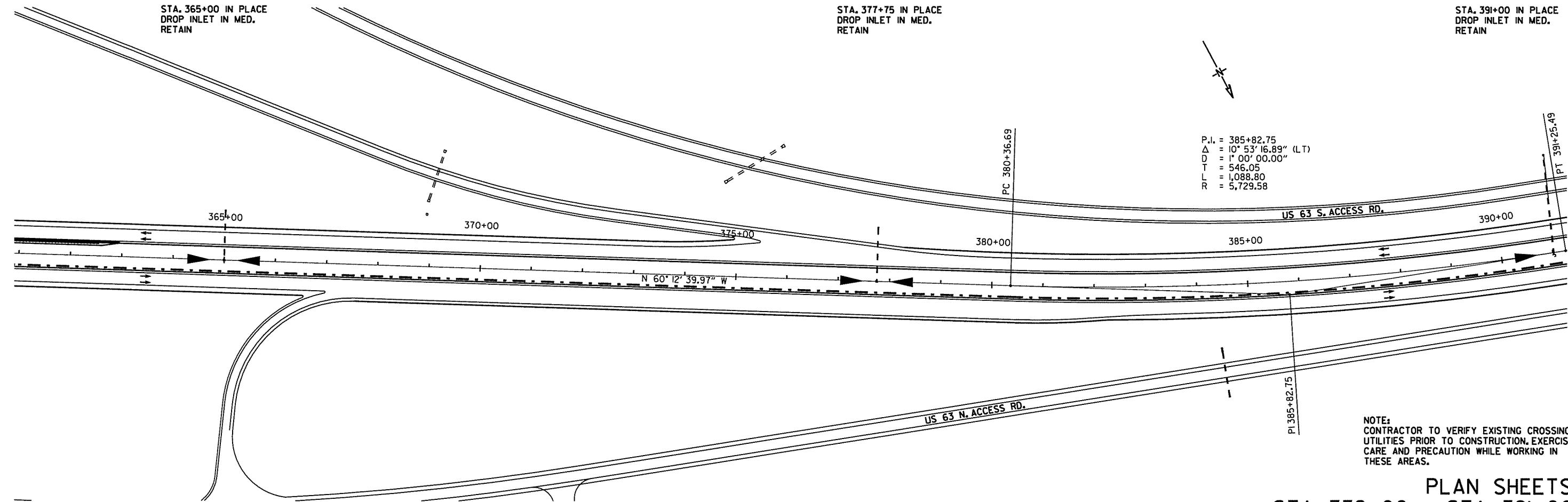

NOTE:
 CONTRACTOR TO VERIFY EXISTING CROSSING UTILITIES PRIOR TO CONSTRUCTION. EXERCISE CARE AND PRECAUTION WHILE WORKING IN THESE AREAS.

PLAN SHEETS
 STA. 332+00 - STA. 391+00

7/17/2014 11:02:57 AM P:\100038105\CADD\PAV\HWY63-7.dgn

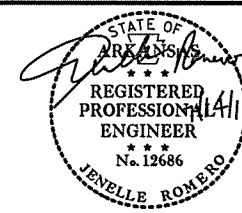

DATE REVISED	DATE FILMED	DATE REVISED	DATE FILMED	FED. RD. DIST. NO.	STATE	FED. AID PROJ. NO.	SHEET NO.	TOTAL SHEETS
				6	ARK.			
JOB NO. 012196							55	88

PLAN SHEETS

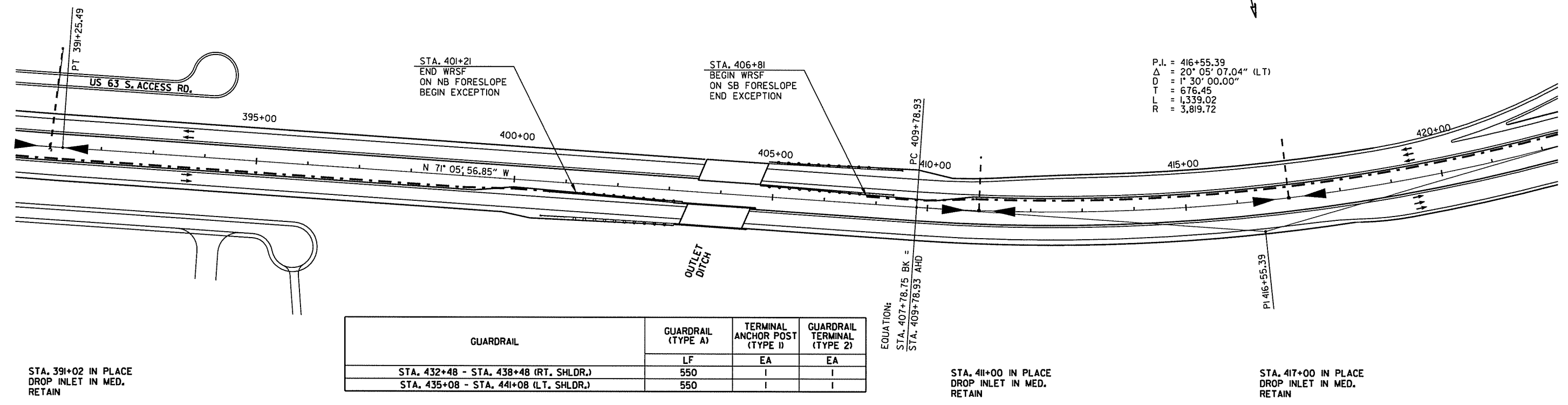

GUARDRAIL	GUARDRAIL (TYPE A)	TERMINAL ANCHOR POST (TYPE 1)	GUARDRAIL TERMINAL (TYPE 2)
	LF	EA	EA
STA. 432+48 - STA. 438+48 (RT. SHLDR.)	550		
STA. 435+08 - STA. 441+08 (LT. SHLDR.)	550		

STA. 391+02 IN PLACE
DROP INLET IN MED.
RETAIN

STA. 411+00 IN PLACE
DROP INLET IN MED.
RETAIN

STA. 417+00 IN PLACE
DROP INLET IN MED.
RETAIN

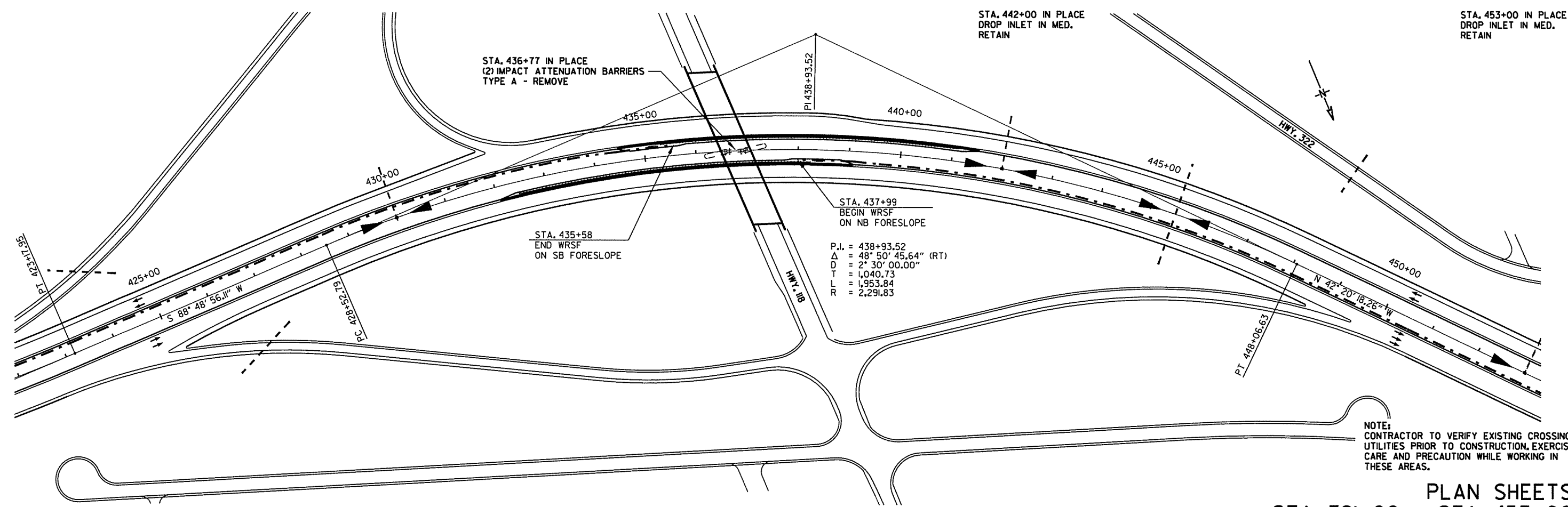

STA. 436+77 IN PLACE
(2) IMPACT ATTENUATION BARRIERS
TYPE A - REMOVE

STA. 437+99
BEGIN WRSF
ON NB FORESLOPE

STA. 435+58
END WRSF
ON SB FORESLOPE

STA. 442+00 IN PLACE
DROP INLET IN MED.
RETAIN

STA. 453+00 IN PLACE
DROP INLET IN MED.
RETAIN

NOTE:
CONTRACTOR TO VERIFY EXISTING CROSSING UTILITIES PRIOR TO CONSTRUCTION. EXERCISE CARE AND PRECAUTION WHILE WORKING IN THESE AREAS.

PLAN SHEETS
STA. 391+00 - STA. 453+00

7/11/2014 11:02:58 AM P:\100038105\CADD\PAV\HWY63-8.dgn

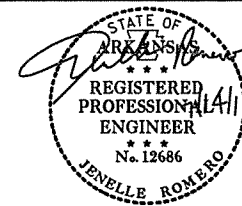

DATE REVISED	DATE FILMED	DATE REVISED	DATE FILMED	FED. RD. DIST. NO.	STATE	FED. AID PROJ. NO.	SHEET NO.	TOTAL SHEETS
				6	ARK.			
JOB NO. 012196							56	88

PLAN SHEETS

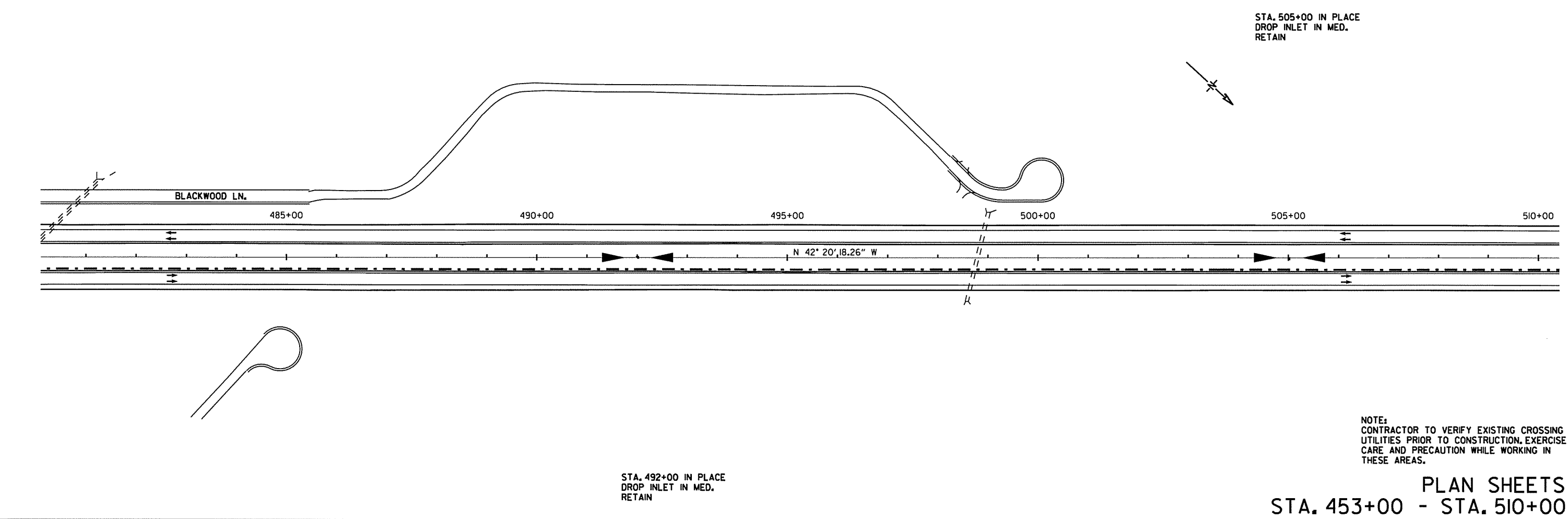
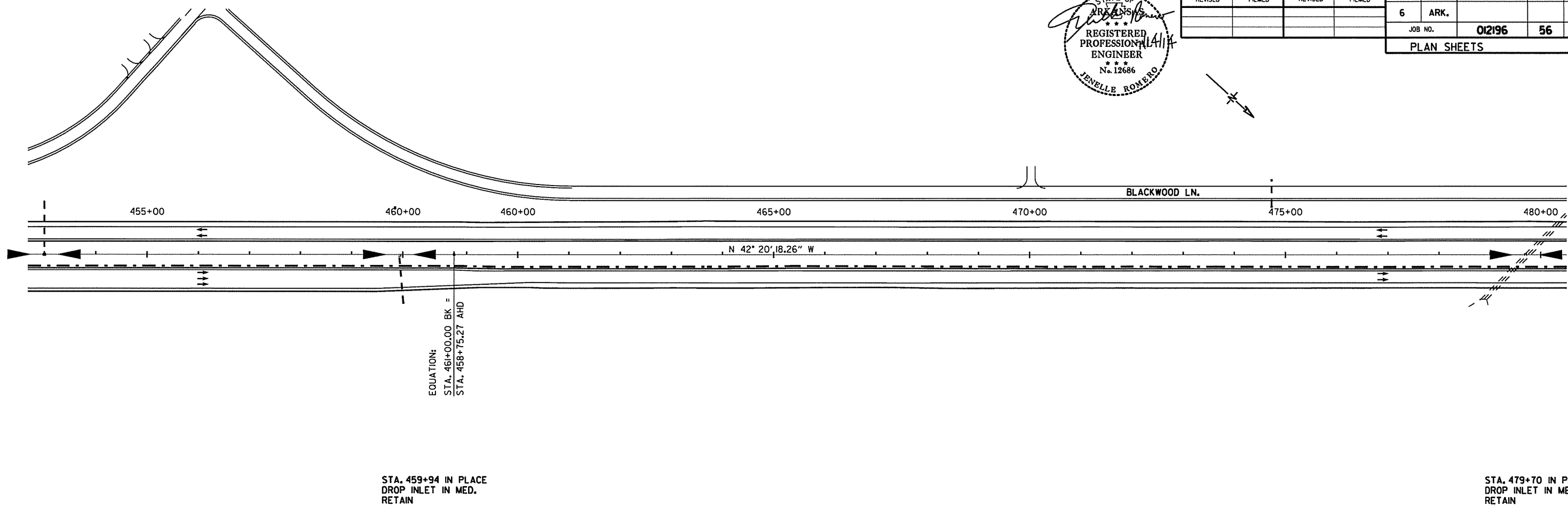

NOTE:
CONTRACTOR TO VERIFY EXISTING CROSSING UTILITIES PRIOR TO CONSTRUCTION, EXERCISE CARE AND PRECAUTION WHILE WORKING IN THESE AREAS.

PLAN SHEETS
STA. 453+00 - STA. 510+00

7/17/2014 11:02:59 AM P:\00038109\CA00\PAV\HWY63-9.dgn

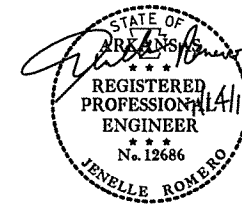

DATE REVISED	DATE FILMED	DATE REVISED	DATE FILMED	FED. RD. DIST. NO.	STATE	FED. AID PROJ. NO.	SHEET NO.	TOTAL SHEETS
				6	ARK.		57	88
				JOB NO.		02196		

PLAN SHEETS

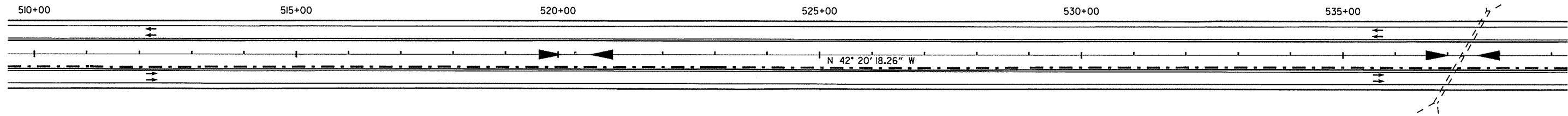

STA. 520+34 IN PLACE
DROP INLET IN MED.
RETAIN

STA. 537+58 IN PLACE
6'X6'X200' RC BOX CULVERT
45° LT. FWD. SKEW
DROP INLET IN MED.
RETAIN

P.I. = 559+81.60
Δ = 4° 00' 00.00" (LT)
D = 1° 00' 00.00"
T = 200.08
L = 400.00
R = 5,729.58

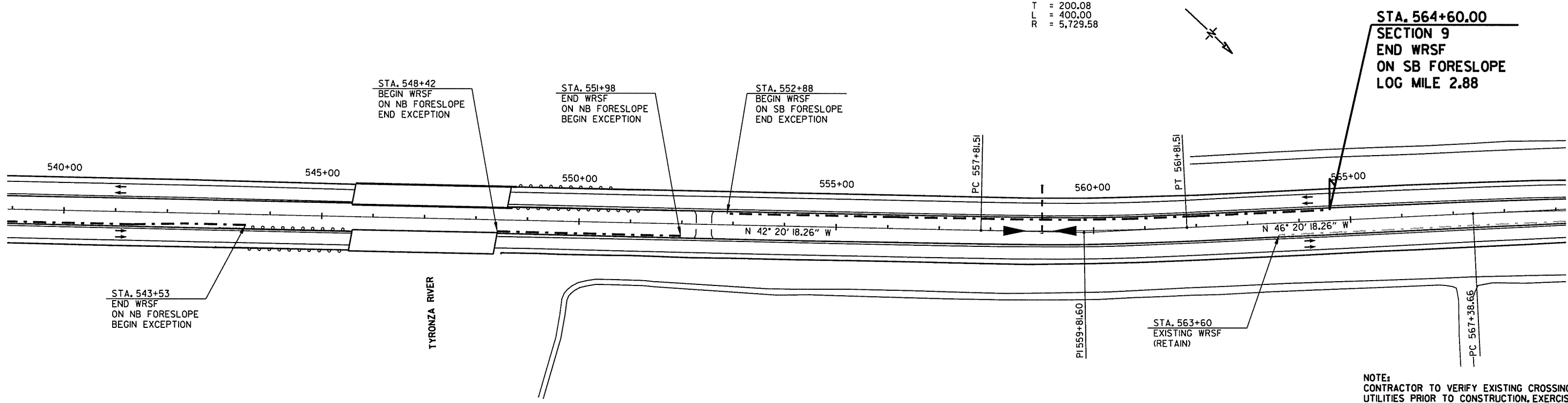

STA. 564+60.00
SECTION 9
END WRSF
ON SB FORESLOPE
LOG MILE 2.88

NOTE:
CONTRACTOR TO VERIFY EXISTING CROSSING
UTILITIES PRIOR TO CONSTRUCTION. EXERCISE
CARE AND PRECAUTION WHILE WORKING IN
THESE AREAS.

STA. 559+00 IN PLACE
24"X86' RC PIPE OUTLET
DROP INLET IN MED.
RETAIN

PLAN SHEETS
STA. 510+00 - STA. 569+00

7/17/2014 11:02:59 AM P:\100038103\CADD\PAV\HWY63-10.dgn

DATE REVISED	DATE FILMED	DATE REVISED	DATE FILMED	FED. RD. DIST. NO.	STATE	FED. AID PROJ. NO.	SHEET NO.	TOTAL SHEETS
				6	ARK.			
						JOB NO.	02196	58
PLAN SHEETS								

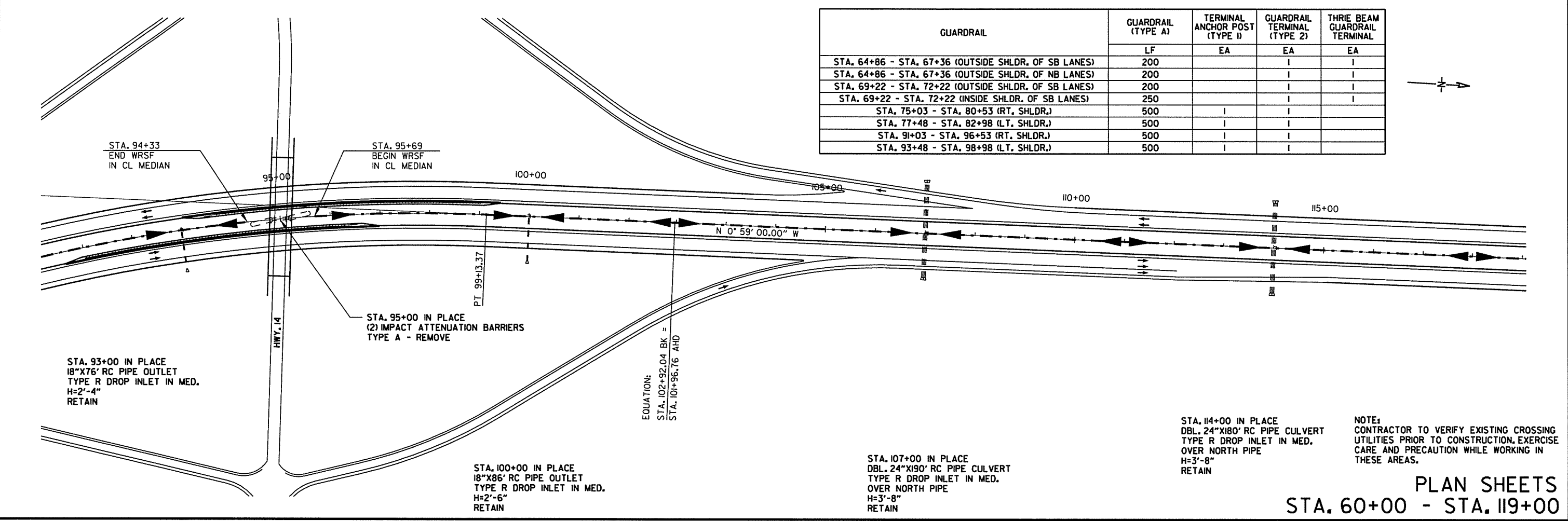
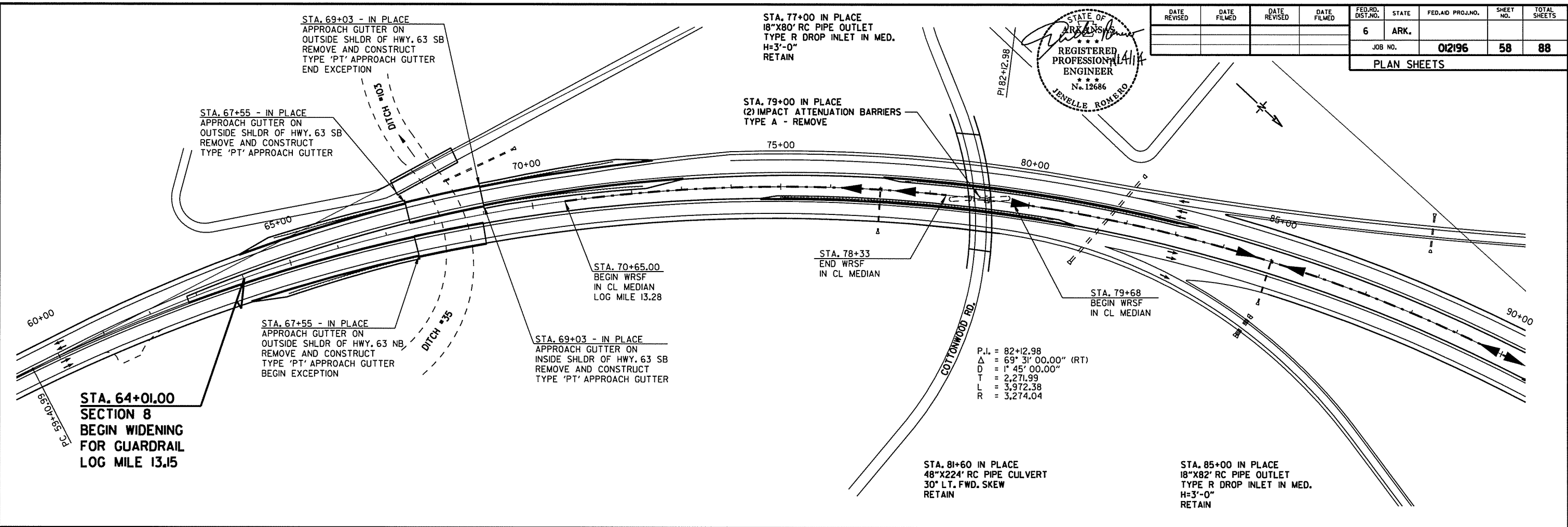
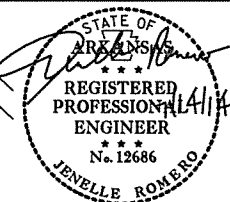

GUARDRAIL	GUARDRAIL (TYPE A)	TERMINAL ANCHOR POST (TYPE 1)	GUARDRAIL TERMINAL (TYPE 2)	THRIE BEAM GUARDRAIL TERMINAL
	LF	EA	EA	EA
STA. 64+86 - STA. 67+36 (OUTSIDE SHLDR. OF SB LANES)	200			
STA. 64+86 - STA. 67+36 (OUTSIDE SHLDR. OF NB LANES)	200			
STA. 69+22 - STA. 72+22 (OUTSIDE SHLDR. OF SB LANES)	200			
STA. 69+22 - STA. 72+22 (INSIDE SHLDR. OF SB LANES)	250			
STA. 75+03 - STA. 80+53 (RT. SHLDR.)	500			
STA. 77+48 - STA. 82+98 (LT. SHLDR.)	500			
STA. 91+03 - STA. 96+53 (RT. SHLDR.)	500			
STA. 93+48 - STA. 98+98 (LT. SHLDR.)	500			

NOTE:
CONTRACTOR TO VERIFY EXISTING CROSSING UTILITIES PRIOR TO CONSTRUCTION. EXERCISE CARE AND PRECAUTION WHILE WORKING IN THESE AREAS.

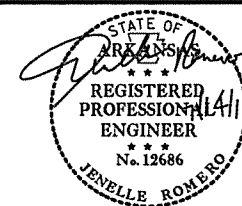

DATE REVISED	DATE FILMED	DATE REVISED	DATE FILMED	FED. RD. DIST. NO.	STATE	FED. AID PROJ. NO.	SHEET NO.	TOTAL SHEETS
				6	ARK.			
						JOB NO.	012196	59 88

PLAN SHEETS

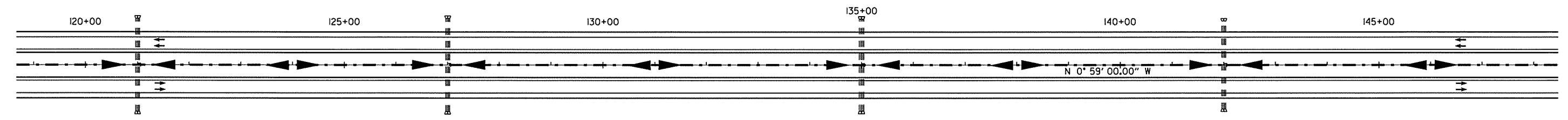
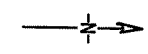

STA. 121+00 IN PLACE
DBL. 24\"X180\" RC PIPE CULVERT
TYPE R DROP INLET IN MED.
OVER NORTH PIPE
H=3'-8"
RETAIN

STA. 127+00 IN PLACE
DBL. 24\"X180\" RC PIPE CULVERT
TYPE R DROP INLET IN MED.
OVER NORTH PIPE
H=3'-8"
RETAIN

STA. 135+00 IN PLACE
DBL. 30\"X178\" RC PIPE CULVERT
TYPE R DROP INLET IN MED.
OVER NORTH PIPE
H=3'-10"
RETAIN

STA. 142+00 IN PLACE
DBL. 24\"X170\" RC PIPE CULVERT
TYPE R DROP INLET IN MED.
OVER NORTH PIPE
H=2'-10"
RETAIN

STA. 149+00 IN PLACE
18\"X88\" RC PIPE OUTLET
TYPE R DROP INLET IN MED.
H=2'-6"
RETAIN

STA. 159+81 - IN PLACE
APPROACH GUTTER ON
INSIDE SHLDR OF HWY. 63 NB
REMOVE AND CONSTRUCT
TYPE 'PT' APPROACH GUTTER

STA. 158+09
END WRSF
IN CL MEDIAN

STA. 161+18 - IN PLACE
APPROACH GUTTER ON
OUTSIDE SHLDR OF HWY. 63 SB
REMOVE AND CONSTRUCT
TYPE 'PT' APPROACH GUTTER
END EXCEPTION

STA. 159+81 - IN PLACE
APPROACH GUTTER ON
OUTSIDE SHLDR OF HWY. 63 NB
REMOVE AND CONSTRUCT
TYPE 'PT' APPROACH GUTTER
BEGIN EXCEPTION

STA. 162+90
BEGIN WRSF
IN CL MEDIAN

STA. 161+18 - IN PLACE
APPROACH GUTTER ON
INSIDE SHLDR OF HWY. 63 SB
REMOVE AND CONSTRUCT
TYPE 'PT' APPROACH GUTTER

STA. 152+00 IN PLACE
TRIPLE 30\"X260\" RC PIPE CULVERT
40° RT. FWD. SKEW
TYPE R DROP INLET IN MED.
OVER NORTH PIPE
H=6'-9"
RETAIN

STA. 164+00 IN PLACE
DBL. 24\"X238\" RC PIPE CULVERT
RETAIN

STA. 170+00 IN PLACE
18\"X88\" RC PIPE OUTLET
TYPE R DROP INLET IN MED.
H=2'-7"
RETAIN

STA. 173+90 IN PLACE
DBL. 24\"X176\" RC PIPE CULVERT
TYPE R DROP INLET IN MED.
OVER NORTH PIPE
H=3'-3"
RETAIN

NOTE:
CONTRACTOR TO VERIFY EXISTING CROSSING
UTILITIES PRIOR TO CONSTRUCTION. EXERCISE
CARE AND PRECAUTION WHILE WORKING IN
THESE AREAS.

GUARDRAIL	GUARDRAIL (TYPE A)	TERMINAL ANCHOR POST (TYPE 1)	GUARDRAIL TERMINAL (TYPE 2)	THREE BEAM GUARDRAIL TERMINAL
	LF	EA	EA	EA
STA. 155+99 - STA. 158+99 (INSIDE SHLDR. OF NB LANES)	250		I	I
STA. 156+49 - STA. 158+99 (OUTSIDE SHLDR. OF NB LANES)	200		I	I
STA. 161+37 - STA. 163+87 (OUTSIDE SHLDR. OF SB LANES)	200		I	I
STA. 161+37 - STA. 164+37 (INSIDE SHLDR. OF SB LANES)	250		I	I

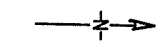
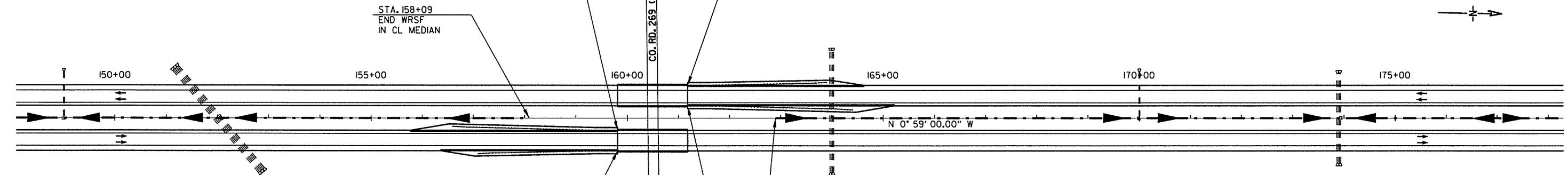

PLAN SHEETS
STA. 119+00 - STA. 178+00

7/11/2014 11:03:02 AM

P:\100038109\CADD\PAV\HWY63\12.dgn

STA. 194+00 IN PLACE
 18"X90' RC PIPE OUTLET
 TYPE R DROP INLET IN MED.
 H=3'-5"
 RETAIN

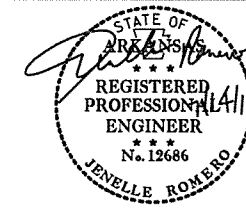

DATE REVISED	DATE FILMED	DATE REVISED	DATE FILMED	FED. RD. DIST. NO.	STATE	FED. AID PROJ. NO.	SHEET NO.	TOTAL SHEETS
				6	ARK.			
						JOB NO.	012196	60
						PLAN SHEETS		
							88	

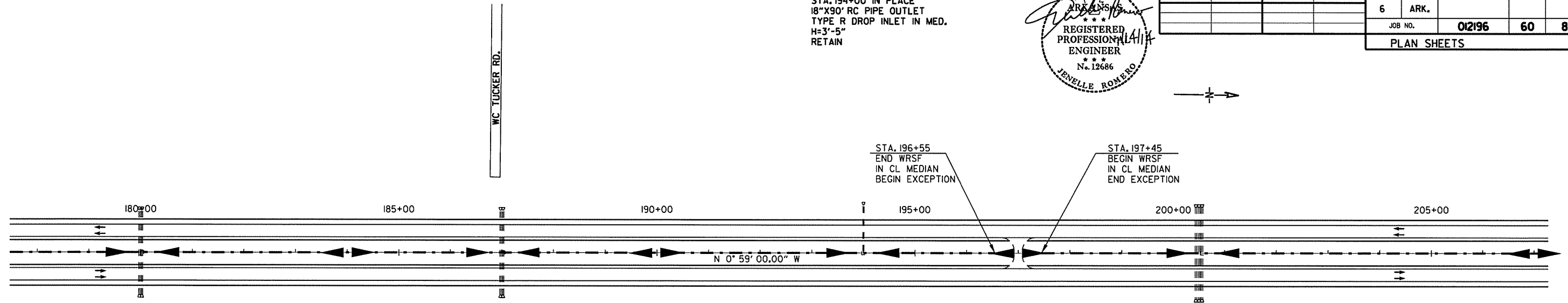

STA. 180+00 IN PLACE
 DBL. 24"X164' RC PIPE CULVERT
 TYPE R DROP INLET IN MED.
 OVER NORTH PIPE
 H=2'-9"
 RETAIN

STA. 187+00 IN PLACE
 DBL. 24"X164' RC PIPE CULVERT
 TYPE R DROP INLET IN MED.
 OVER NORTH PIPE
 H=2'-9"
 RETAIN

STA. 200+50 IN PLACE
 TRIPLE 30"X178' RC PIPE CULVERT
 TYPE R DROP INLET IN MED.
 OVER NORTH PIPE
 H=4'-2"
 RETAIN

STA. 220+00 IN PLACE
 18"X84' RC PIPE OUTLET
 TYPE R DROP INLET IN MED.
 H=2'-6"
 RETAIN

STA. 235+00 IN PLACE
 18"X82' RC PIPE OUTLET
 TYPE R DROP INLET IN MED.
 H=2'-2"
 RETAIN

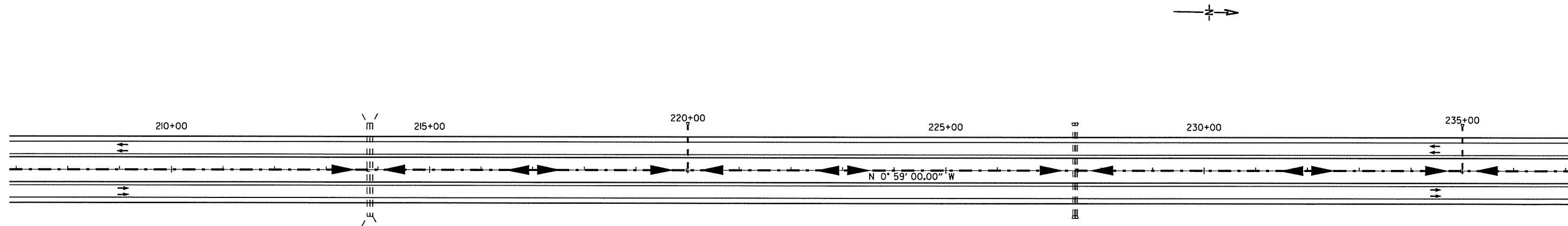

STA. 213+84 IN PLACE
 DBL. 5'X3'X180' RC BOX CULVERT
 TYPE T DROP INLET IN MED.
 OVER SOUTH PIPE
 H=1'-8"
 RETAIN

STA. 227+50 IN PLACE
 DBL. 30"X174' RC PIPE CULVERT
 TYPE R DROP INLET IN MED.
 OVER NORTH PIPE
 H=3'-6"
 RETAIN

NOTE:
 CONTRACTOR TO VERIFY EXISTING CROSSING UTILITIES PRIOR TO CONSTRUCTION, EXERCISE CARE AND PRECAUTION WHILE WORKING IN THESE AREAS.

PLAN SHEETS
 STA. 178+00 - STA. 237+00

7/17/2014 10:03:03 AM

P:\10003809\CAD\VPAY\HWY63-13.dwg

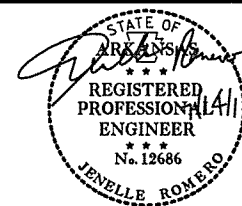

DATE REVISED	DATE FILMED	DATE REVISED	DATE FILMED	FED. RD. DIST. NO.	STATE	FED. AID PROJ. NO.	SHEET NO.	TOTAL SHEETS
				6	ARK.			
							JOB NO.	
							012196	61
							88	

PLAN SHEETS

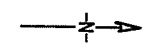

STA. 256+50 IN PLACE
 18"X86' RC PIPE OUTLET
 TYPE R DROP INLET IN MED.
 H=2'-9"
 RETAIN

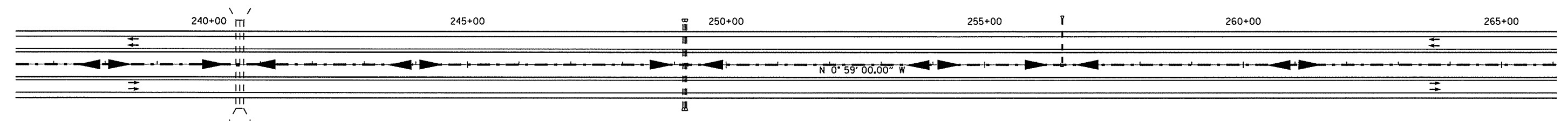

STA. 240+60 IN PLACE
 DBL. 7'X5'X170' RC BOX CULVERT
 TYPE T DROP INLET IN MED.
 OVER SOUTH PIPE
 H=1'-6"
 RETAIN

STA. 249+20 IN PLACE
 DBL. 24"X166' RC PIPE CULVERT
 TYPE R DROP INLET IN MED.
 OVER NORTH PIPE
 H=2'-8"
 RETAIN

STA. 266+84 IN PLACE
 18"X90' RC PIPE OUTLET
 TYPE R DROP INLET IN MED.
 H=3'-0"
 RETAIN

STA. 275+00 IN PLACE
 18"X94' RC PIPE OUTLET
 TYPE R DROP INLET IN MED.
 H=3'-0"
 RETAIN

STA. 283+00 IN PLACE
 18"X94' RC PIPE OUTLET
 TYPE R DROP INLET IN MED.
 H=3'-6"
 RETAIN

STA. 293+90 IN PLACE
 8'X6'X186' RC BOX CULVERT
 TYPE T DROP INLET IN MED.
 H=1'-10"
 RETAIN

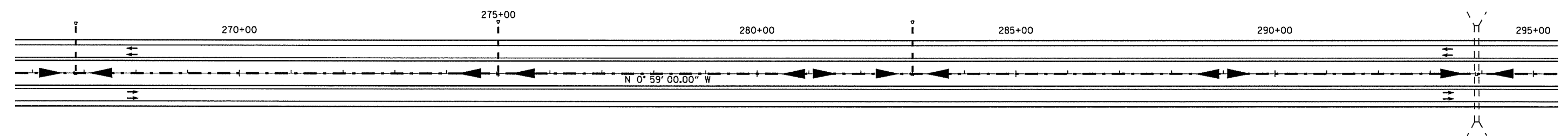
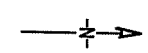

NOTE:
 CONTRACTOR TO VERIFY EXISTING CROSSING UTILITIES PRIOR TO CONSTRUCTION, EXERCISE CARE AND PRECAUTION WHILE WORKING IN THESE AREAS.

PLAN SHEETS
 STA. 237+00 - STA. 295+00

7/17/2014 11:03:03 AM

P:\000038109\CADD\PAV\HWY63-H.dgn

STA. 303+00 IN PLACE
 18"X90' RC PIPE OUTLET
 TYPE R DROP INLET IN MED.
 H=2'-10"
 RETAIN

STA. 311+00 IN PLACE
 18"X88' RC PIPE OUTLET
 TYPE R DROP INLET IN MED.
 H=2'-8"
 RETAIN

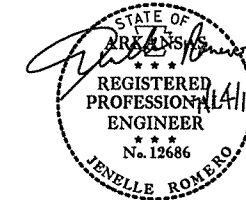

DATE REVISED	DATE FILMED	DATE REVISED	DATE FILMED	FED. RD. DIST. NO.	STATE	FED. AID PROJ. NO.	SHEET NO.	TOTAL SHEETS	
				6	ARK.				
JOB NO.							012196	62	88

PLAN SHEETS

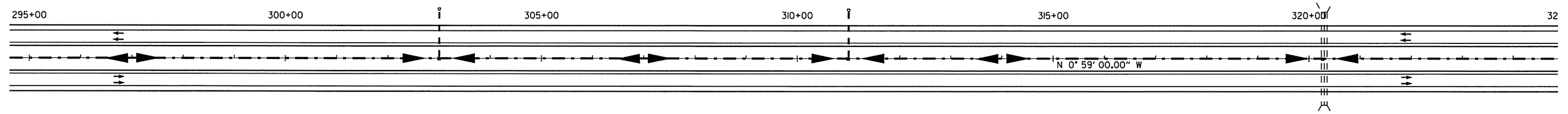

STA. 320+34 IN PLACE
 DBL. 5'X4'X181' RC BOX CULVERT
 TYPE T DROP INLET IN MED.
 OVER SOUTH PIPE
 H=1'-10"
 RETAIN

STA. 329+00 IN PLACE
 18"X92' RC PIPE OUTLET
 TYPE R DROP INLET IN MED.
 H=4'-11"
 RETAIN

STA. 344+00 IN PLACE
 18"X86' RC PIPE OUTLET
 TYPE R DROP INLET IN MED.
 H=3'-1"
 RETAIN

STA. 351+00 IN PLACE
 18"X82' RC PIPE OUTLET
 TYPE R DROP INLET IN MED.
 H=2'-9"
 RETAIN

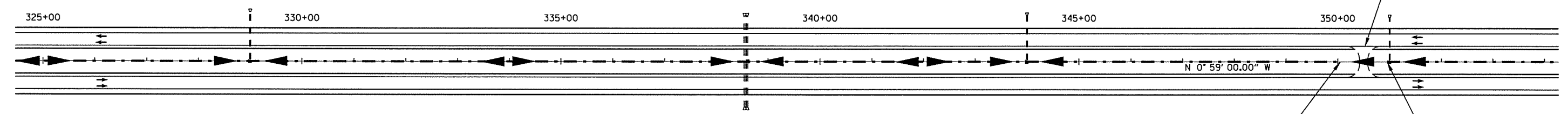

STA. 350+05
 END WRSF
 IN CL MEDIAN
 BEGIN EXCEPTION

STA. 350+95
 BEGIN WRSF
 IN CL MEDIAN
 END EXCEPTION

STA. 338+57 IN PLACE
 DBL. 24"X176' RC PIPE CULVERT
 TYPE R DROP INLET IN MED.
 OVER NORTH PIPE
 H=3'-8"
 RETAIN

NOTE:
 CONTRACTOR TO VERIFY EXISTING CROSSING UTILITIES PRIOR TO CONSTRUCTION, EXERCISE CARE AND PRECAUTION WHILE WORKING IN THESE AREAS.

PLAN SHEETS
 STA. 295+00 - STA. 354+00

7/17/2014 11:03:03 AM P:\00038109\CADD\PAV\HWY63-15.dgn

STA. 356+00 IN PLACE
18"X120" RC PIPE OUTLET
TYPE R DROP INLET IN MED.
H=11'-2"
RETAIN

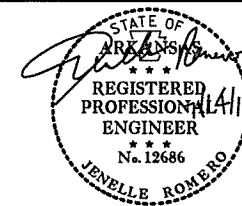

DATE REVISED	DATE FILMED	DATE REVISED	DATE FILMED	FED. RD. DIST. NO.	STATE	FED. AID PROJ. NO.	SHEET NO.	TOTAL SHEETS
				6	ARK.			
						JOB NO.	02196	63 88
PLAN SHEETS								

P.I. = 383+26.74
Δ = 36° 21' 41.00" (LT)
D = 2° 00' 00.00"
T = 940.83
L = 1,818.07
R = 2,864.79

STA. 375+00 IN PLACE
18"X88" RC PIPE OUTLET
TYPE R DROP INLET IN MED.
H=3'-0"
RETAIN

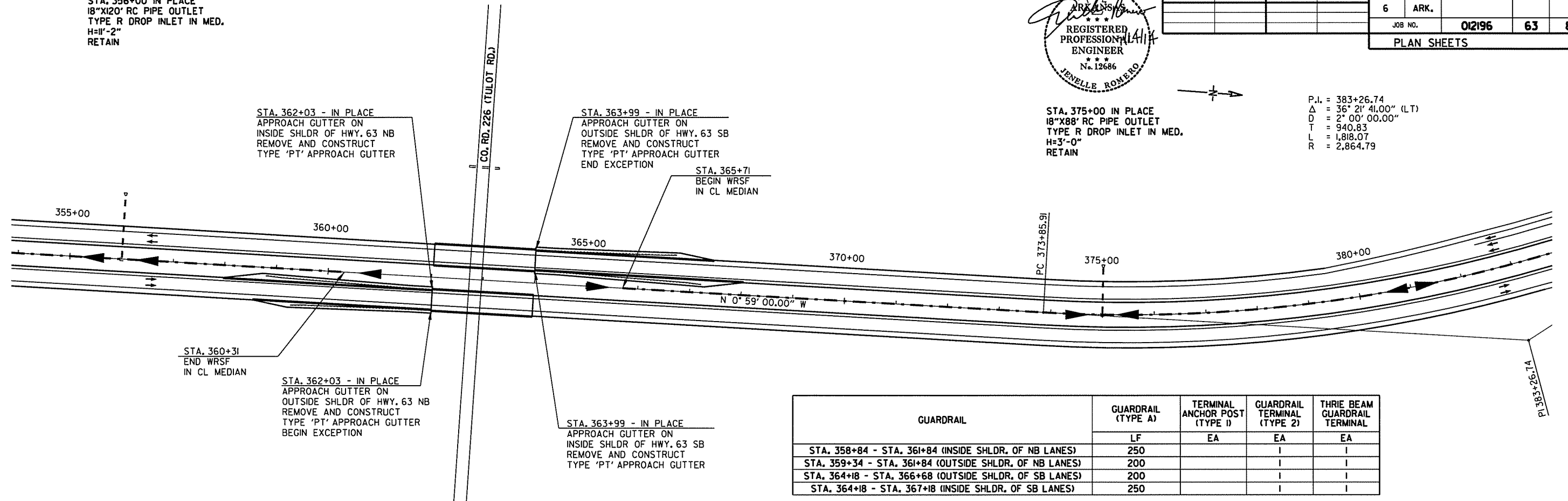

STA. 391+00 IN PLACE
18"X124" RC PIPE OUTLET
TYPE R DROP INLET IN MED.
H=2'-9"
RETAIN

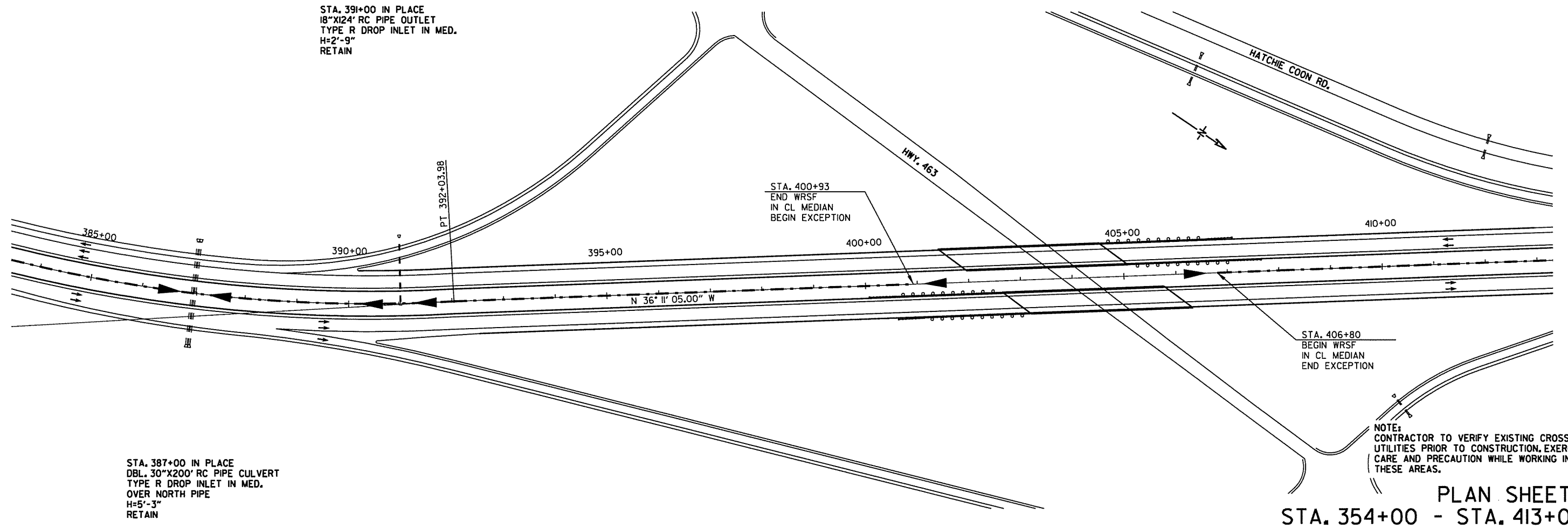

PLAN SHEETS
STA. 354+00 - STA. 413+00

7/11/2014 11:03:05 AM P:\100038109\CAADD\PAV\HWY63-16.dgn

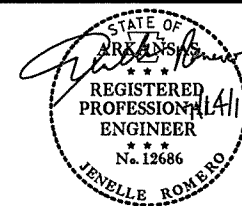

DATE REVISED	DATE FILMED	DATE REVISED	DATE FILMED	FED. RD. DIST. NO.	STATE	FED. AID PROJ. NO.	SHEET NO.	TOTAL SHEETS
				6	ARK.			
JOB NO. 012196							64	88

PLAN SHEETS

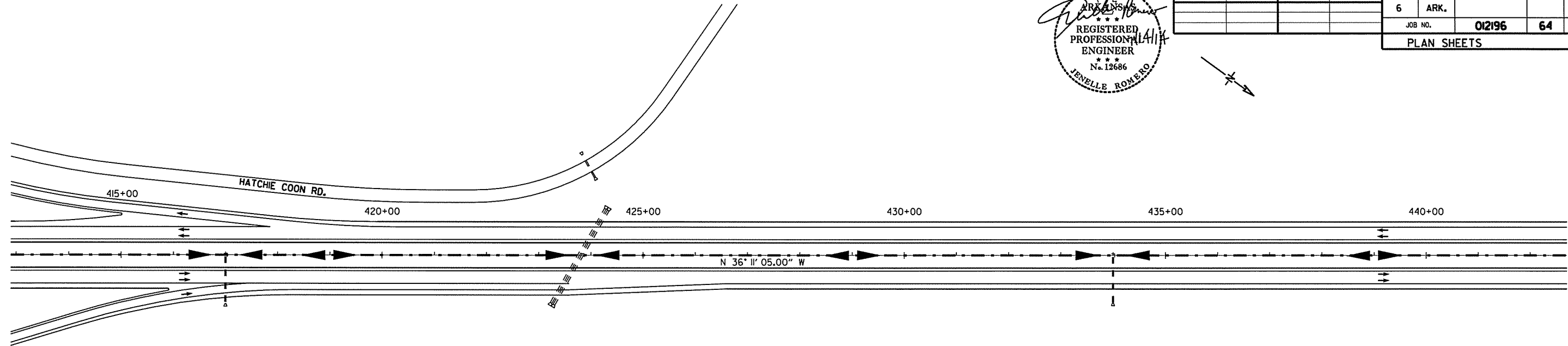

STA. 417+00 IN PLACE
18"X90' RC PIPE OUTLET
TYPE R DROP INLET IN MED.
H=2'-9"
RETAIN

STA. 423+80 IN PLACE
DBL. 36"X208' RC PIPE CULVERT
30° LT. FWD. SKEW
TYPE RM DROP INLET IN MED.
H=3'-10"
RETAIN

STA. 434+00 IN PLACE
18"X88' RC PIPE OUTLET
TYPE RM DROP INLET IN MED.
H=2'-11"
RETAIN

STA. 461+50 IN PLACE
18"X82' RC PIPE OUTLET
TYPE RM DROP INLET IN MED.
H=2'-4"
RETAIN

P.I. = 466+56.51
Δ = 25° 27' 19.00" (LT)
D = 1° 00' 00.00"
T = 1,294.12
L = 2,545.53
R = 5,729.58

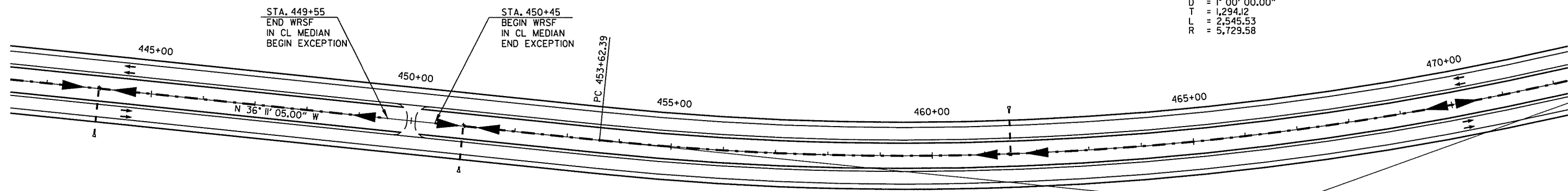

STA. 449+55
END WRSF
IN CL MEDIAN
BEGIN EXCEPTION

STA. 450+45
BEGIN WRSF
IN CL MEDIAN
END EXCEPTION

FC 453+62.39

PI 466+56.51

STA. 444+00 IN PLACE
18"X84' RC PIPE OUTLET
TYPE RM DROP INLET IN MED.
H=2'-3"
RETAIN

STA. 451+00 IN PLACE
18"X80' RC PIPE OUTLET
TYPE RM DROP INLET IN MED.
H=2'-2"
RETAIN

NOTE:
CONTRACTOR TO VERIFY EXISTING CROSSING UTILITIES PRIOR TO CONSTRUCTION. EXERCISE CARE AND PRECAUTION WHILE WORKING IN THESE AREAS.

PLAN SHEETS
STA. 413+00 - STA. 472+00

1/17/2014 11:03:05 AM P:\100038109\CADD\PAV\HWY63\17.dgn

STA. 474+00 IN PLACE
18"x88" RC PIPE OUTLET
TYPE RM DROP INLET IN MED.
H=2'-10"
RETAIN

STA. 496+70 IN PLACE
36"x208" RC PIPE CULVERT
30° RT. FWD. SKEW
TYPE RM DROP INLET IN MED.
H=4'-3"
RETAIN

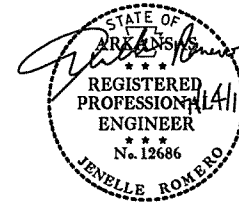

DATE REVISED	DATE FILMED	DATE REVISED	DATE FILMED	FED. RD. DIST. NO.	STATE	FED. AID PROJ. NO.	SHEET NO.	TOTAL SHEETS
				6	ARK.			
						JOB NO.	012196	65
PLAN SHEETS								

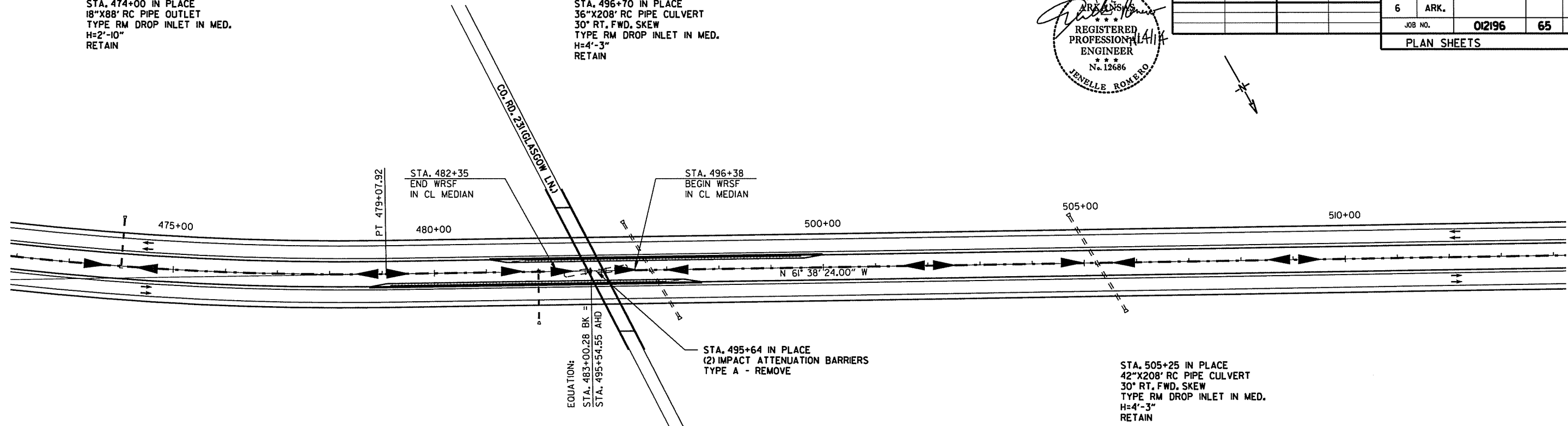

STA. 482+00 IN PLACE
18"x92" RC PIPE OUTLET
TYPE RM DROP INLET IN MED.
H=2'-10"
RETAIN

STA. 495+64 IN PLACE
(2) IMPACT ATTENUATION BARRIERS
TYPE A - REMOVE

STA. 505+25 IN PLACE
42"x208" RC PIPE CULVERT
30° RT. FWD. SKEW
TYPE RM DROP INLET IN MED.
H=4'-3"
RETAIN

GUARDRAIL	GUARDRAIL (TYPE A)	TERMINAL ANCHOR POST (TYPE 1)	GUARDRAIL TERMINAL (TYPE 2)
	LF	EA	EA
STA. 479+19 (BK.) - STA. 497+23 (AHD.) (RT. SHLDR.)	500	1	1
STA. 481+50 (BK.) - STA. 499+54 (AHD.) (LT. SHLDR.)	500	1	1

STA. 515+50 IN PLACE
DBL. 5'X4'X255' RC BOX CULVERT
45° LT. FWD. SKEW
TYPE TM DROP INLET IN MED.
H=2'-0"
RETAIN

STA. 522+75 IN PLACE
24"x210" RC PIPE CULVERT
30° RT. FWD. SKEW
TYPE RM DROP INLET IN MED.
H=3'-9"
RETAIN

STA. 535+10 IN PLACE
36"x212" RC PIPE CULVERT
30° RT. FWD. SKEW
TYPE RM DROP INLET IN MED.
H=4'-2"
RETAIN

STA. 540+30 IN PLACE
DBL. 36"x208" RC PIPE CULVERT
30° RT. FWD. SKEW
TYPE RM DROP INLET IN MED.
H=3'-2"
RETAIN

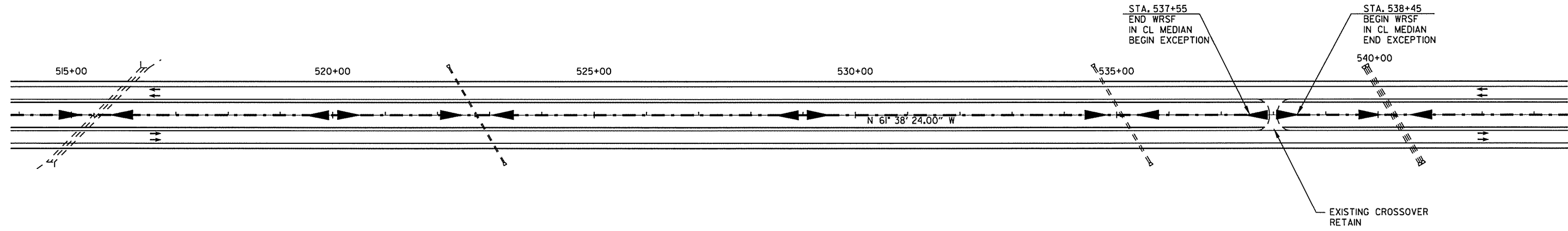

STA. 537+55
END WRSF
IN CL MEDIAN
BEGIN EXCEPTION

STA. 538+45
BEGIN WRSF
IN CL MEDIAN
END EXCEPTION

EXISTING CROSSOVER
RETAIN

NOTE:
CONTRACTOR TO VERIFY EXISTING CROSSING UTILITIES PRIOR TO CONSTRUCTION. EXERCISE CARE AND PRECAUTION WHILE WORKING IN THESE AREAS.

PLAN SHEETS
STA. 472+00 - STA. 543+00

7/17/2014 11:03:06 AM P:\100038109\CADD\PAV\HWY63-18.dgn

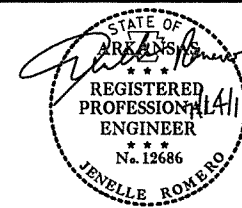

DATE REVISED	DATE FILMED	DATE REVISED	DATE FILMED	FED. RD. DIST. NO.	STATE	FED. AID PROJ. NO.	SHEET NO.	TOTAL SHEETS		
				6	ARK.					
							JOB NO.	012196	66	88

PLAN SHEETS

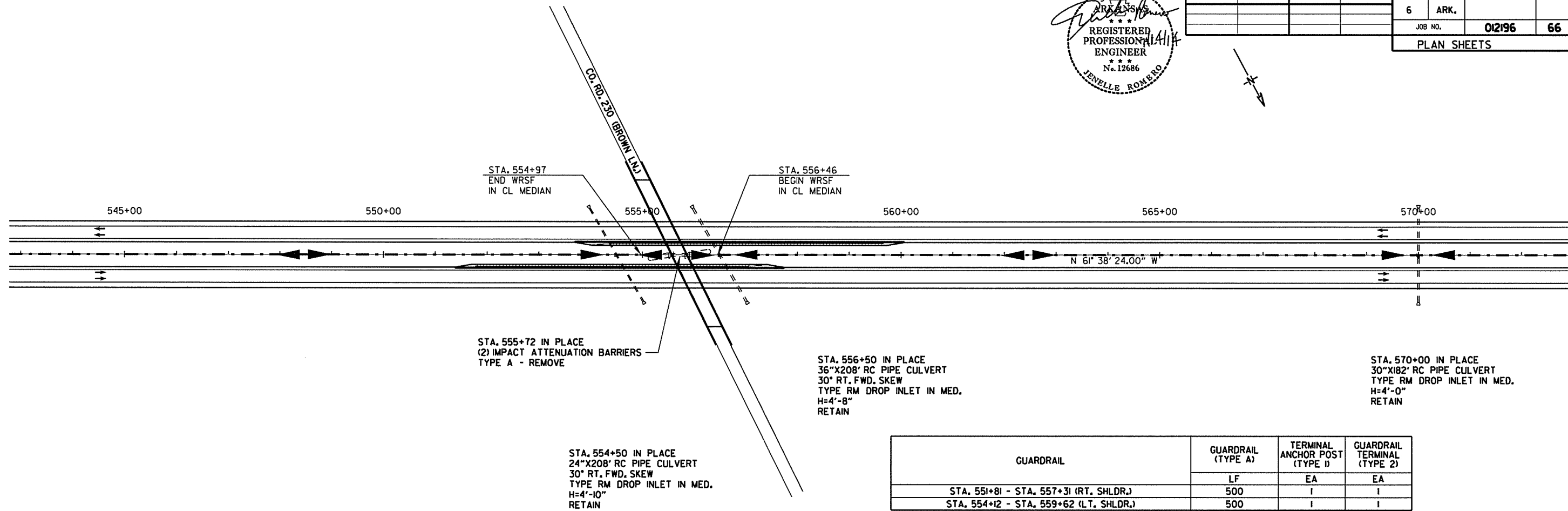

GUARDRAIL	GUARDRAIL (TYPE A)	TERMINAL ANCHOR POST (TYPE I)	GUARDRAIL TERMINAL (TYPE 2)
	LF	EA	EA
STA. 551+81 - STA. 557+31 (RT. SHLDR.)	500	I	I
STA. 554+12 - STA. 559+62 (LT. SHLDR.)	500	I	I

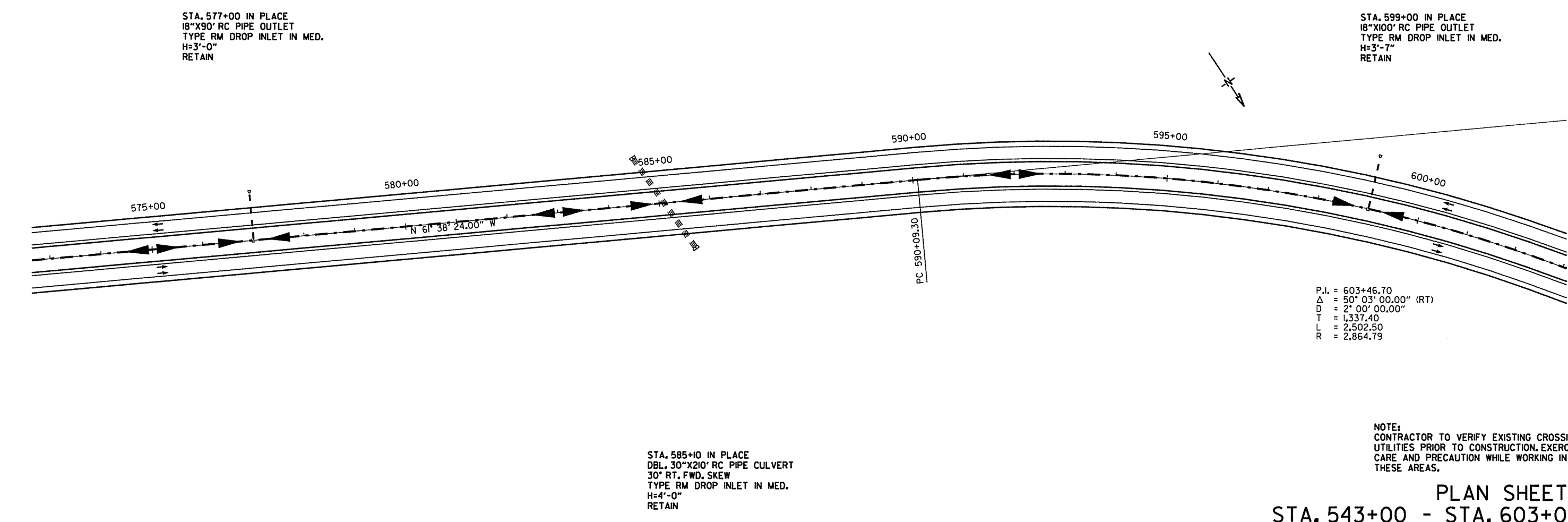

P.I. = 603+46.70
 Δ = 50° 03' 00.00" (RT)
D = 2° 00' 00.00"
T = 1,337.40
L = 2,502.50
R = 2,864.79

NOTE:
CONTRACTOR TO VERIFY EXISTING CROSSING UTILITIES PRIOR TO CONSTRUCTION, EXERCISE CARE AND PRECAUTION WHILE WORKING IN THESE AREAS.

PLAN SHEETS
STA. 543+00 - STA. 603+00

7/11/2014 11:03:08 AM P:\100038109\CADD\PAV\HWY63-19.dgn

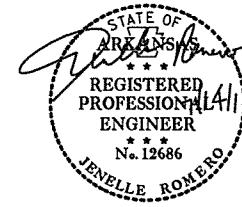

DATE REVISED	DATE FILMED	DATE REVISED	DATE FILMED	FED. RD. DIST. NO.	STATE	FED. AID PROJ. NO.	SHEET NO.	TOTAL SHEETS
				6	ARK.			
				JOB NO.		012196	67	88
PLAN SHEETS								

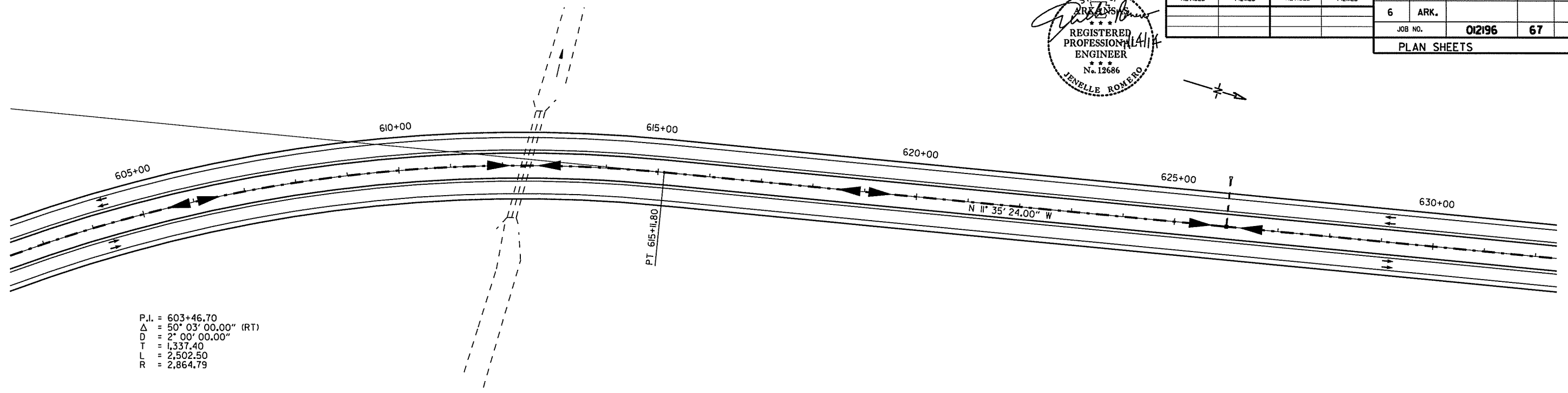

P.I. = 603+46.70
 Δ = 50° 03' 00.00" (RT)
 D = 2° 00' 00.00"
 T = 1,337.40
 L = 2,502.50
 R = 2,864.79

STA. 612+45 IN PLACE
 DBL. 8"X6"X205' RC BOX CULVERT
 15° LT. FWD. SKEW
 TYPE TM DROP INLET IN MED.
 H=2'-7"
 RETAIN

STA. 626+00 IN PLACE
 18"X88' RC PIPE OUTLET
 TYPE RM DROP INLET IN MED.
 H=3'-4"
 RETAIN

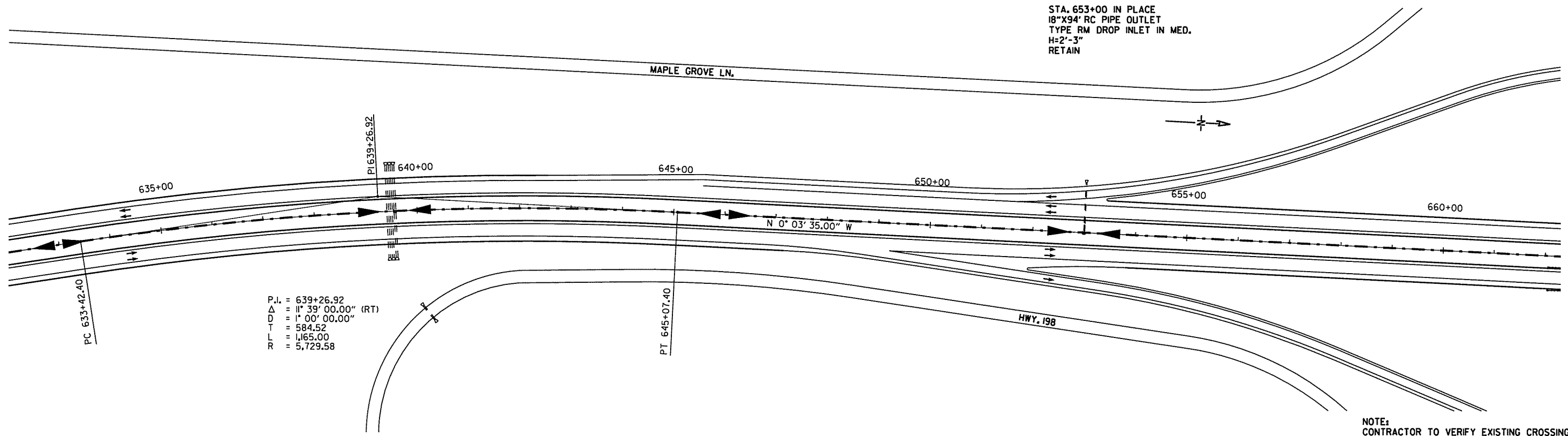

P.I. = 639+26.92
 Δ = 11° 39' 00.00" (RT)
 D = 1° 00' 00.00"
 T = 584.52
 L = 1,165.00
 R = 5,729.58

STA. 639+50 IN PLACE
 TRIPLE 36"X180' RC PIPE CULVERT
 TYPE RM DROP INLET IN MED.
 H=5'-3"
 RETAIN

STA. 653+00 IN PLACE
 18"X94' RC PIPE OUTLET
 TYPE RM DROP INLET IN MED.
 H=2'-3"
 RETAIN

NOTE:
 CONTRACTOR TO VERIFY EXISTING CROSSING UTILITIES PRIOR TO CONSTRUCTION. EXERCISE CARE AND PRECAUTION WHILE WORKING IN THESE AREAS.

PLAN SHEETS
 STA. 603+00 - STA. 662+00

7/17/2014 11:03:08 AM P:\100038109\CADD\FAV\HWY63-20.dgn

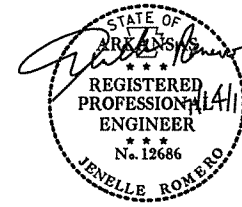

DATE REVISED	DATE FILMED	DATE REVISED	DATE FILMED	FED. RD. DIST. NO.	STATE	FED. AID PROJ. NO.	SHEET NO.	TOTAL SHEETS
				6	ARK.			
				JOB NO.		012196	68	88

PLAN SHEETS

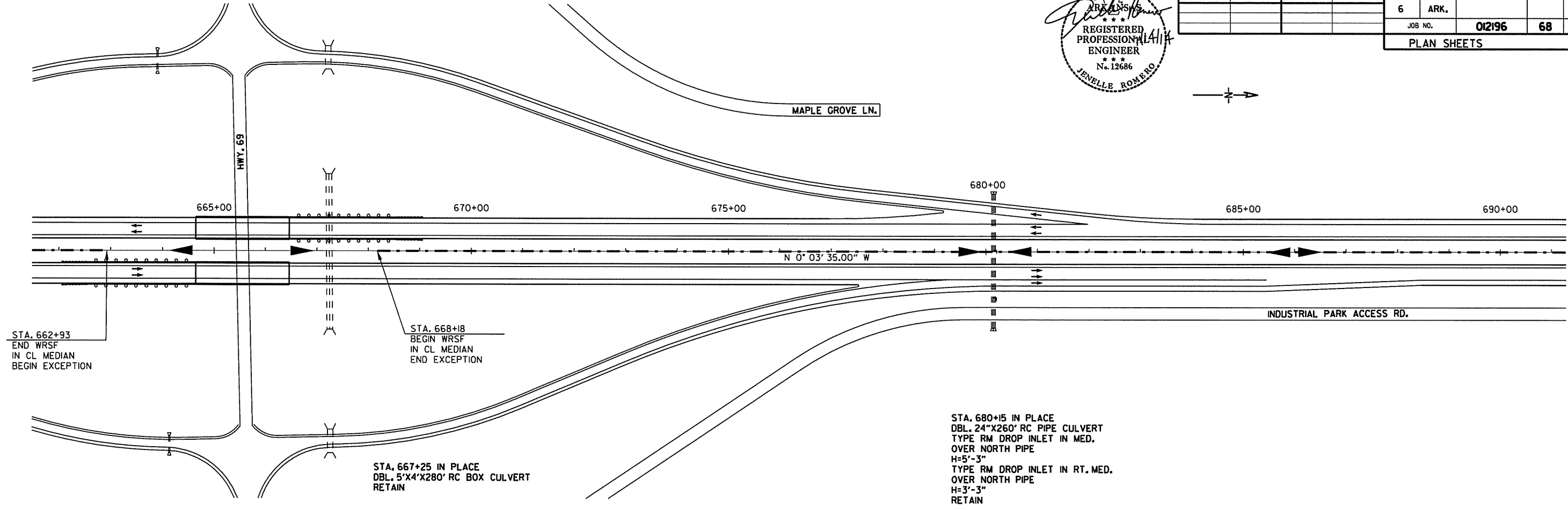

STA. 662+93
END WRSF
IN CL MEDIAN
BEGIN EXCEPTION

STA. 668+18
BEGIN WRSF
IN CL MEDIAN
END EXCEPTION

STA. 667+25 IN PLACE
DBL. 5'X4'X280' RC BOX CULVERT
RETAIN

STA. 680+15 IN PLACE
DBL. 24\"X260' RC PIPE CULVERT
TYPE RM DROP INLET IN MED.
OVER NORTH PIPE
H=5'-3\"
TYPE RM DROP INLET IN RT. MED.
OVER NORTH PIPE
H=3'-3\"
RETAIN

STA. 718+25 IN PLACE
TRIPLE 7'X6'X198' RC BOX CULVERT
15' L.T. FWD. SKEW
RETAIN

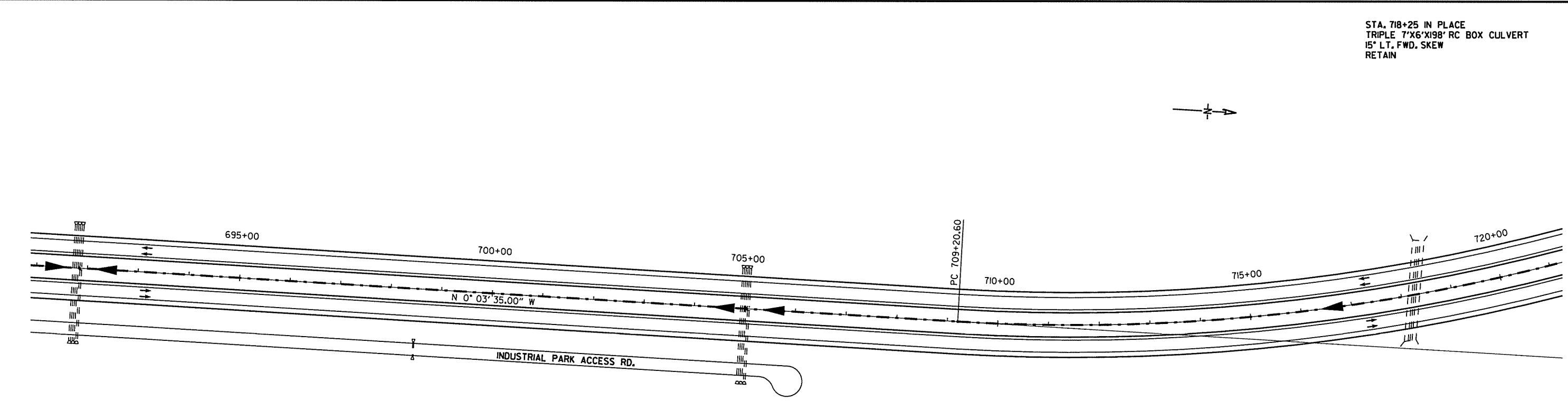

STA. 691+80 IN PLACE
TRIPLE 36\"X230' RC PIPE CULVERT
TYPE RM DROP INLET IN MED.
OVER NORTH PIPE
H=5'-6\"
RETAIN

STA. 705+00 IN PLACE
TRIPLE 36\"X224' RC PIPE CULVERT
TYPE RM DROP INLET IN MED.
OVER NORTH PIPE
H=5'-0\"
RETAIN

NOTE:
CONTRACTOR TO VERIFY EXISTING CROSSING UTILITIES PRIOR TO CONSTRUCTION. EXERCISE CARE AND PRECAUTION WHILE WORKING IN THESE AREAS.

PLAN SHEETS
STA. 662+00 - STA. 721+00

7/11/2014 10:03:08 AM

P:\10003809\CADD\PAV\HWY63-21.dwt

STA. 729+00 IN PLACE
 24"X88' RC PIPE OUTLET
 TYPE RM DROP INLET IN MED.
 H=3'-9"
 RETAIN

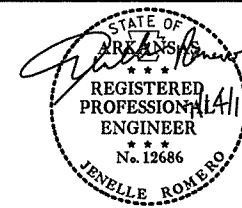

DATE REVISED	DATE FILMED	DATE REVISED	DATE FILMED	FED. RD. DIST. NO.	STATE	FED. AID PROJ. NO.	SHEET NO.	TOTAL SHEETS	
				6	ARK.				
							JOB NO. 012196	69	88

P.J. = 725+33.45
 Δ = 45° 47' 00.00" (LT)
 D = 1' 30' 00.04"
 T = 1,612.85
 L = 3,052.20
 R = 3,819.69

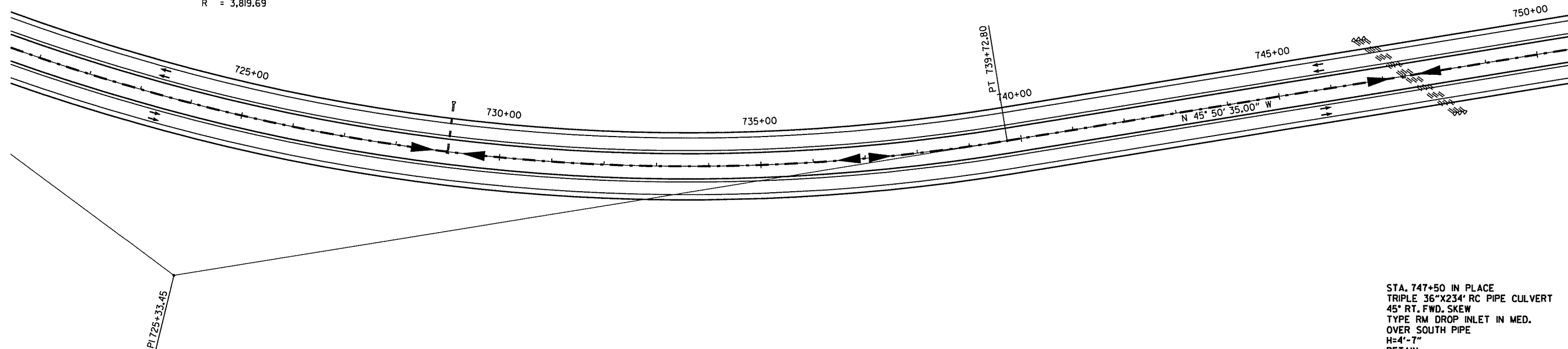

STA. 747+50 IN PLACE
 TRIPLE 36"X234' RC PIPE CULVERT
 45° RT. FWD. SKEW
 TYPE RM DROP INLET IN MED.
 OVER SOUTH PIPE
 H=4'-7"
 RETAIN

STA. 779+50 IN PLACE
 DBL. 30"X252' RC PIPE CULVERT
 45° LT. FWD. SKEW
 TYPE RM DROP INLET IN MED.
 OVER SOUTH PIPE
 H=4'-4"
 RETAIN

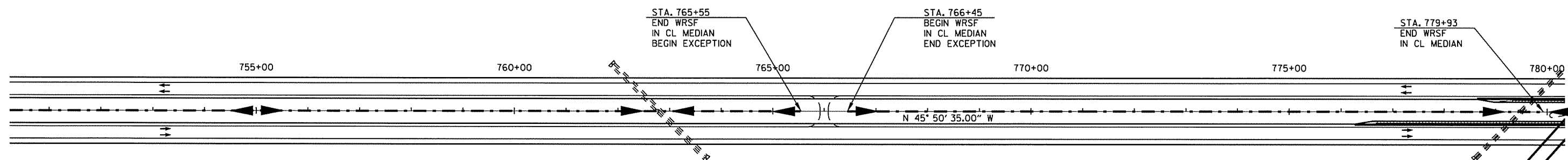

STA. 765+55
 END WRSF
 IN CL MEDIAN
 BEGIN EXCEPTION

STA. 766+45
 BEGIN WRSF
 IN CL MEDIAN
 END EXCEPTION

STA. 779+93
 END WRSF
 IN CL MEDIAN

STA. 762+80 IN PLACE
 DBL. 36"X252' RC PIPE CULVERT
 45° RT. FWD. SKEW
 TYPE RM DROP INLET IN MED.
 OVER SOUTH PIPE
 H=5'-3"
 RETAIN

NOTE:
 CONTRACTOR TO VERIFY EXISTING CROSSING
 UTILITIES PRIOR TO CONSTRUCTION, EXERCISE
 CARE AND PRECAUTION WHILE WORKING IN
 THESE AREAS.

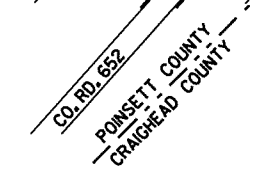

PLAN SHEETS
 STA. 721+00 - STA. 780+00

7/11/2014 11:03:09 AM P:\00038109\CADD\PAV\HWY63-22.dgn

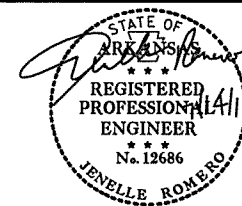

DATE REVISED	DATE FILMED	DATE REVISED	DATE FILMED	FED. RD. DIST. NO.	STATE	FED. AID PROJ. NO.	SHEET NO.	TOTAL SHEETS
				6	ARK.			
						JOB NO.	012196	70 88

PLAN SHEETS

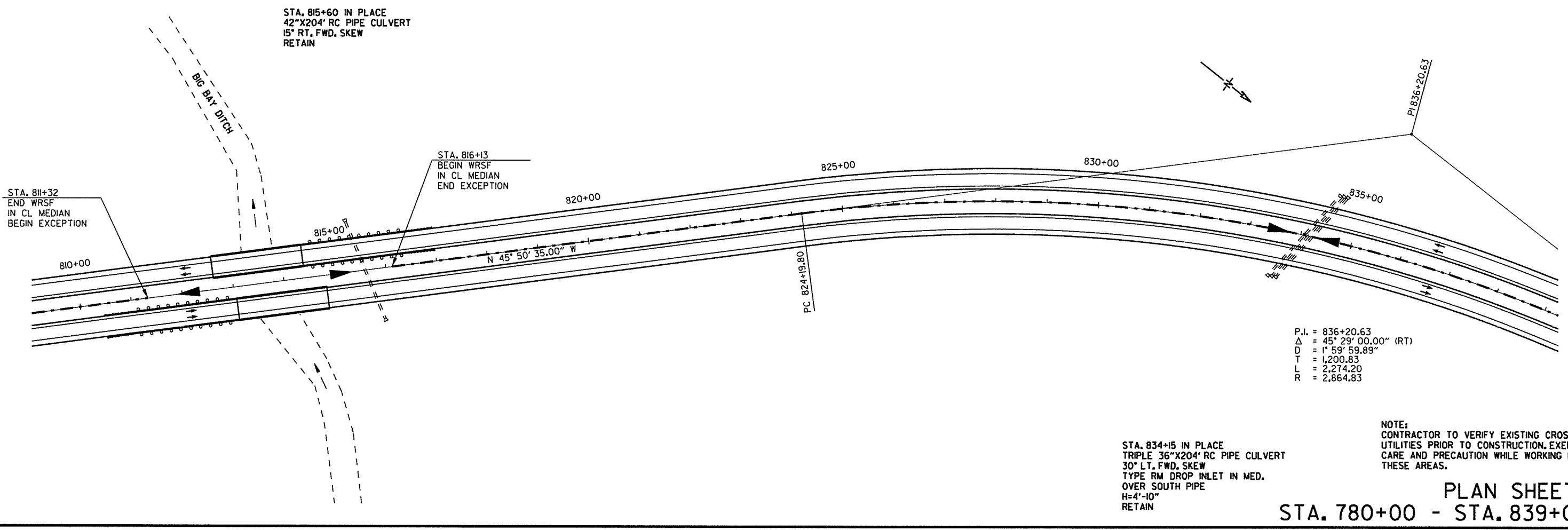
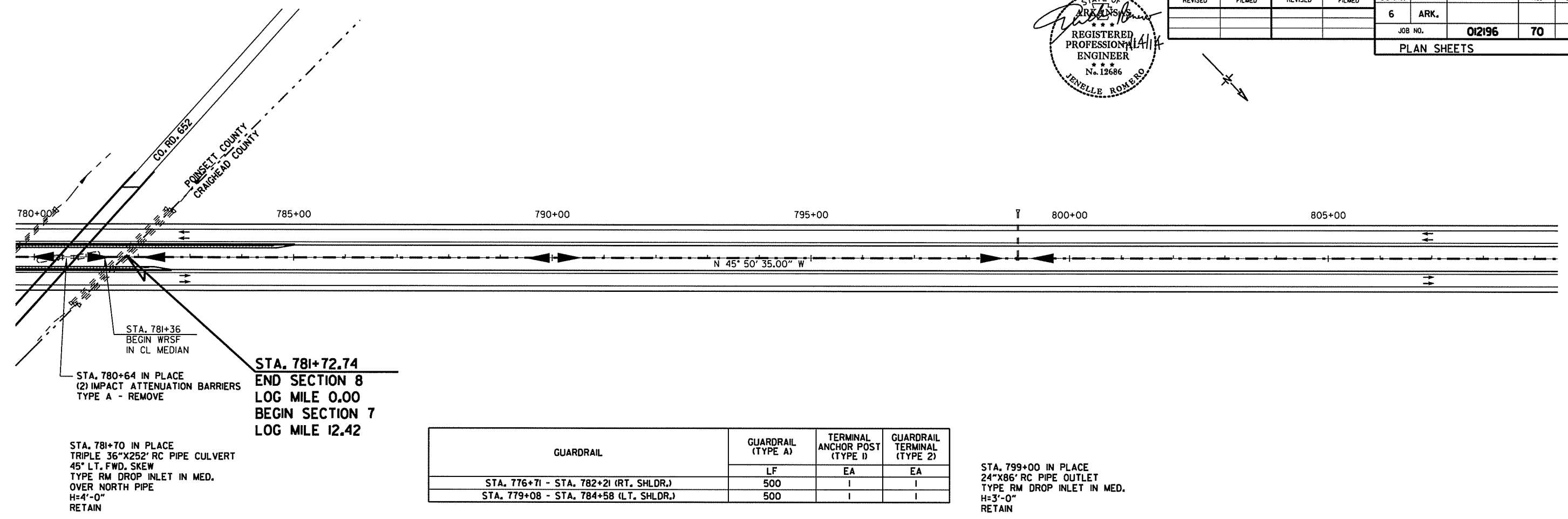

PLAN SHEETS
 STA. 780+00 - STA. 839+00

7/11/2014 11:03:10 AM P:\000038105\CADD\PAV\HWY63-23.dgn

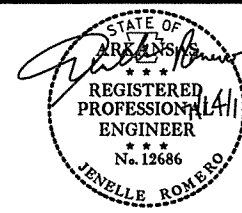

DATE REVISED	DATE FILMED	DATE REVISED	DATE FILMED	FED. RD. DIST. NO.	STATE	FED. AID PROJ. NO.	SHEET NO.	TOTAL SHEETS
				6	ARK.			
							JOB NO.	
							012196	71
							88	

PLAN SHEETS

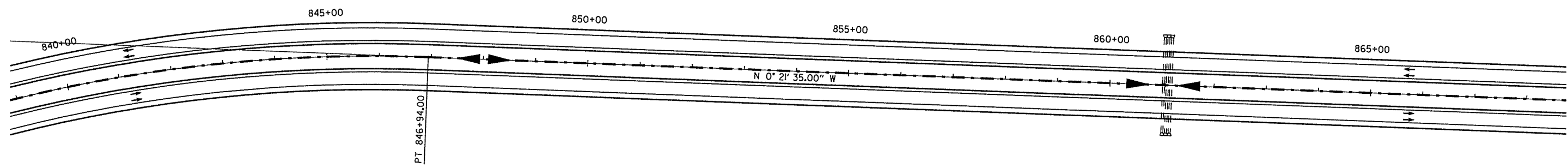

STA. 861+10 IN PLACE
 TRIPLE 42"X182" RC PIPE CULVERT
 TYPE RM DROP INLET IN MED.
 OVER SOUTH PIPE
 H=6'-9"
 RETAIN

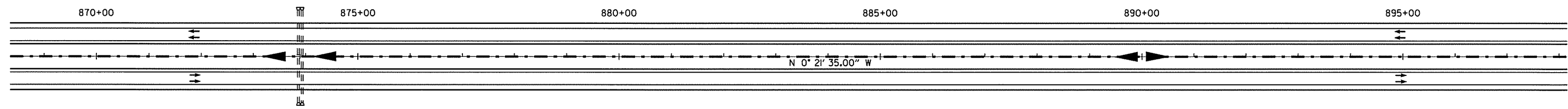

STA. 873+90 IN PLACE
 DBL. 36"X178" RC PIPE CULVERT
 TYPE RM DROP INLET IN MED.
 OVER SOUTH PIPE
 H=5'-3"
 RETAIN

NOTE:
 CONTRACTOR TO VERIFY EXISTING CROSSING UTILITIES PRIOR TO CONSTRUCTION, EXERCISE CARE AND PRECAUTION WHILE WORKING IN THESE AREAS.

PLAN SHEETS
 STA. 839+00 - STA. 898+00

7/17/2014 11:03:10 AM

P:\100038109\CAADD\PAV\HWY63-24.dgn

STA. 900+25 IN PLACE
 DBL. 36"x174' RC PIPE CULVERT
 TYPE RM DROP INLET IN MED.
 OVER SOUTH PIPE
 H=4'-10"
 RETAIN

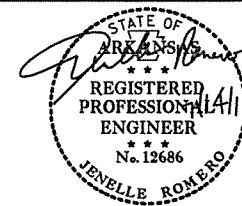

DATE REVISED	DATE FILMED	DATE REVISED	DATE FILMED	FED. RD. DIST. NO.	STATE	FED. AID PROJ. NO.	SHEET NO.	TOTAL SHEETS
				6	ARK.			
JOB NO. 012196							72	88

PLAN SHEETS

STA. 927+10 IN PLACE
 TRIPLE 36"x170' RC PIPE CULVERT
 TYPE RM DROP INLET IN MED.
 OVER NORTH PIPE
 H=4'-5"
 RETAIN

STA. 926+39 IN PLACE
 (2) IMPACT ATTENUATION BARRIERS
 TYPE A - REMOVE

STA. 925+63
 END WRSF
 IN CL MEDIAN

STA. 927+15
 BEGIN WRSF
 IN CL MEDIAN

CO. RD. 638 (W. ROBINSON ST.)

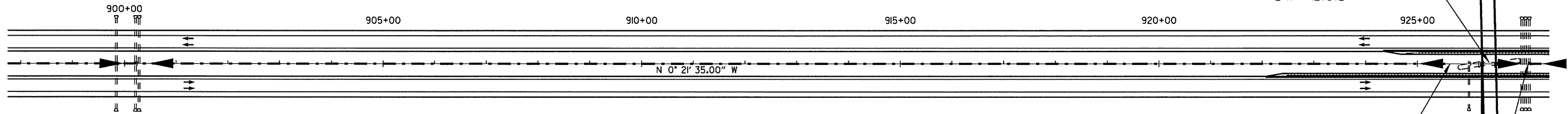

GUARDRAIL	GUARDRAIL (TYPE A)	TERMINAL ANCHOR POST (TYPE I)	GUARDRAIL TERMINAL (TYPE 2)
STA. 922+50 - STA. 928+00 (RT. SHLDR.)	LF	EA	EA
STA. 924+78 - STA. 930+28 (LT. SHLDR.)	500	I	I
	500	I	I

STA. 926+00 IN PLACE
 24"x82' RC PIPE OUTLET
 TYPE RM DROP INLET IN MED.
 H=3'-0"
 RETAIN

STA. 899+85 IN PLACE
 36"x174' RC PIPE CULVERT
 RETAIN

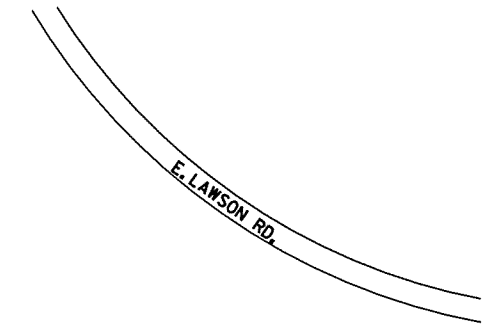
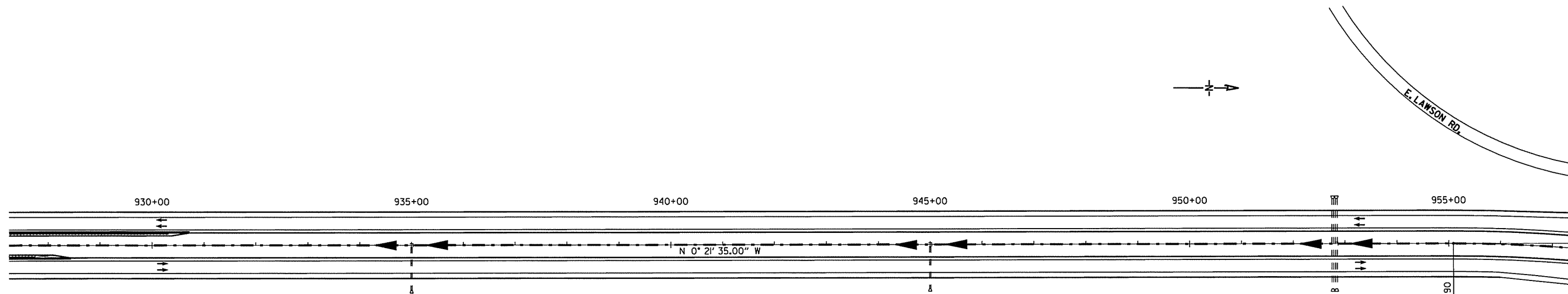

PC 955+08.90

STA. 952+80 IN PLACE
 DBL. 36"x174' RC PIPE CULVERT
 TYPE RM DROP INLET IN MED.
 OVER NORTH PIPE
 H=4'-6"
 RETAIN

NOTE:
 CONTRACTOR TO VERIFY EXISTING CROSSING UTILITIES PRIOR TO CONSTRUCTION, EXERCISE CARE AND PRECAUTION WHILE WORKING IN THESE AREAS.

STA. 935+00 IN PLACE
 24"x84' RC PIPE OUTLET
 TYPE RM DROP INLET IN MED.
 H=3'-0"
 RETAIN

STA. 945+00 IN PLACE
 24"x82' RC PIPE OUTLET
 TYPE RM DROP INLET IN MED.
 H=3'-0"
 RETAIN

PLAN SHEETS
 STA. 898+00 - STA. 957+00

7/11/2014 11:03:12 AM P:\100038109\CADD\PAV\HWY63-25.dgn

STA. 962+00 IN PLACE
18"x94" RC PIPE OUTLET
TYPE R DROP INLET IN MED.
H=4'-0"
RETAIN

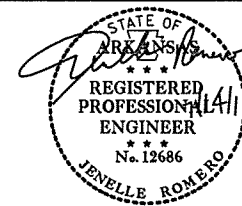

DATE REVISED	DATE FILMED	DATE REVISED	DATE FILMED	FED. RD. DIST. NO.	STATE	FED. AID PROJ. NO.	SHEET NO.	TOTAL SHEETS
				6	ARK.			
JOB NO. 02196							73	88

PLAN SHEETS

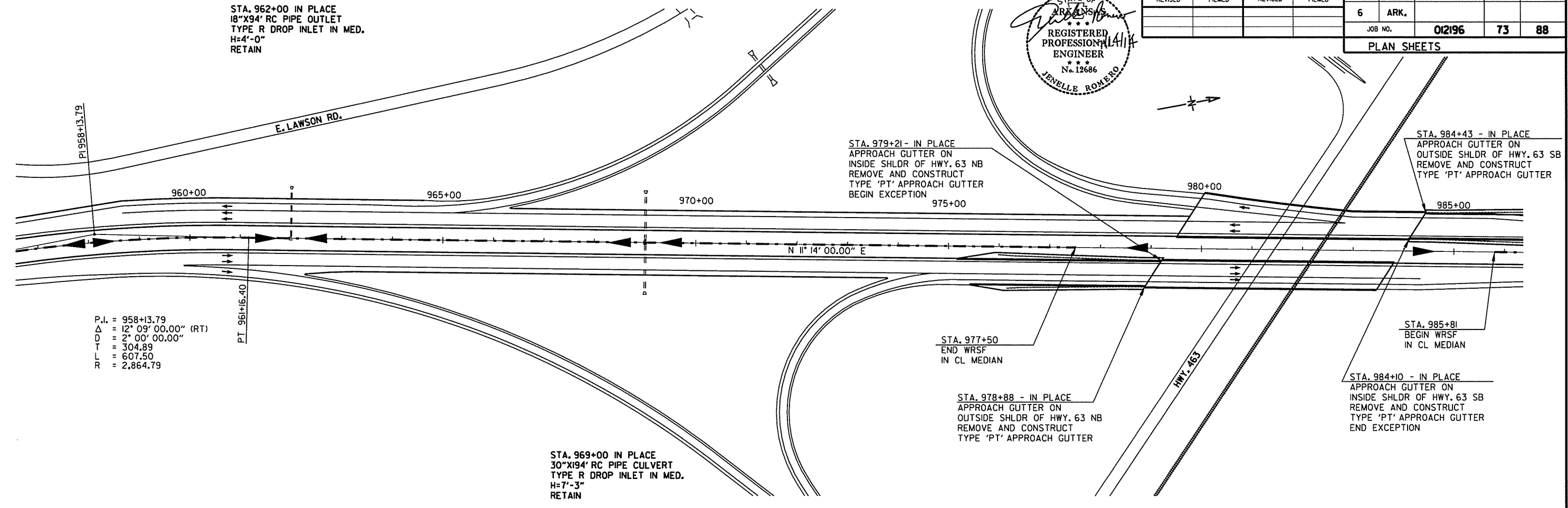

P.I. = 958+13.79
Δ = 12° 09' 00.00" (RT)
D = 2° 00' 00.00"
T = 304.89
L = 607.50
R = 2,864.79

STA. 969+00 IN PLACE
30"x194" RC PIPE CULVERT
TYPE R DROP INLET IN MED.
H=7'-3"
RETAIN

STA. 979+21 - IN PLACE
APPROACH GUTTER ON
INSIDE SHLDR OF HWY. 63 NB
REMOVE AND CONSTRUCT
TYPE 'PT' APPROACH GUTTER
BEGIN EXCEPTION

STA. 977+50
END WRSF
IN CL MEDIAN

STA. 978+88 - IN PLACE
APPROACH GUTTER ON
OUTSIDE SHLDR OF HWY. 63 NB
REMOVE AND CONSTRUCT
TYPE 'PT' APPROACH GUTTER

STA. 984+43 - IN PLACE
APPROACH GUTTER ON
OUTSIDE SHLDR OF HWY. 63 SB
REMOVE AND CONSTRUCT
TYPE 'PT' APPROACH GUTTER

STA. 985+81
BEGIN WRSF
IN CL MEDIAN

STA. 984+10 - IN PLACE
APPROACH GUTTER ON
INSIDE SHLDR OF HWY. 63 SB
REMOVE AND CONSTRUCT
TYPE 'PT' APPROACH GUTTER
END EXCEPTION

GUARDRAIL	GUARDRAIL (TYPE A)	TERMINAL ANCHOR POST (TYPE I)	GUARDRAIL TERMINAL (TYPE 2)	THREE BEAM GUARDRAIL TERMINAL
	LF	EA	EA	EA
STA. 976+02 - STA. 979+02 (INSIDE SHLDR. OF NB LANES)	250			
STA. 978+69 - STA. 981+19 (OUTSIDE SHLDR. OF NB LANES)	200			
STA. 984+29 - STA. 987+29 (INSIDE SHLDR. OF SB LANES)	250			
STA. 984+62 - STA. 987+12 (OUTSIDE SHLDR. OF SB LANES)	200			

STA. 1013+00 IN PLACE
18"x90" RC PIPE OUTLET
TYPE R DROP INLET IN MED.
H=3'-0"
RETAIN

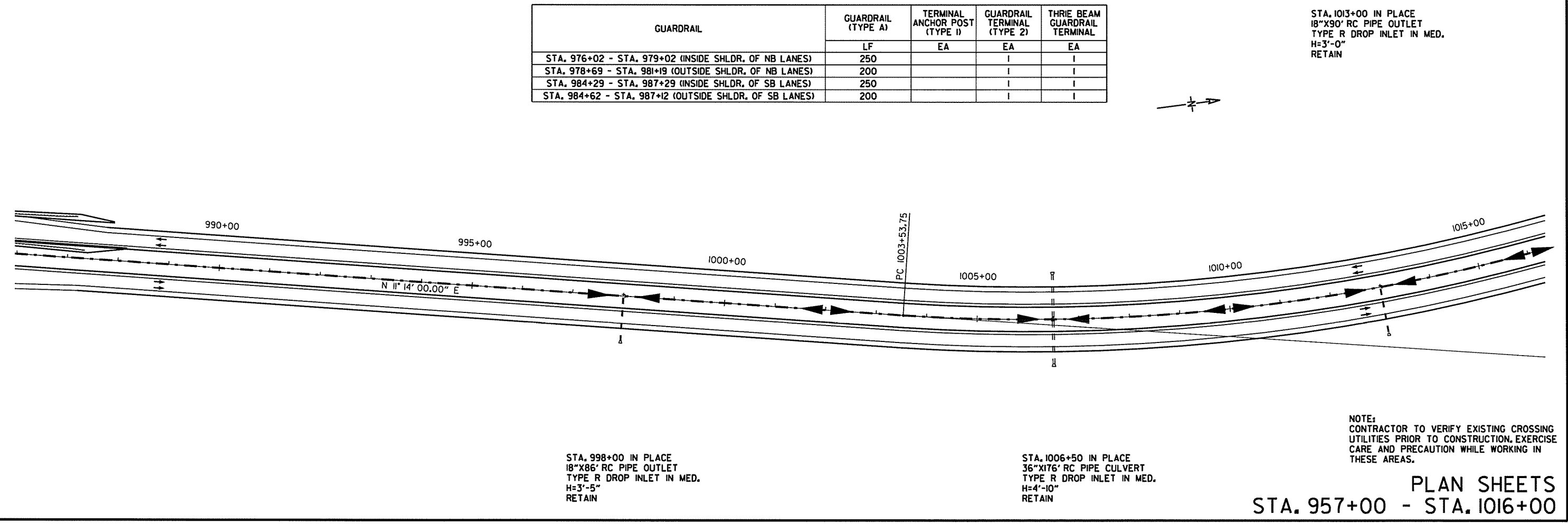

STA. 998+00 IN PLACE
18"x86" RC PIPE OUTLET
TYPE R DROP INLET IN MED.
H=3'-5"
RETAIN

STA. 1006+50 IN PLACE
36"x176" RC PIPE CULVERT
TYPE R DROP INLET IN MED.
H=4'-10"
RETAIN

NOTE:
CONTRACTOR TO VERIFY EXISTING CROSSING
UTILITIES PRIOR TO CONSTRUCTION, EXERCISE
CARE AND PRECAUTION WHILE WORKING IN
THESE AREAS.

PLAN SHEETS
STA. 957+00 - STA. 1016+00

7/17/2014 11:03:13 AM P:\100038109\CADD\PAV\HWY63-26.dgn

STA. 1019+75 IN PLACE
42"x180' RC PIPE CULVERT
8° LT. FWD. SKEW
TYPE R DROP INLET IN MED.
H=5'-6"
RETAIN

STA. 1027+00 IN PLACE
18"x86' RC PIPE OUTLET
TYPE R DROP INLET IN MED.
H=3'-6"
RETAIN

STA. 1033+60 IN PLACE
DBL. 36"x202' RC PIPE CULVERT
31° 30' LT. FWD. SKEW
TYPE R DROP INLET IN MED.
OVER SOUTH PIPE
H=4'-1"
RETAIN

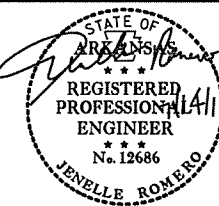

DATE REVISED	DATE FILMED	DATE REVISED	DATE FILMED	FED. RD. DIST. NO.	STATE	FED. AID PROJ. NO.	SHEET NO.	TOTAL SHEETS
				6	ARK.			
						JOB NO.	012196	74
PLAN SHEETS								

P.I. = 1027+90.31
Δ = 65° 04' 00.00" (LT)
D = 1' 30' 00.00"
T = 2,436.56
L = 4,337.78
R = 3,819.72

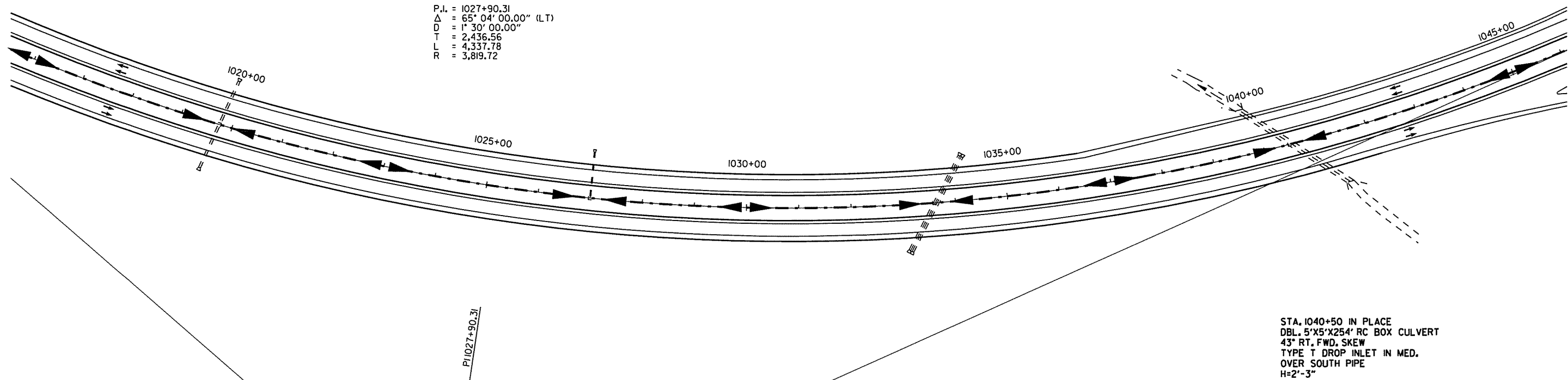

STA. 1040+50 IN PLACE
DBL. 5'x5'x254' RC BOX CULVERT
43° RT. FWD. SKEW
TYPE T DROP INLET IN MED.
OVER SOUTH PIPE
H=2'-3"
RETAIN

STA. 1049+00 IN PLACE
18"x90' RC PIPE OUTLET
TYPE R DROP INLET IN MED.
H=5'-1"
RETAIN

STA. 1057+00 IN PLACE
18"x92' RC PIPE OUTLET
TYPE R DROP INLET IN MED.
H=3'-4"
RETAIN

STA. 1074+00 IN PLACE
18"x86' RC PIPE OUTLET
TYPE R DROP INLET IN MED.
H=2'-6"
RETAIN

STA. 1061+41 IN PLACE
(2) IMPACT ATTENUATION BARRIERS
TYPE A - REMOVE

STA. 1060+65
END WRSF
IN CL MEDIAN

STA. 1062+17
BEGIN WRSF
IN CL MEDIAN

STA. 1064+75 IN PLACE
36"x170' RC PIPE CULVERT
TYPE R DROP INLET IN MED.
H=3'-10"
RETAIN

NOTE:
CONTRACTOR TO VERIFY EXISTING CROSSING UTILITIES PRIOR TO CONSTRUCTION. EXERCISE CARE AND PRECAUTION WHILE WORKING IN THESE AREAS.

GUARDRAIL	GUARDRAIL (TYPE A)	TERMINAL ANCHOR POST (TYPE 1)	GUARDRAIL TERMINAL (TYPE 2)
STA. 1057+52 - STA. 1063+02 (RT. SHLDR.)	500	EA	EA
STA. 1059+80 - STA. 1065+30 (LT. SHLDR.)	500	I	I

PLAN SHEETS
STA. 1016+00 - STA. 1075+00

7/11/2014 10:31:17 AM P:\00038109\CADD\PAV\HWY63-27.dgn

DATE REVISED	DATE FILMED	DATE REVISED	DATE FILMED	FED. RD. DIST. NO.	STATE	FED. AID PROJ. NO.	SHEET NO.	TOTAL SHEETS
				6	ARK.			
						JOB NO.	012196	75 88

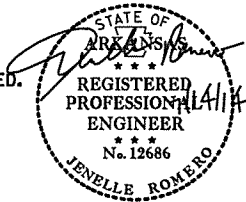

PLAN SHEETS

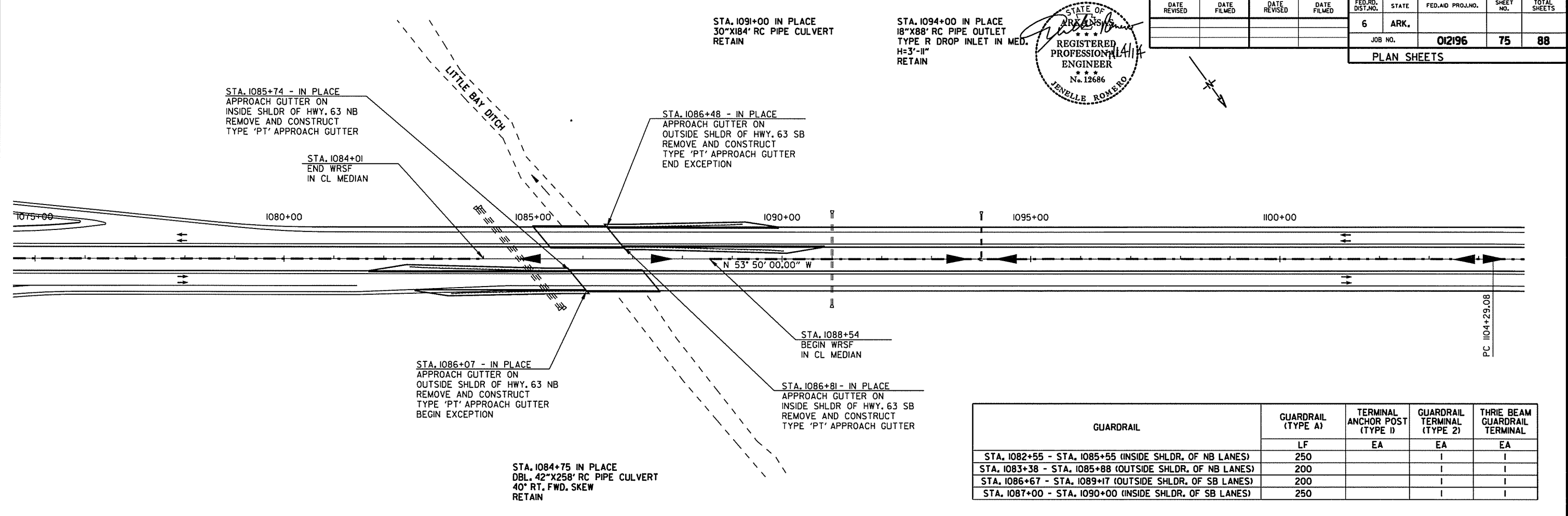

GUARDRAIL	GUARDRAIL (TYPE A)	TERMINAL ANCHOR POST (TYPE 1)	GUARDRAIL TERMINAL (TYPE 2)	THREE BEAM GUARDRAIL TERMINAL
STA. 1082+55 - STA. 1085+55 (INSIDE SHLDR. OF NB LANES)	250	EA	EA	EA
STA. 1083+38 - STA. 1085+88 (OUTSIDE SHLDR. OF NB LANES)	200			
STA. 1086+67 - STA. 1089+17 (OUTSIDE SHLDR. OF SB LANES)	200			
STA. 1087+00 - STA. 1090+00 (INSIDE SHLDR. OF SB LANES)	250			

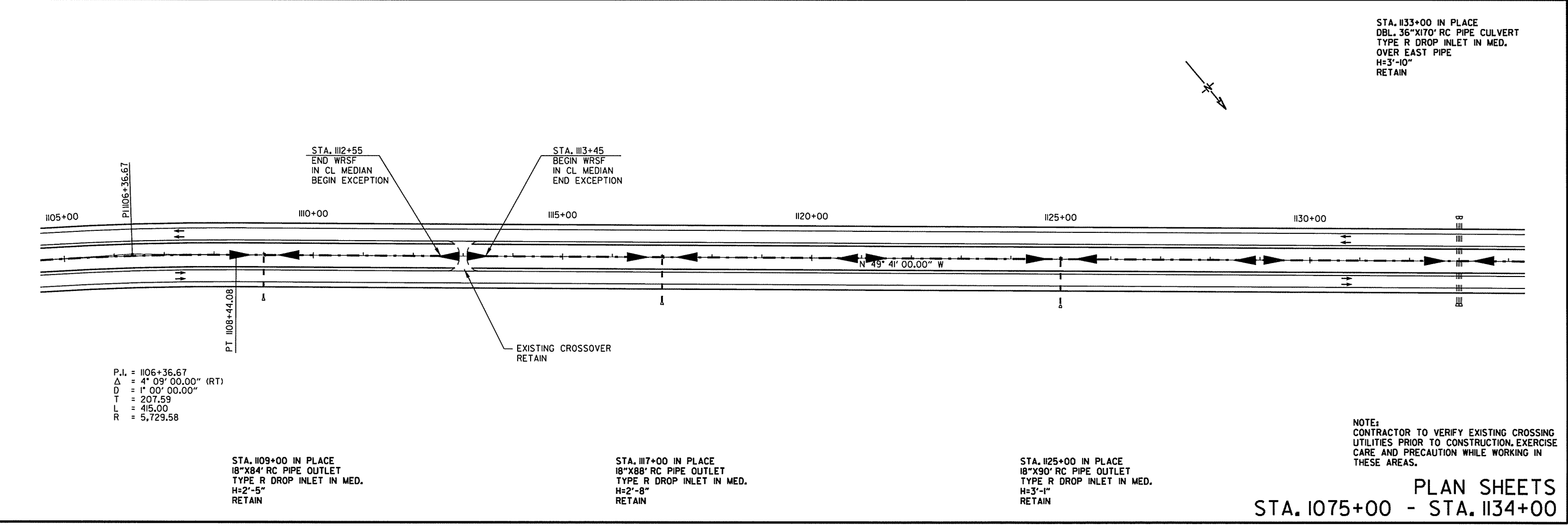

P.I. = 1106+36.67
 Δ = 4° 09' 00.00" (RT)
D = 1' 00' 00.00"
T = 207.59
L = 415.00
R = 5,729.58

NOTE:
CONTRACTOR TO VERIFY EXISTING CROSSING UTILITIES PRIOR TO CONSTRUCTION, EXERCISE CARE AND PRECAUTION WHILE WORKING IN THESE AREAS.

PLAN SHEETS
STA. 1075+00 - STA. 1134+00

7/17/2014 11:03:18 AM P:\00038109\CAADD\PAV\HWY63-28.dgn

STA. 1142+80 IN PLACE
 DBL. 36"X220" RC PIPE CULVERT
 35° LT. FWD. SKEW
 TYPE R DROP INLET IN MED.
 H=4'-7"
 RETAIN

STA. 1152+00 IN PLACE
 18"X84" RC PIPE OUTLET
 TYPE R DROP INLET IN MED.
 H=2'-6"
 RETAIN

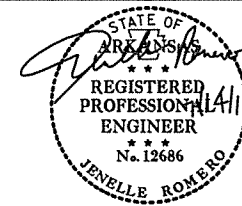

DATE REVISED	DATE FILMED	DATE REVISED	DATE FILMED	FED. RD. DIST. NO.	STATE	FED. AID PROJ. NO.	SHEET NO.	TOTAL SHEETS
				6	ARK.			
JOB NO. 012196							76	88

STA. 1162+00 IN PLACE
 18"X84" RC PIPE OUTLET
 TYPE R DROP INLET IN MED.
 H=2'-6"
 RETAIN

PLAN SHEETS

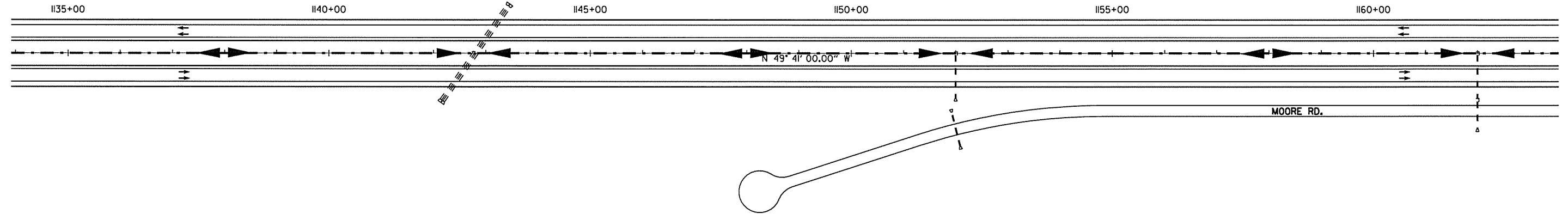

STA. 1163+75 IN PLACE
 DBL. 5'X3'X220' RC BOX CULVERT
 RETAIN

STA. 1172+00 IN PLACE
 18"X84' RC PIPE OUTLET
 TYPE R DROP INLET IN MED.
 H=2'-6"
 RETAIN

STA. 1177+90 IN PLACE
 DBL. 5'X4'X334' RC BOX CULVERT
 48° 31' LT. FWD. SKEW
 RETAIN

STA. 1193+00 IN PLACE
 18"X88' RC PIPE OUTLET
 TYPE R DROP INLET IN MED.
 H=2'-6"
 RETAIN

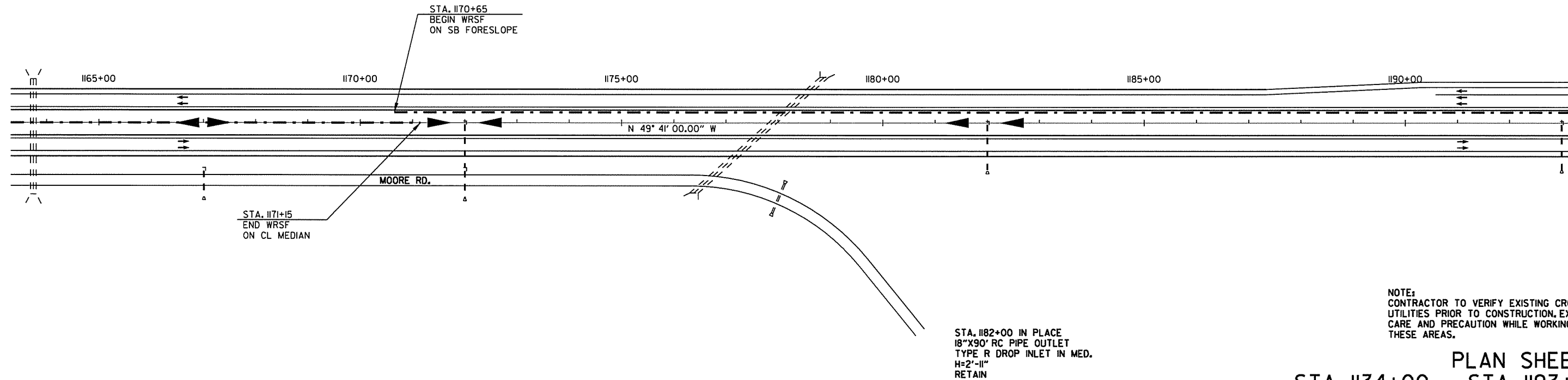

STA. 1182+00 IN PLACE
 18"X90' RC PIPE OUTLET
 TYPE R DROP INLET IN MED.
 H=2'-11"
 RETAIN

NOTE:
 CONTRACTOR TO VERIFY EXISTING CROSSING UTILITIES PRIOR TO CONSTRUCTION. EXERCISE CARE AND PRECAUTION WHILE WORKING IN THESE AREAS.

PLAN SHEETS
 STA. 1134+00 - STA. 1193+00

7/17/2014 11:03:15 AM P:\00038109\CA00\PAV\HW\63-29.dgn

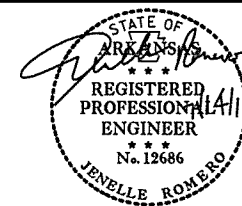

DATE REVISED	DATE FILMED	DATE REVISED	DATE FILMED	FED. RD. DIST. NO.	STATE	FED. AID PROJ. NO.	SHEET NO.	TOTAL SHEETS
				6	ARK.			
JOB NO. 012196							77	88

PLAN SHEETS

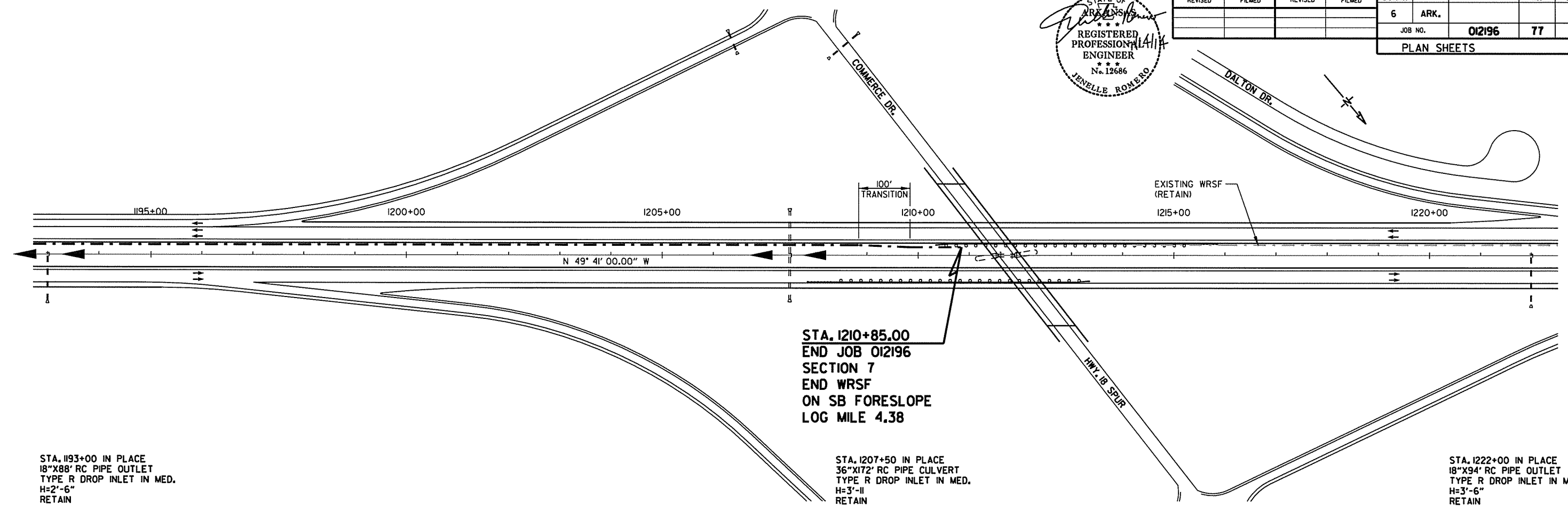

STA. 1210+85.00
 END JOB 012196
 SECTION 7
 END WRSF
 ON SB FORESLOPE
 LOG MILE 4.38

STA. 1193+00 IN PLACE
 18"X88' RC PIPE OUTLET
 TYPE R DROP INLET IN MED.
 H=2'-6"
 RETAIN

STA. 1207+50 IN PLACE
 36"X172' RC PIPE CULVERT
 TYPE R DROP INLET IN MED.
 H=3'-11"
 RETAIN

STA. 1222+00 IN PLACE
 18"X94' RC PIPE OUTLET
 TYPE R DROP INLET IN MED.
 H=3'-6"
 RETAIN

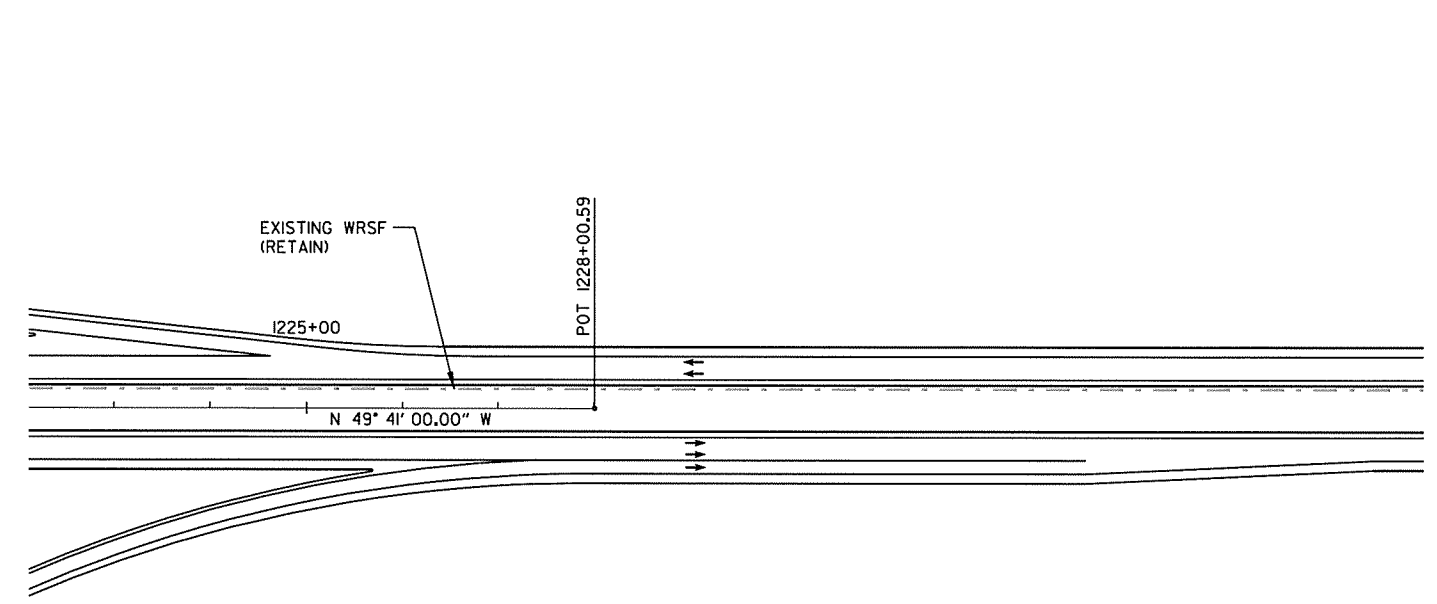

NOTE:
 CONTRACTOR TO VERIFY EXISTING CROSSING UTILITIES PRIOR TO CONSTRUCTION, EXERCISE CARE AND PRECAUTION WHILE WORKING IN THESE AREAS.

PLAN SHEETS
 STA. 1193+00 - STA. 1228+00.59

7/17/2014 11:03:19 AM P:\00038109\CAADD\PAV\HWY63-30.dgn

DATE REVISED	DATE FILMED	DATE REVISED	DATE FILMED	FED. ROAD DIST. NO.	STATE	FED. AID PROJ. NO.	SHEET NO.	TOTAL SHEETS
				6	ARK.		78	
JOB NO.							TYPE PT GUTTERS 55035	

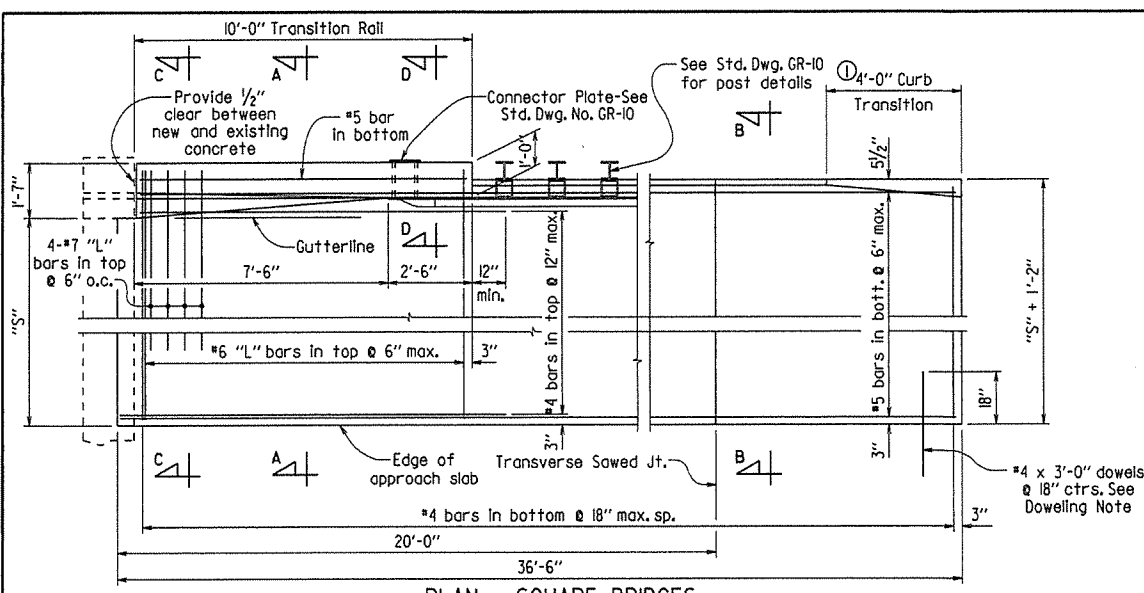

PLAN - SQUARE BRIDGES
 $\frac{3}{8}'' = 1'-0''$ "S" = Distance from gutterline to edge of approach slab.

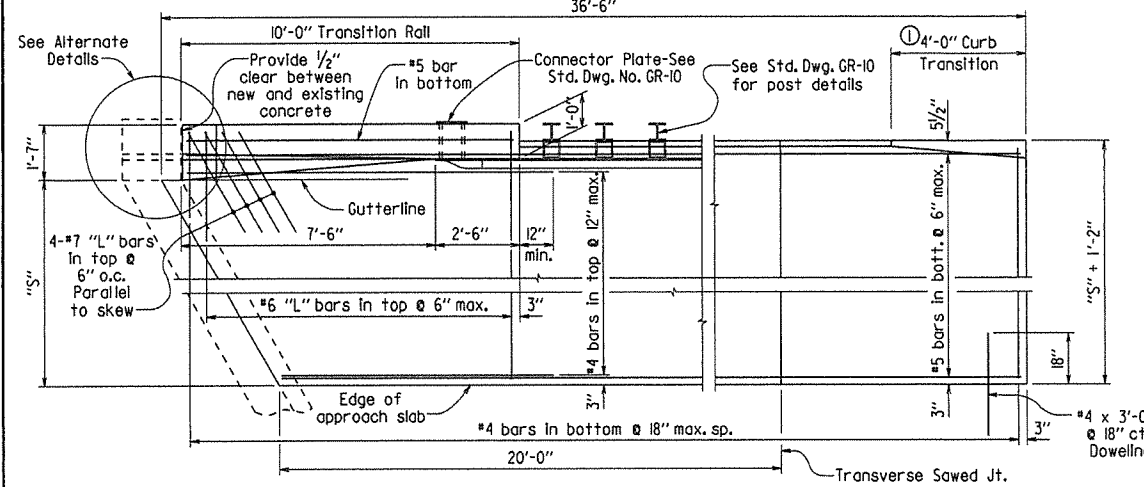

PLAN - SKEWED BRIDGES
 $\frac{3}{8}'' = 1'-0''$

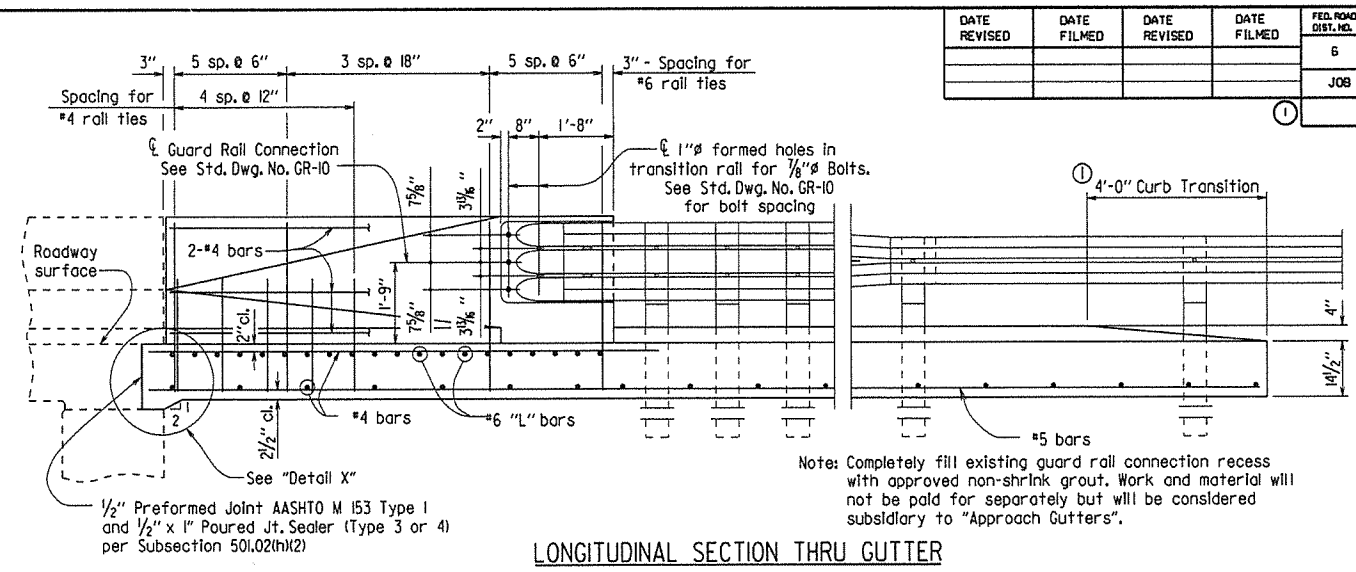

LONGITUDINAL SECTION THRU GUTTER
 $\frac{1}{2}'' = 1'-0''$

Construct curb with height-transition as shown if drop inlet is not used at end of gutter.
 Construct curb full height (no height-transition) if drop inlet is used at end of gutter. Curb height transition placed on drop inlet. See drop inlet details.

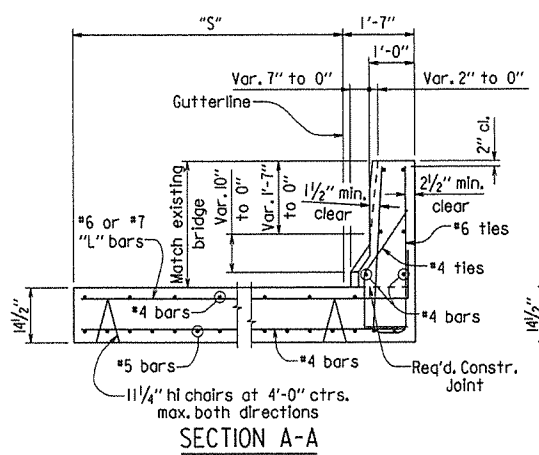

SECTION A-A
 $\frac{1}{2}'' = 1'-0''$

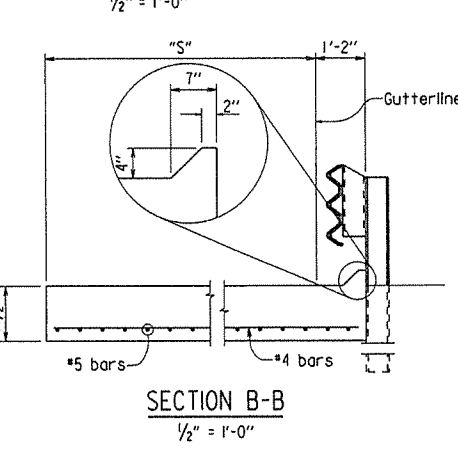

SECTION B-B
 $\frac{1}{2}'' = 1'-0''$

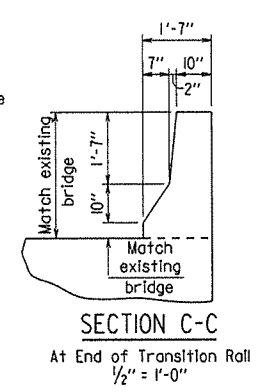

SECTION C-C
 At End of Transition Rail
 $\frac{1}{2}'' = 1'-0''$

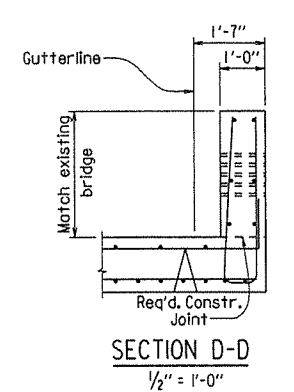

SECTION D-D
 $\frac{1}{2}'' = 1'-0''$

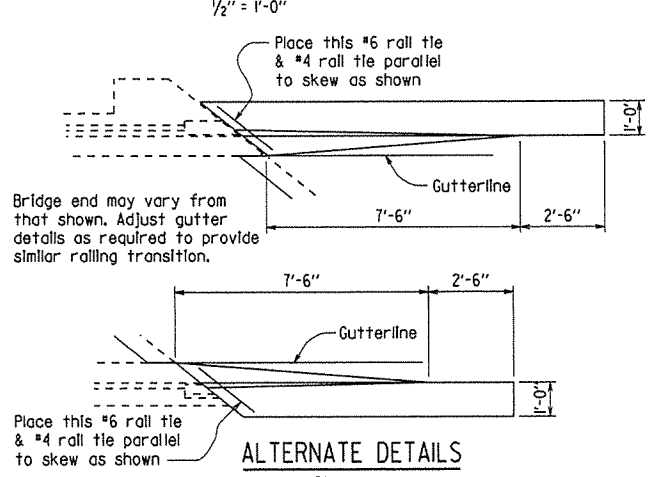

ALTERNATE DETAILS
 $\frac{3}{8}'' = 1'-0''$

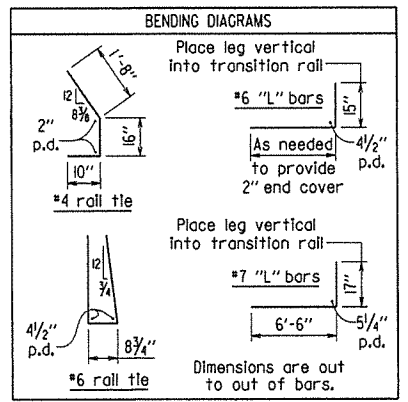

BENDING DIAGRAMS

DOWELING NOTE

If new approach slab is used, place dowels into approach slab using 18" embedment.
 If existing approach slab is retained, dowels shall be drilled and grouted 18" into existing slab. At the Contractor's option, existing dowels may be retained, cleaned and incorporated into new gutters. Work for drilling and grouting, or retaining and cleaning will not be paid for separately but will be considered subsidiary to "Approach Gutters".

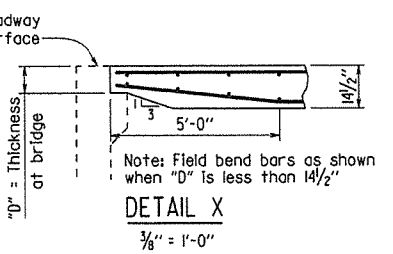

DETAIL X
 $\frac{3}{8}'' = 1'-0''$

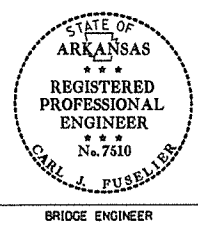

This document was originally issued and sealed by Carl J. Fuseller, PE No. 7510, on February 27, 2014. This copy is not a signed and sealed document.

GENERAL NOTES

All concrete shall be Class S or (SAE) or mixture used for Portland Cement Concrete Pavement and shall be poured in the dry.
 All reinforcing steel shall be Grade 60 (yield strength = 60,000 psi) conforming to AASHTO M 31 or M 322, Type A, with mill test reports. Fabricate bar lengths to provide 2" minimum cover at each end.
 Approach gutters will be measured and paid for in accordance with Section 504.

QUANTITIES FOR ONE SQUARE APPROACH GUTTER (FOR INFORMATION ONLY)

"S"	Concrete	Reinforcing Steel
5'-6"	12.49 cu.yd.	1227 lb.
5'-9"	12.91 cu.yd.	1276 lb.
6'-0"	13.34 cu.yd.	1296 lb.
9'-6"	19.23 cu.yd.	1746 lb.
9'-9"	19.65 cu.yd.	1795 lb.
10'-0"	20.07 cu.yd.	1815 lb.

STANDARD DETAILS FOR TYPE 'PT' APPROACH GUTTERS (BRIDGES WITH CONCRETE PARAPET RAILING)

ARKANSAS STATE HIGHWAY COMMISSION
 LITTLE ROCK, ARK.

DRAWN BY: KDH DATE: 2/27/2014 FILENAME: b55035.dgn
 CHECKED BY: KKY DATE: 2/27/2014 SCALE: AS SHOWN
 DESIGNED BY: STD. DATE:

DRAWING NO. 55035

REFER TO TABULATION OF QUANTITIES FOR 'W' & 'B' DIMENSIONS

REFER TO TABULATION OF QUANTITIES FOR 'W' DIMENSIONS

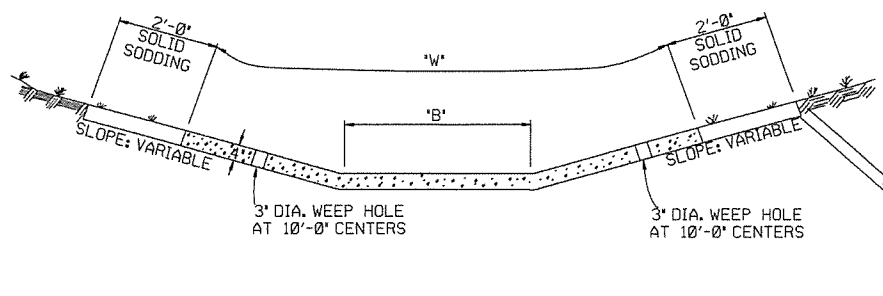

TYPE A

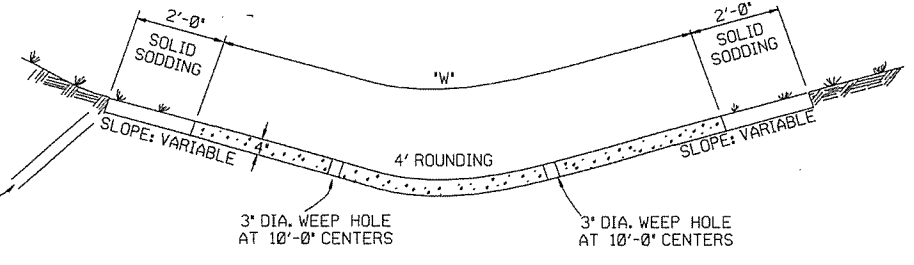

TYPE B

THE STEEL AND ADDITIONAL CONCRETE FOR THE WALLS SHALL NOT BE PAID FOR DIRECTLY, BUT SHALL BE CONSIDERED TO BE INCLUDED IN THE PRICE BID FOR 'CONCRETE DITCH PAVING.'

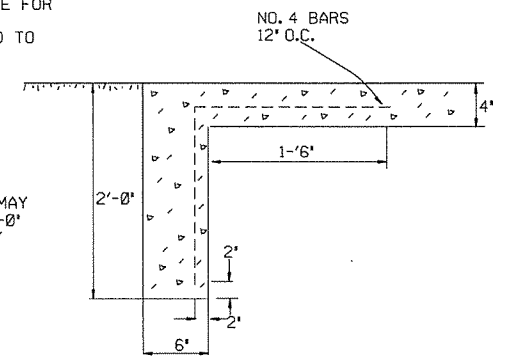

TOE WALL DETAIL FOR CONCRETE DITCH PAVING

GENERAL NOTES:

THE FULL WIDTH OF EACH SECTION SHALL BE POURED MONOLITHICALLY.

TOE WALLS TO BE CONSTRUCTED FULL WIDTH AT EACH END OF DITCH PAVING, AND POURED MONOLITHICALLY.

SOLID SOD ALONG DITCH PAVING TO BE PLACED WITHIN 14 DAYS OF DITCH PAVING CONSTRUCTION.

1" WIDE TRANSVERSE EXPANSION JOINTS SHALL BE PLACED IN CONCRETE DITCH PAVING AT 45' INTERVALS. THE SPACE SHALL BE FILLED WITH APPROVED JOINT FILLER COMPLYING WITH AASHTO M213.

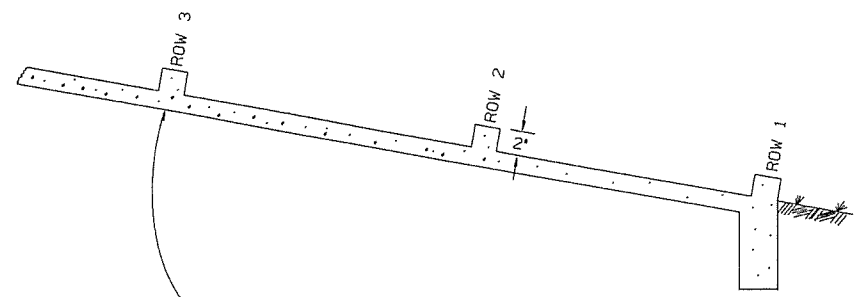

NUMBER OF ELEMENTS PER ROW VARIES WITH WIDTH OF PAVING SPECIFIED

ENERGY DISSIPATORS TO BE USED FOR THE ENTIRE LENGTH OF DITCH WHEN SLOPE OF DITCH PAVING EXCEEDS 7%. THE DISSIPATORS WILL NOT BE PAID FOR DIRECTLY, BUT SHALL BE CONSIDERED TO BE INCLUDED IN THE PRICE BID FOR CONCRETE DITCH PAVING.

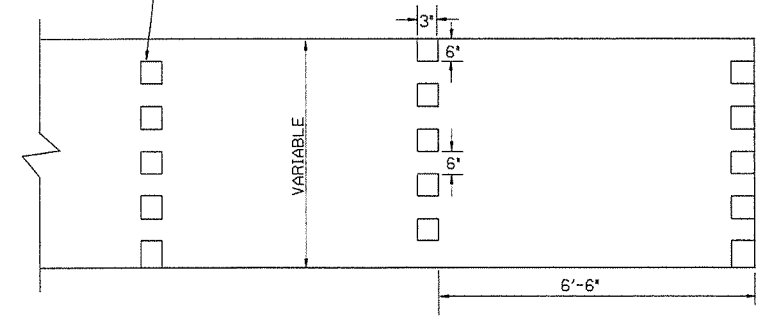

ENERGY DISSIPATORS
(NO SCALE)

DATE	REVISION	DATE FILM'D
11-17-10	ADDED GENERAL NOTE	
6-2-94	ADDED GENERAL NOTE ABOUT SOLID SODDING	
11-30-88	ELIMINATED MIN. ROWS OF ELEMENTS	111-30-89
7-15-88	REVISED DISSIPATOR NOTE	653-7-15-88
4-3-87	REVISED ENERGY DISSIPATOR	671-4-3-87
1-9-87	MODIFIED NOTE ON ENERGY DISS.	532-1-9-87
11-3-86	ADDED NOTE TO ENERGY DISS.	599-12-1-86
11-1-84	ENERGY DISSIPATOR DETAILS ADDED	508-11-1-84
11-1-84	EXCAVATION DETAILS ADDED	
10-2-72	TYPED A & B REVISED AND REDRAWN	508-10-2-72

ARKANSAS STATE HIGHWAY COMMISSION

CONCRETE DITCH PAVING

STANDARD DRAWING CDP-1

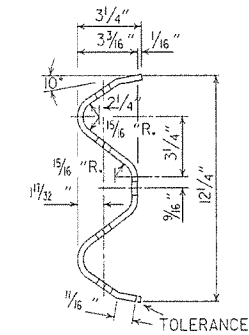
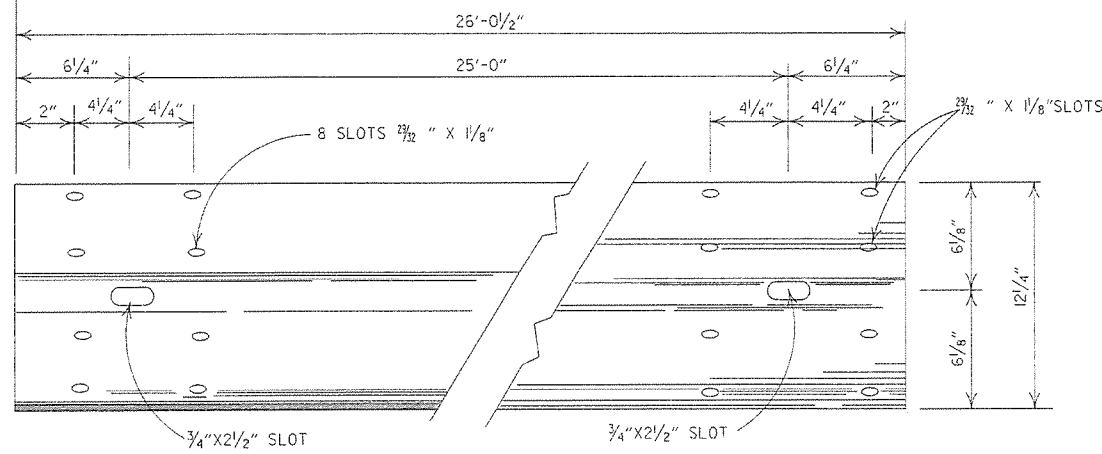

DETAILS OF W-BEAM GUARD RAIL

RAIL SECTION OF CLOSELY SIMILAR DIMENSIONS AND COMPARABLE STRENGTH MAY BE SUBSTITUTED IF APPROVED BY THE ENGINEER.

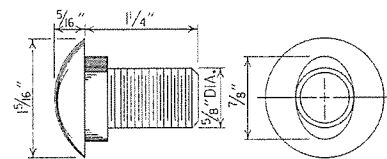

SPLICE BOLT
POST BOLT - SAME EXCEPT LENGTH

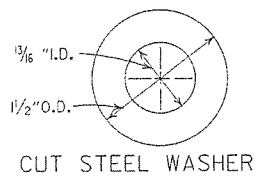

CUT STEEL WASHER

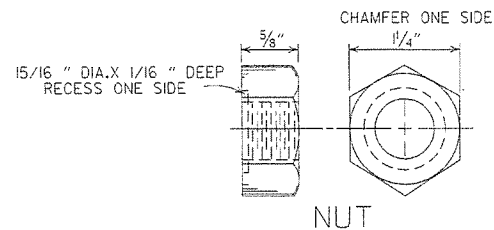

NUT

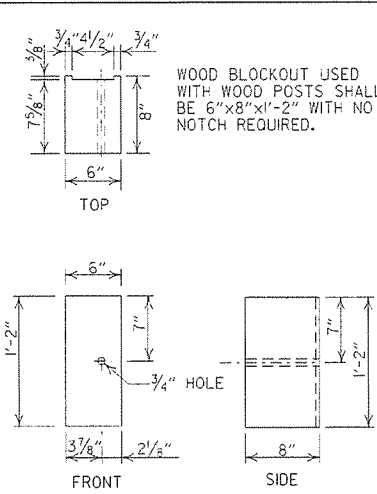

WOOD BLOCKOUT (W-BEAM)

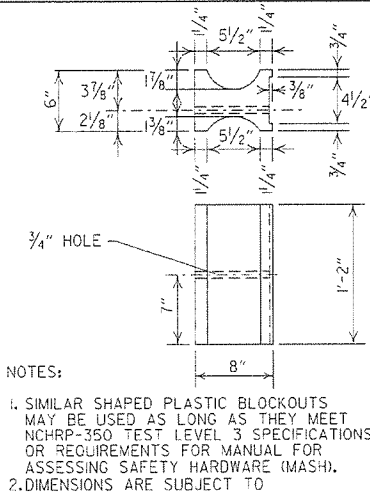

PLASTIC BLOCKOUT (W-BEAM)

NOTES:
1. SIMILAR SHAPED PLASTIC BLOCKOUTS MAY BE USED AS LONG AS THEY MEET NCHRP-350 TEST LEVEL 3 SPECIFICATIONS OR REQUIREMENTS FOR MANUAL FOR ASSESSING SAFETY HARDWARE (MASH).
2. DIMENSIONS ARE SUBJECT TO MANUFACTURERS TOLERANCES.

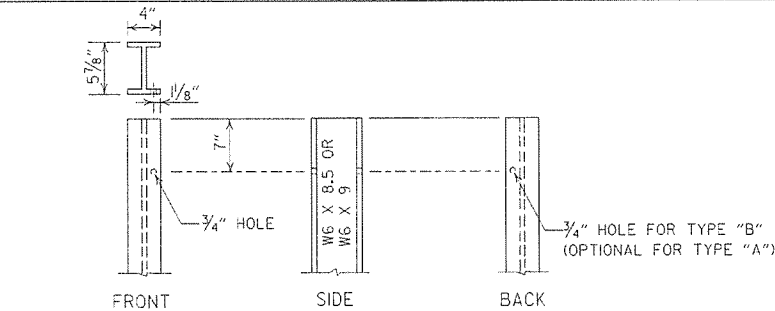

STEEL POST

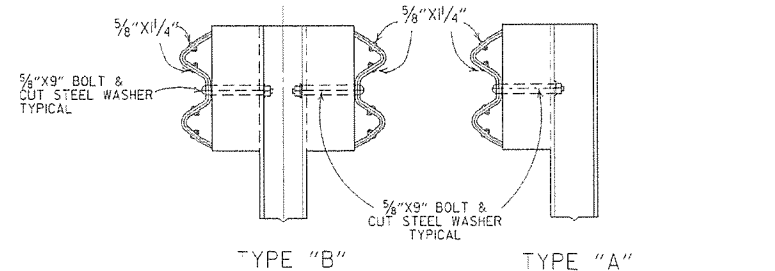

DETAILS OF STEEL LINE POST CONNECTIONS (W-BEAM)

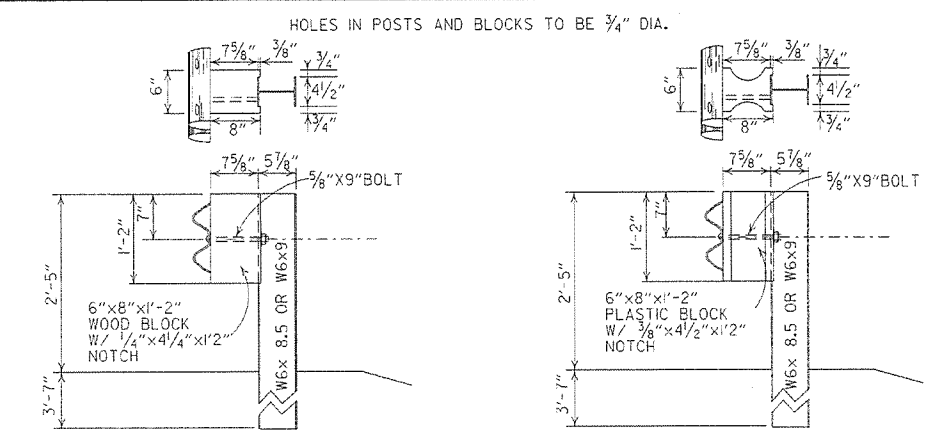

WOOD BLOCKOUT CONNECTIONS
PLASTIC BLOCKOUT CONNECTIONS
DETAILS OF STEEL LINE POST CONNECTIONS (W-BEAM)

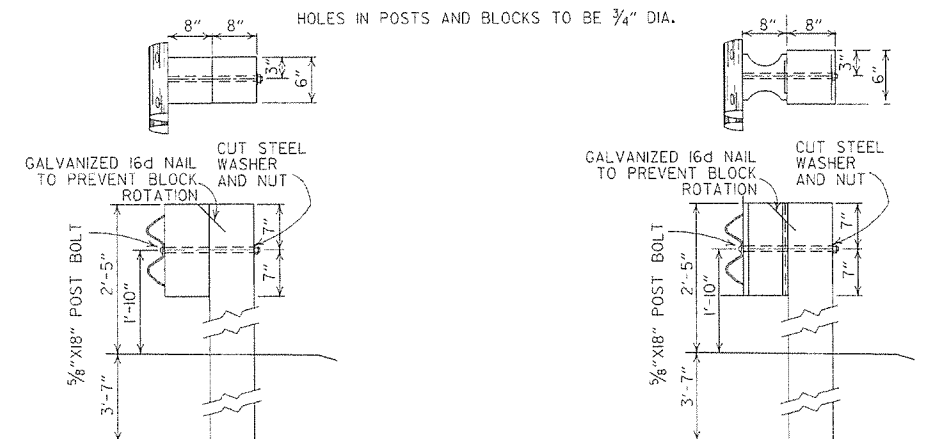

WOOD BLOCKOUT CONNECTIONS
PLASTIC BLOCKOUT CONNECTIONS
DETAILS OF WOOD LINE POST CONNECTIONS (W-BEAM)

-GENERAL NOTES-

ALL BOLTS SHALL BE SUFFICIENT LENGTH TO EXTEND THROUGH THE FULL THICKNESS OF THE NUT AND NO MORE THAN 3/4" BEYOND IT.
WHERE W-BEAM GUARD RAIL CONTINUES, THE INTERMEDIATE SECTIONS SHALL HAVE A POST SPACING OF 6'-3" UNLESS OTHERWISE NOTED.
W-BEAM GUARD RAIL REPRESENTING INTERMEDIATE SECTIONS WILL BE MEASURED ALONG THE ROADWAY FACE FROM CENTERLINE OF POST TO CENTERLINE OF POST.
USE W-BEAM GUARD RAIL COMPONENTS OF SAME MATERIAL FOR ENTIRE JOB. FOR EXTENSIONS OR MODIFICATION OF EXISTING GUARD RAIL, W-BEAM GUARD RAIL COMPONENTS OF THE SAME TYPE AS THOSE EXISTING SHALL BE USED.
ANY BACKFILLING UNDER OR AROUND POST SHALL BE DAMP SAND THOROUGHLY TAMPED IN PLACE.
WOOD POSTS & WOOD BLOCKS SHALL BE EITHER DENSE NO. 1 STRUCTURAL OR BETTER 9.7f (1400 f) OR NO. 1 1350 f SOUTHERN PINE.
CONTRACTOR SHALL HAVE THE OPTION OF USING WOOD BLOCKOUTS FOR W-BEAM GUARD RAIL OR PLASTIC BLOCKOUTS, AS LONG AS BLOCKOUT USED MEETS NCHRP-350 TEST LEVEL 3 SPECIFICATIONS OR REQUIREMENTS FOR MANUAL FOR ASSESSING SAFETY HARDWARE (MASH) FOR W-BEAM GUARD RAIL.

1-4-10	RAISED HEIGHT OF GUARD RAIL 1"	
0-15-09	ADDED REFERENCE TO MASH	
4-10-03	REVISED GENERAL NOTES	
8-22-02	REVISED DIMENSION ON WOOD & PLASTIC BLOCKOUT CONNECTIONS & ON STEEL POST	
11-16-01	REVISED WOOD BLOCKOUT & DETAILS OF WOOD LINE POST CONNECTIONS	
3-30-00	REMOVED GUARD RAIL AT BRIDGE ENDS	
1-12-00	ADDED PLASTIC BLOCKOUT	
8-12-98	REV. BLOCKOUTS TO WOOD, DELETED CONC. POST & REV. GENERAL NOTE, DELETED DET. OF GUARD RAIL REPLACE BEHIND CURB & DET. OF POST PLACE IN SOLID ROCK & ADDED DETAILS OF STEEL LINE POST CONN. REMOVED BACK-UP PLATE, REVISED HOLES IN STEEL POLES	
4-3-97	REMOVED "LAP IN DIRECTION OF TRAFFIC" NOTE & PLACED ARROWS ON WASHERS	
10-18-96	REVISED WOOD POST NOTE	
6-2-94	ADDED AT T. STEEL POST SIZE	
8-5-93	REVISED STEEL POST SIZE	8-5-93
10-1-92	REDRAWN & REVISED	10-1-92
8-15-91	REVISED WASHER NOTE	8-15-91
8-2-90	REV. GEN. NOTE & DEPTH OF ANC. POST IN ROCK	8-2-90
7-15-88	REVISED SECTION 3 & GENERAL NOTES	
3-4-88	REV. ANCHOR POST, ELEV. NOTES & POST IN ROCK	780-3-4-88
10-30-87	REVISED WOOD LINE POST DETAIL	546-10-30-87
10-9-87	REDRAWN & REVISED	802-10-9-87
DATE	REVISION	DATE FILM

ARKANSAS STATE HIGHWAY COMMISSION

GUARD RAIL DETAILS

STANDARD DRAWING GR-8

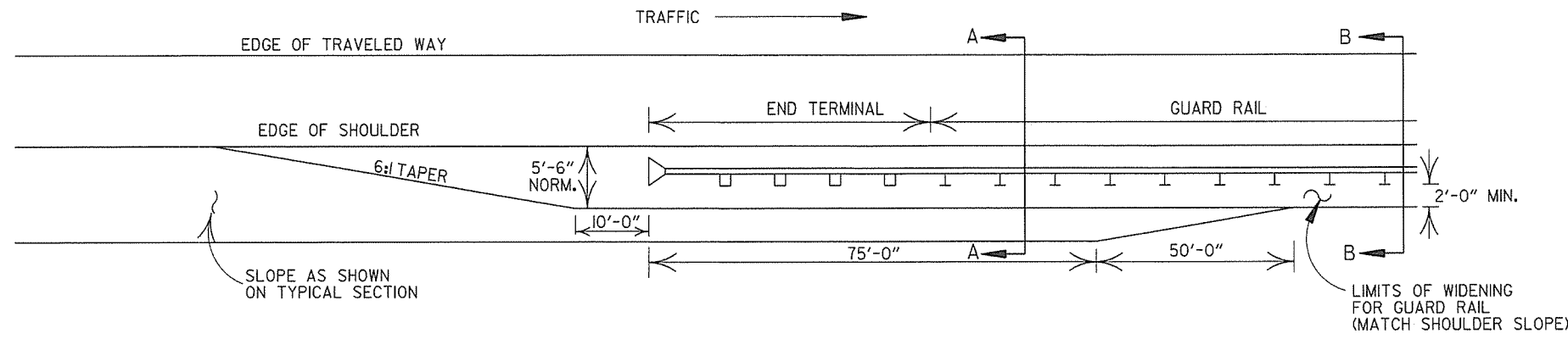

NOTE: NORMAL SECTION TO BE WIDENED APPROX. 5'-6" EACH SIDE TO SUPPORT GUARD RAIL.

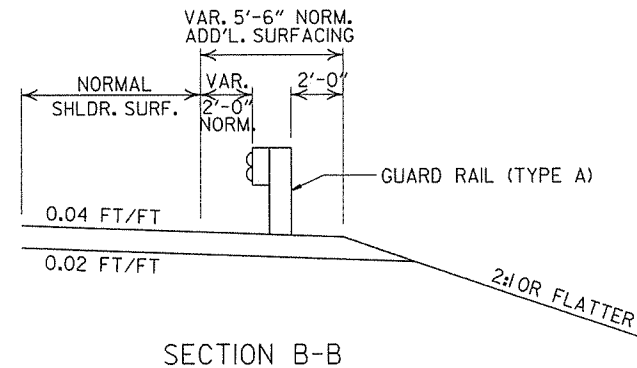
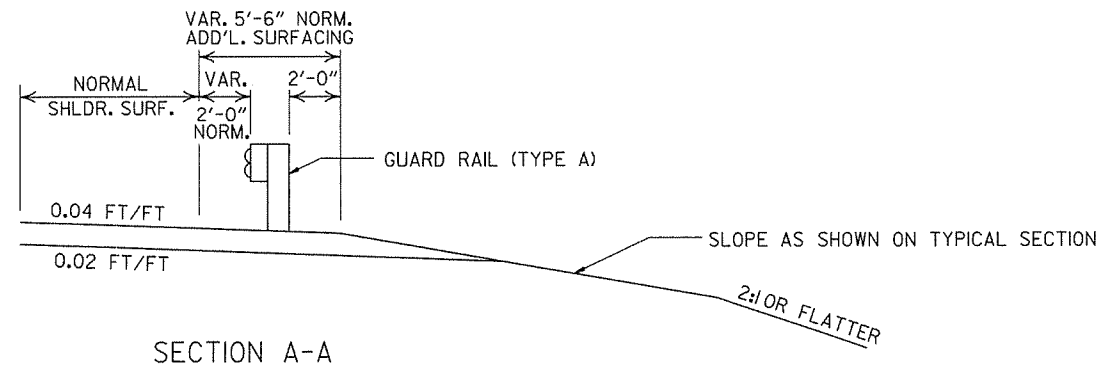

DETAILS OF WIDENING FOR GUARD RAIL

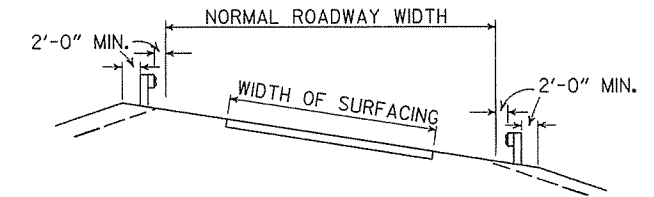
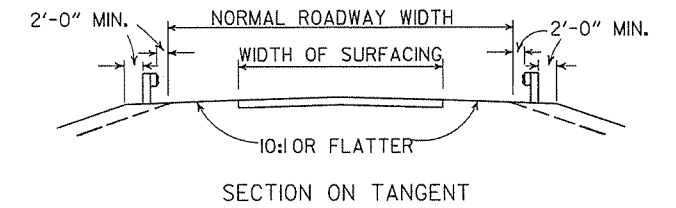

DETAILS SHOWING POSITION OF GUARD RAIL ON HIGHWAY

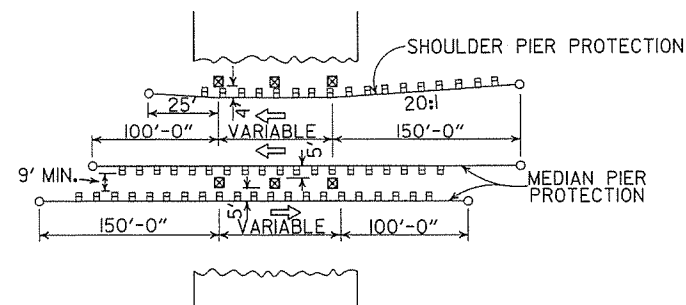

METHOD OF INSTALLATION OF GUARD RAIL AT FIXED OBSTACLE

				ARKANSAS STATE HIGHWAY COMMISSION	
				GUARD RAIL DETAILS	
				STANDARD DRAWING GR-9A	
4-17-08	MINOR REVISION				
11-10-05	DRAWN				
DATE	REVISION			DATE	FILM

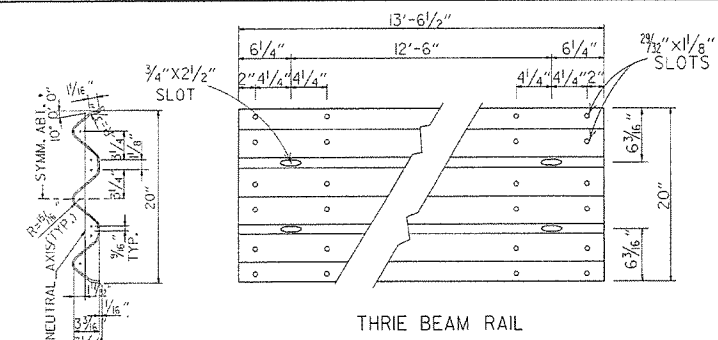

SECTION THRU THRIE BEAM RAIL

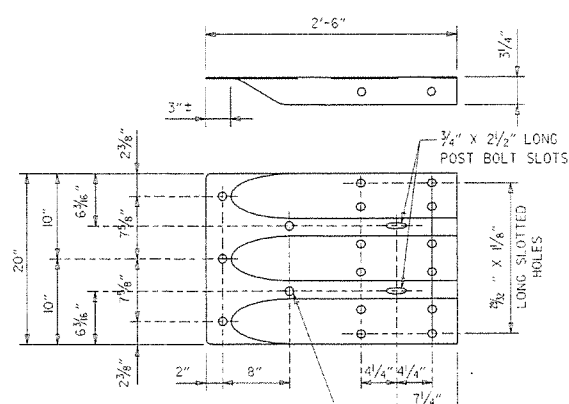

SPECIAL END SHOE

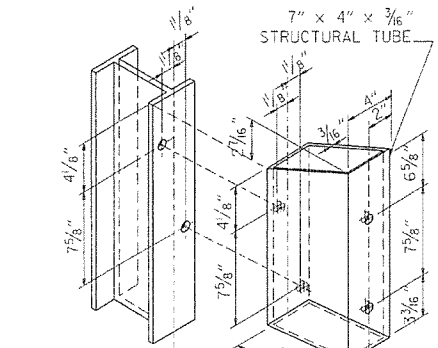

STRUCTURAL STEEL TUBING BLOCKOUT DETAIL

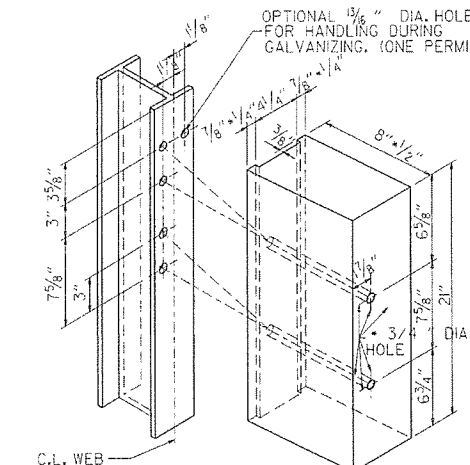

HOLE PUNCHING DETAIL FOR STEEL POST & WOOD OR PLASTIC BLOCKOUTS

ATTACH BLOCKOUT TO POST USING 5/8\"/>

1\"/>

NOTE: SEE STANDARD DRAWING GR-10A FOR GUARD RAIL POST EMBEDMENT DEPTHS.

CONNECTOR PLATE

CONNECTOR PLATE SHALL BE AASHTO M270, GR. 36 AND SHALL BE GALVANIZED AFTER FABRICATION. GALVANIZING SHALL CONFORM TO SUBSECTION 807.19 OF THE STANDARD SPECIFICATIONS. CONNECTOR PLATE TO BE BOLTED TO SPECIAL END SHOE USING 1/2\"/>

NOTE: BLOCKS SHALL BE THE SAME TYPE THROUGHOUT THE PROJECT LIMITS.

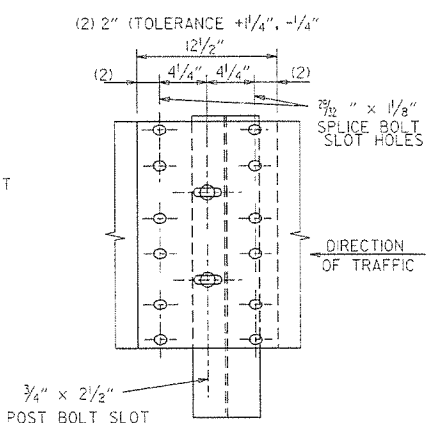

THRIE BEAM RAIL SPLICE AT POST

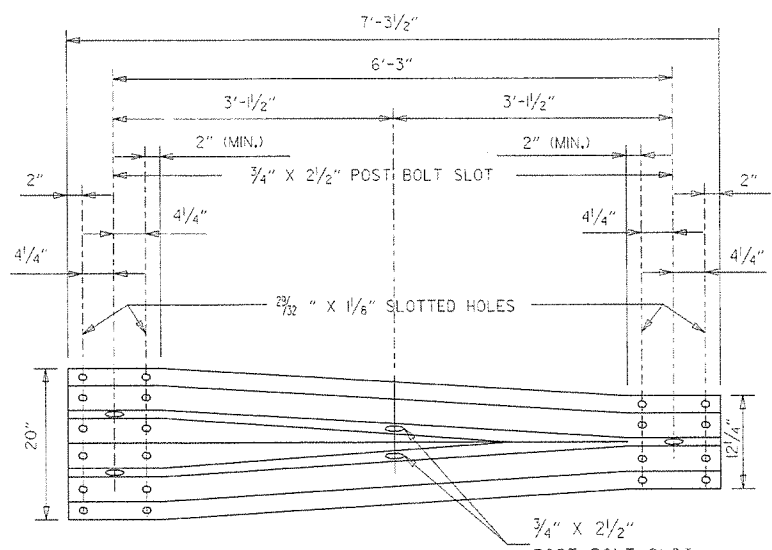

TRANSITION SECTION

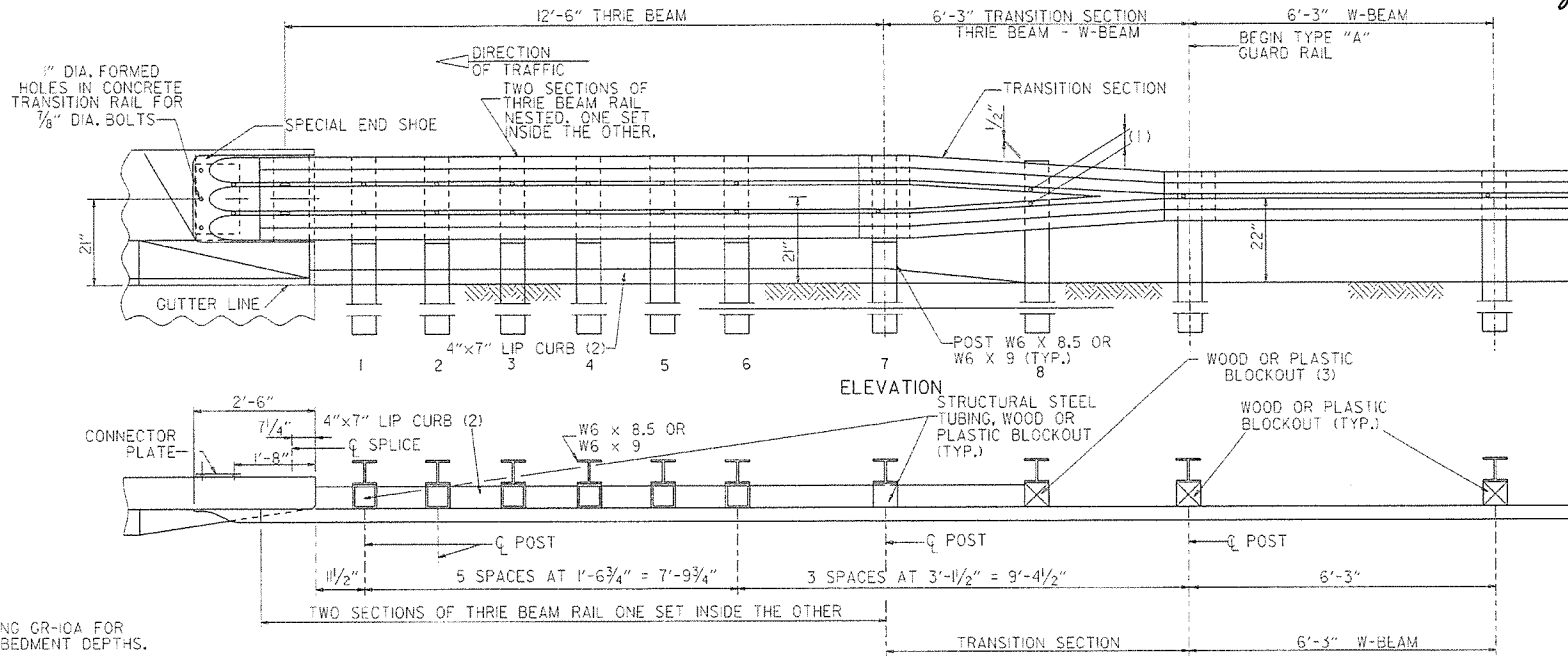

ELEVATION

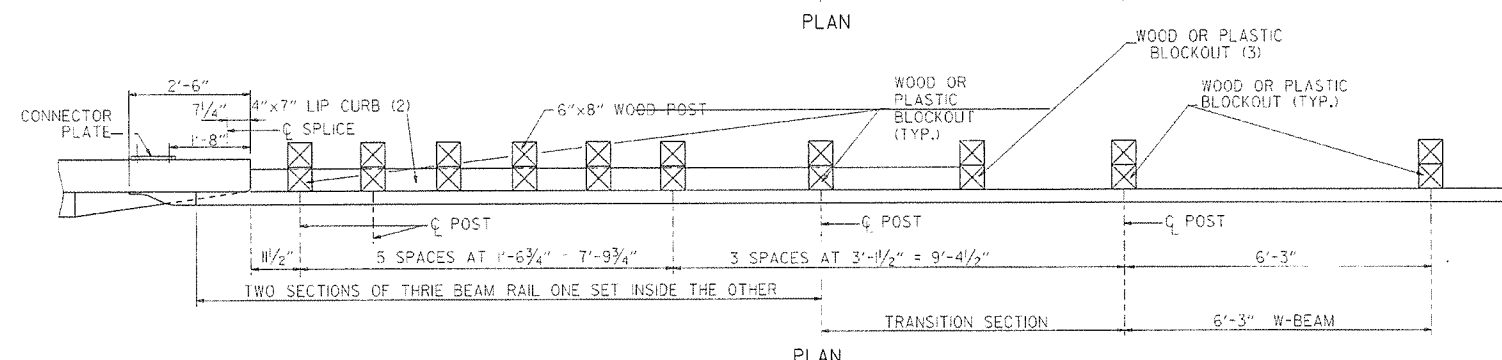

PLAN

PLAN

- (1) VERIFY BOLT SPACING FROM RAIL TRANSITION PRODUCER.
- (2) REFER TO APPROACH GUTTER DETAILS.
- (3) LENGTH OF BLOCKOUT ON POST B TO BE MODIFIED TO FIT RAIL WIDTH.

THRIE BEAM GUARD RAIL CONNECTION AT BRIDGE ENDS

GENERAL NOTES:

THE THRIE BEAM RAIL, SPECIAL END SHOE, AND THE TRANSITION SECTION SHALL BE MADE OF STEEL AND SHALL BE 12 GAGE. ZINC COATING SHALL BE TYPE 1.
 RAIL POSTS SHALL BE SET PERPENDICULAR TO THE ROADWAY PROFILE GRADE AND VERTICALLY IN CROSS SECTION.
 ALL BOLTS SHALL BE SUFFICIENT LENGTH TO EXTEND THROUGH THE FULL THICKNESS OF THE NUT AND NO MORE THAN 3/4\"/>

DATE	REVISION	DATE FILM
7-14-10	RAISED HEIGHT OF W-BEAM 1"	
11-29-07	ADDED PLASTIC BLOCKOUTS	
11-10-05	ADDED NOTE FOR ATTACHING STEEL BLOCKOUT	
11-18-04	REVISED GENERAL NOTES	
10-9-03	REVISED GENERAL NOTES	
4-10-03	REVISED GENERAL NOTES	
8-22-02	REVISED NOTE (2)	
6-29-00	MOVED DIMENSION LINES	
5-18-00	ADDED NOTE	
3-30-00	DRAWN & ISSUED	

ARKANSAS STATE HIGHWAY COMMISSION		
GUARD RAIL DETAILS		
STANDARD DRAWING GR-10		

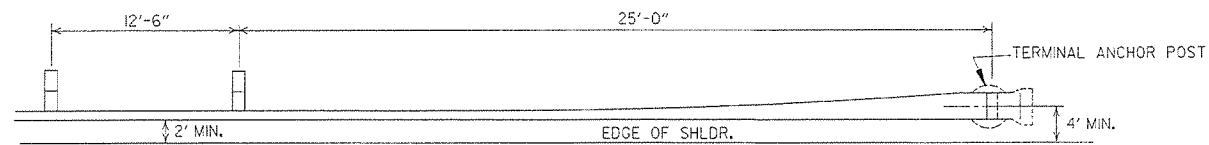

PLAN - GUARD RAIL TERMINAL (TYPE I)

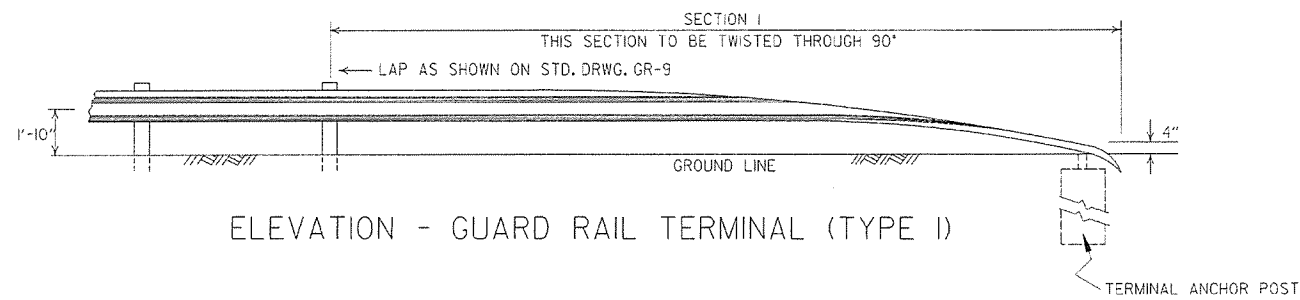

ELEVATION - GUARD RAIL TERMINAL (TYPE I)

NOTE:
SECTIONS 1 AND 2 OF GUARD RAIL TERMINAL
SHALL BE PAID FOR AT THE PRICE BID PER
LINEAR FOOT OF THE TYPE OF GUARD RAIL SPECIFIED.

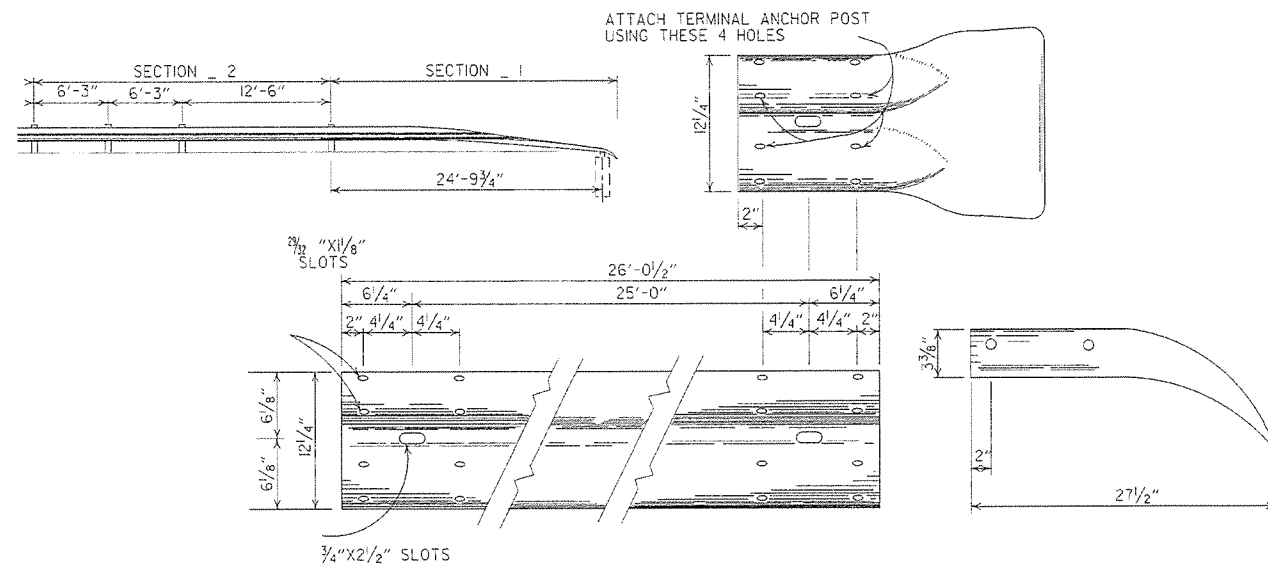

SECTION 1

TERMINAL SECTION

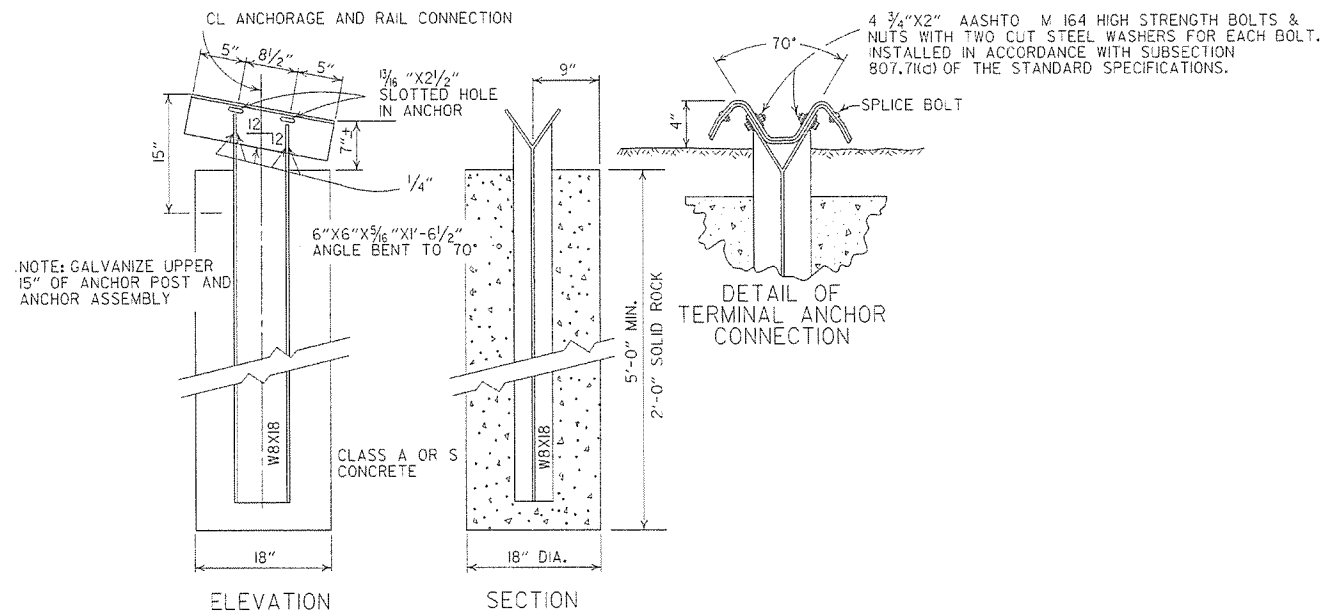

DETAIL OF TERMINAL ANCHOR POST (TYPE I)

NOTE: GALVANIZE UPPER 15" OF ANCHOR POST AND ANCHOR ASSEMBLY
NOTE: RAIL MEMBERS MAY BE BOLTED TO ANGLE AT TERMINAL ANCHOR AND THE TWO ASSEMBLIES POSITIONED TO PROPER ALIGNMENT PRIOR TO PLACING CONCRETE AROUND 8 WF 17 POST IF CONTRACTOR SO DESIRES.

			ARKANSAS STATE HIGHWAY COMMISSION
			GUARD RAIL DETAILS
7-14-10	RAISED HEIGHT OF GUARD RAIL 1"		STANDARD DRAWING GRT-1
6-26-97	REVISED LAP NOTE		
10-18-96	REVISED ASTM REF. TO AASHTO		
11-3-94	DIMENSION TERMINAL DETAIL		
11-11-92	ADDED NOTE FOR PAYMENT	11-11-92	
10-1-92	DRAWN & ISSUED	10-1-92	
DATE	REVISION	DATE FILED	

REINFORCED CONCRETE ARCH PIPE DIMENSIONS

EQUIV. DIA.	SPAN		RISE	
	AASHTO M 206	AHTD NOMINAL	AASHTO M 206	AHTD NOMINAL
INCHES	INCHES			
15	18	18	11	11
18	22	22	13½	14
21	26	26	15½	16
24	28½	29	18	18
30	36¼	36	22½	23
36	43¾	44	26¾	27
42	51½	51	31½	31
48	58½	59	36	36
54	65	65	40	40
60	73	73	45	45
72	88	88	54	54
84	102	102	62	62
90	115	115	72	72
96	122	122	77½	77
108	138	138	87½	87
120	154	154	96¾	97
132	168¼	169	106½	107

THE MEASURED SPAN AND RISE SHALL NOT VARY MORE THAN ± 2 PERCENT FROM THE VALUES SPECIFIED BY AASHTO M206.

REINFORCED CONCRETE HORIZONTAL ELLIPTICAL PIPE DIMENSIONS

EQUIV. DIA.	AASHTO M 207	
	SPAN	RISE
INCHES	INCHES	
18	23	14
24	30	19
27	34	22
30	38	24
33	42	27
36	45	29
39	49	32
42	53	34
48	60	38
54	68	43
60	76	48
66	83	53
72	91	58
78	98	63
84	106	68

THE MEASURED SPAN AND RISE SHALL NOT VARY MORE THAN ± 2 PERCENT FROM THE VALUES SPECIFIED BY AASHTO M207.

CONSTRUCTION SEQUENCE

1. PLACE STRUCTURAL BEDDING MATERIAL TO GRADE. DO NOT COMPACT.
2. INSTALL PIPE TO GRADE.
3. COMPACT STRUCTURAL BEDDING OUTSIDE THE MIDDLE THIRD OF THE PIPE.
4. PLACE AND COMPACT THE HAUNCH AREA UP TO THE MIDDLE OF THE PIPE.
5. COMPLETE BACKFILL ACCORDING TO SUBSECTION 606.03.(f)(ii).

NOTE: HAUNCH AND STRUCTURAL BEDDING MATERIAL WILL NOT BE PAID FOR SEPARATELY, BUT COMPENSATION WILL BE CONSIDERED TO BE INCLUDED IN THE PRICE BID PER LINEAR FOOT OF CONCRETE PIPE.

- LEGEND -

- D_i = NORMAL INSIDE DIAMETER OF PIPE
- D_o = OUTSIDE DIAMETER OF PIPE
- H = FILL COVER HEIGHT OVER PIPE (FEET)
- MIN. = MINIMUM
- UNDISTURBED SOIL

INSTALLATION TYPE	MATERIAL REQUIREMENTS FOR HAUNCH AND STRUCTURAL BEDDING
TYPE 1	AGGREGATE BASE COURSE (CLASS 5 OR CLASS 7)
TYPE 2	SELECTED MATERIALS (CLASS SM-1, SM-2, OR SM-4) OR TYPE 1 INSTALLATION MATERIAL*
TYPE 3**	AASHTO CLASSIFICATION A-1 THRU A-6 SOIL OR TYPE 1 OR 2 INSTALLATION MATERIAL

*SM-3 WILL NOT BE ALLOWED.
** MATERIALS SHALL NOT INCLUDE ORGANIC MATERIALS OR STONES LARGER THAN 3 INCHES.

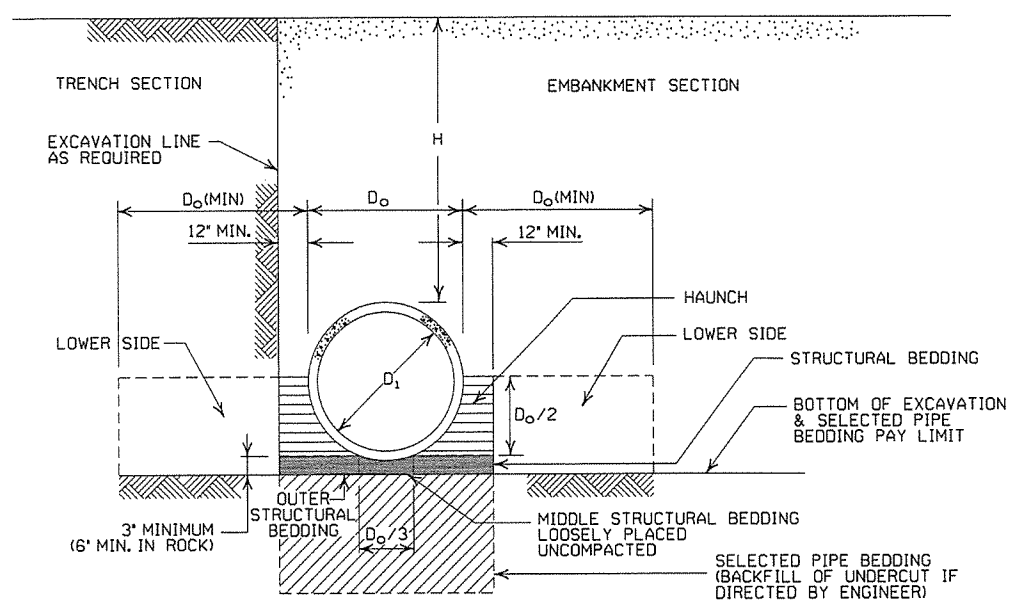

EMBANKMENT AND TRENCH INSTALLATIONS

1. MATERIAL IN THE HAUNCH AND OUTER STRUCTURAL BEDDING SHALL BE COMPACTED TO 95% OF THE MAXIMUM DENSITY ACCORDING TO THE TYPE OR CLASS OF MATERIAL USED.
2. FOR TRENCHES WITH WALLS OF NATURAL SOIL, THE DENSITY OF THE SOIL IN THE LOWER SIDE ZONE SHALL BE AS FIRM AS THE 95% DENSITY REQUIRED FOR THE HAUNCH. IF THE EXISTING SOIL DOES NOT MEET THIS CRITERIA, IT SHALL BE REMOVED AND RECOMPACTED TO 95% OF THE MAXIMUM DENSITY ACCORDING TO THE TYPE OF MATERIAL USED.
3. FOR EMBANKMENTS, THE MATERIAL IN THE LOWER SIDE ZONE SHALL BE COMPACTED TO 95% OF THE MAXIMUM DENSITY ACCORDING TO THE TYPE OR CLASS OF MATERIAL USED.

GENERAL NOTES

1. CONCRETE PIPE CULVERT CONSTRUCTION SHALL CONFORM TO ARKANSAS STATE HIGHWAY AND TRANSPORTATION DEPARTMENT STANDARD SPECIFICATIONS FOR HIGHWAY CONSTRUCTION (CURRENT EDITION), WITH APPLICABLE SUPPLEMENTAL SPECIFICATIONS AND SPECIAL PROVISIONS, UNLESS OTHERWISE NOTED IN THE PLANS, SECTION AND SUBSECTION REFER TO THE STANDARD CONSTRUCTION SPECIFICATIONS.
2. CONCRETE PIPE CULVERT DESIGN SHALL CONFORM TO AASHTO LRFD BRIDGE DESIGN SPECIFICATIONS, FIFTH EDITION (2010) WITH 2010 INTERIMS.
3. ALL PIPE SHALL CONFORM TO SECTION 606. CIRCULAR R.C. PIPE CULVERTS SHALL CONFORM TO AASHTO M170. R.C. ARCH PIPE CULVERTS SHALL CONFORM TO AASHTO M206 AND HORIZONTAL ELLIPTICAL PIPE CULVERTS SHALL CONFORM TO AASHTO M207.
4. ALL PIPE SHALL BE PROTECTED DURING CONSTRUCTION BY A COVER SUFFICIENT TO PREVENT DAMAGE FROM PASSAGE OF EQUIPMENT.
5. THE MINIMUM TRENCH WIDTH SHALL BE THE OUTSIDE DIAMETER OF THE PIPE PLUS 24 INCHES. THE MAXIMUM ALLOWABLE TRENCH WIDTH SHALL BE THE MINIMUM WIDTH PRACTICABLE FOR WORKING CONDITIONS.
6. MULTIPLE PIPE CULVERTS SHALL BE INSTALLED WITH A MINIMUM CLEARANCE OF 24 INCHES BETWEEN STRINGS OF PIPE. REFER TO STD. DWG. FES-2 FOR MINIMUM CLEARANCE WHERE FLARED END SECTIONS ARE USED.
7. IMPERVIOUS MATERIAL SHOULD BE PLACED AS DIRECTED BY THE ENGINEER AT THE ENDS OF THE CULVERT TO PREVENT LOSS OF STRUCTURAL BEDDING WHEN PERVIOUS MATERIAL IS USED FOR STRUCTURAL BEDDING AND/OR BACKFILL.
8. NOT MORE THAN ONE LIFTING HOLE MAY BE PROVIDED IN CONCRETE PIPE TO FACILITATE HANDLING. HOLE MAY BE CAST IN PLACE, CUT INTO THE FRESH CONCRETE AFTER FORMS ARE REMOVED, OR DRILLED. THE HOLE SHALL NOT BE MORE THAN TWO INCHES IN DIAMETER OR TWO INCHES SQUARE. CUTTING OR DISPLACEMENT OF REINFORCEMENT WILL NOT BE PERMITTED. SPALLED AREAS AROUND THE HOLE SHALL BE REPAIRED IN A WORKMANLIKE MANNER. LIFTING HOLE SHALL BE FILLED WITH MORTAR, CONCRETE, OR OTHER METHOD AS APPROVED BY THE ENGINEER.
9. WHEN DIRECTED BY THE ENGINEER, UNSUITABLE MATERIAL THAT IS ENCOUNTERED AT THE BOTTOM OF THE EXCAVATED TRENCH (BELOW THE AREA IDENTIFIED AS "STRUCTURAL BEDDING" ABOVE) WILL BE EXCAVATED AND REPLACED WITH SELECTED PIPE BEDDING. THE QUANTITY OF MATERIAL REQUIRED TO BACKFILL THE UNDERCUT AREA UP TO THE SELECTED PIPE BEDDING PAY LIMIT DESIGNATED ABOVE WILL BE MEASURED AND PAID FOR AS "SELECTED PIPE BEDDING."
10. WHEN THE EXISTING MATERIAL EXCAVATED FOR THE PIPE TRENCH IS DETERMINED BY THE ENGINEER TO BE UNSUITABLE FOR BACKFILLING THE PIPE (ABOVE THE AREA IDENTIFIED ABOVE AS THE HAUNCH), BORROW MATERIAL OR MATERIAL FROM THE ROADWAY EXCAVATION WILL BE USED TO BACKFILL THE PIPE. IF SUITABLE MATERIAL IS NOT AVAILABLE, THE ENGINEER MAY AUTHORIZE THE USE OF "SELECTED PIPE BACKFILL."

MINIMUM HEIGHT OF FILL "H" OVER CIRCULAR R.C. PIPE CULVERTS

INSTALLATION TYPE	CLASS OF PIPE			
	CLASS III		CLASS IV	CLASS V
PIPE ID (IN.)	TYPE 1 OR 2	TYPE 3	ALL	ALL
	FEET			
12-15	2	2.5	2	1
18-24	2.5	3	2	1
27-33	3	4	2	1
36-42	3.5	5	2	1
48	4.5	5.5	2	1
54-60	5	7	2	1
66-78	6	8	2	1
84-108	7.5	8	2	1

NOTE: FOR MINIMUM COVER VALUES, "H" SHALL INCLUDE A MINIMUM OF 12" OF PAVEMENT AND/OR BASE.

MAXIMUM HEIGHT OF FILL "H" OVER CIRCULAR R.C. PIPE CULVERTS

INSTALLATION TYPE	CLASS OF PIPE		
	CLASS III	CLASS IV	CLASS V
	FEET		
TYPE 1	21	32	50
TYPE 2	16	25	39
TYPE 3	12	20	30

NOTE: IF FILL HEIGHT EXCEEDS 50 FEET, A SPECIAL DESIGN CONCRETE PIPE WILL BE REQUIRED USING TYPE 1 INSTALLATION.

MINIMUM HEIGHT OF FILL "H" OVER R.C. ARCH & HORIZONTAL ELLIPTICAL PIPE CULVERTS

INSTALLATION TYPE	CLASS OF PIPE	
	CLASS III	CLASS IV
	FEET	
TYPE 2 OR TYPE 3	2.5	1.5

NOTE: TYPE 1 INSTALLATION WILL NOT BE ALLOWED FOR ARCH & HORIZONTAL ELLIPTICAL PIPE CULVERTS.

NOTE: FOR MINIMUM COVER VALUES, "H" SHALL INCLUDE A MINIMUM OF 12" OF PAVEMENT AND/OR BASE.

MAXIMUM HEIGHT OF FILL "H" OVER R.C. ARCH & HORIZONTAL ELLIPTICAL PIPE CULVERTS

INSTALLATION TYPE	CLASS OF PIPE	
	CLASS III	CLASS IV
	FEET	
TYPE 2	13	21
TYPE 3	10	16











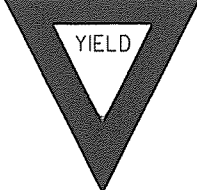
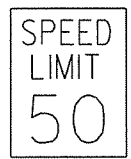



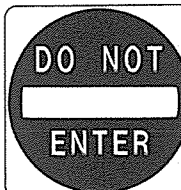
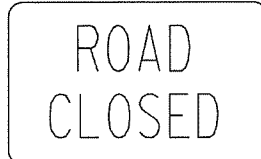
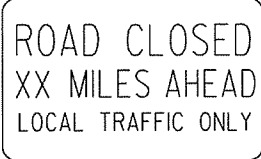
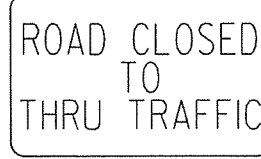
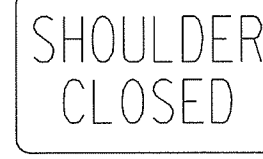
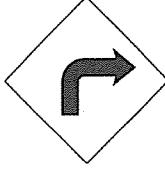

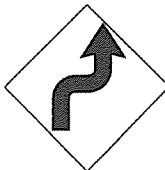

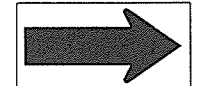
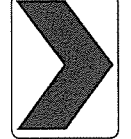
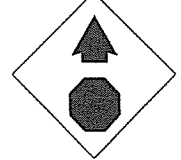
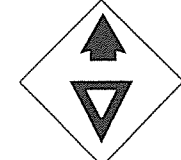
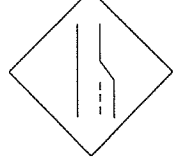

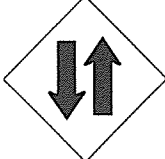

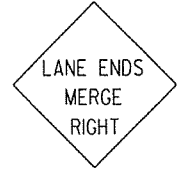
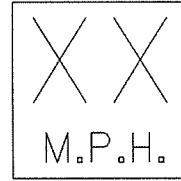

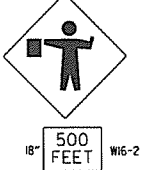

NOTE: TYPE 1 INSTALLATION WILL NOT BE ALLOWED FOR ARCH & HORIZONTAL ELLIPTICAL PIPE CULVERTS.

DATE	REVISION	DATE FILMED
2-27-14	REVISED GENERAL NOTE 1.	
12-15-11	REVISED FOR LRFD DESIGN SPECIFICATIONS	
5-18-00	REVISED TYPE 3 BEDDING & ADDED NOTE	
3-30-00	REVISED INSTALLATIONS	
11-06-97	ISSUED	

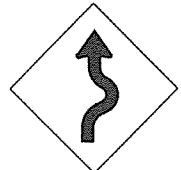
ARKANSAS STATE HIGHWAY COMMISSION

CONCRETE PIPE CULVERT
FILL HEIGHTS & BEDDING

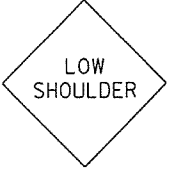
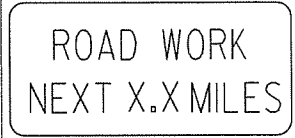
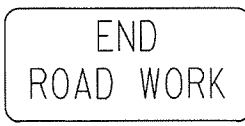
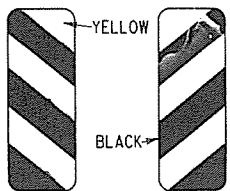
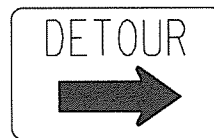
STANDARD DRAWING PCC-1

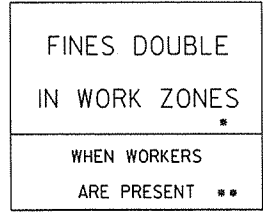
<p>RI-1</p>  <p>STANDARD 30"x30" EXPRESSWAY 36"x36" SPECIAL 48"x48"</p>	<p>RI-2</p>  <p>STD. 36"x36"x36" EXPWY. 48"x48"x48" FWY. 60"x60"x60"</p>	<p>R2-1</p>  <p>STD. 24"x30" EXPWY. 36"x48" FWY. 48"x60"</p>	<p>R2-5A</p>  <p>STD. 24"x30" EXPWY. 36"x48" FWY. 48"x60"</p>	<p>R2-5C</p>  <p>STD. 24"x30" EXPWY. 36"x48" FWY. 48"x60"</p>	<p>R4-1</p>  <p>STD. 24"x30" EXPWY. 36"x48" FWY. 48"x60"</p>	<p>R4-2</p>  <p>STD. 24"x30" EXPWY. 36"x48" FWY. 48"x60"</p>	
<p>R5-1</p>  <p>STD. 30"x30" EXPWY. 36"x36" SPECIAL 48"x48"</p>	<p>R11-2</p>  <p>48"x30"</p>	<p>R11-3A</p>  <p>60"x30"</p>	<p>R11-4</p>  <p>60"x30"</p>	<p>RSP-1</p>  <p>48"x30"</p>	<p>WI-1</p>  <p>STD. 36"x36" FWY. 48"x48"</p>	<p>WI-2</p>  <p>STD. 36"x36" FWY. 48"x48"</p>	
<p>WI-3</p>  <p>STD. 48"x48"</p>	<p>WI-4</p>  <p>STD. 48"x48"</p>	<p>WI-6</p>  <p>STD. 48"x24" SPECIAL 60"x30"</p>	<p>WI-8</p>  <p>STD. 18"x24" SPECIAL 24"x30" EXPWY. 30"x36" FWY. 36"x48"</p>	<p>W3-1</p>  <p>STD. 36"x36" SPECIAL 48"x48"</p>	<p>W3-2</p>  <p>STD. 36"x36" SPECIAL 48"x48"</p>	<p>W4-2</p>  <p>STD. 36"x36" FWY. 48"x48"</p>	
<p>W5-1</p>  <p>STD. 36"x36" SPECIAL 48"x48"</p>	<p>W6-3</p>  <p>EXPWY. 36"x36" SPECIAL 48"x48"</p>	<p>W8-7</p>  <p>EXPWY. 36"x36" FWY. 48"x48"</p>	<p>W9-2</p>  <p>STD. 36"x36" FWY. 48"x48"</p>	<p>W13-1</p>  <p>STD. 24"x24"</p>	<p>W20-1</p>  <p>STD. 48"x48"</p>	<p>W20-2</p>  <p>STD. 48"x48"</p>	<p>W20-3</p>  <p>STD. 48"x48"</p>
<p>W20-4</p>  <p>STD. 48"x48"</p>	<p>W20-5</p>  <p>STD. 48"x48"</p>	<p>W20-7a</p>  <p>STD. 36"x36" FWY. 48"x48"</p>	<p>W21-2</p>  <p>STD. 30"x30" SPECIAL 36"x36"</p>	<p>W21-5</p>  <p>STD. 30"x30" SPECIAL 36"x36"</p>	<p>W24-1</p>  <p>STD. 36"x36"</p>	<p>WI-4b</p>  <p>STD. 48"x48"</p>	<p>R56-1</p>  <p>STD. 18"x18"</p>
<p>W8-11</p>  <p>STD. 36"x36" FWY. 48"x48"</p>	<p>W8-9</p>  <p>STD. 36"x36" FWY. 48"x48"</p>	<p>G20-1</p>  <p>60"x24"</p>	<p>G20-2</p>  <p>48"x24"</p>	<p>OM-3L OM-3R</p>  <p>12"x36"</p>	<p>M4-9</p>  <p>STD. 30"x24" SPECIAL 48"x36" SPECIAL 60"x48"</p>	<p>M4-10</p>  <p>48"x18"</p>	<p>R55-1</p>  <p>36"x60" * USE 6" C LETTERS</p>

ADVANCE DISTANCES (XXXX)

500 FT	1/2 MILE
1000 FT	3/4 MILE
1500 FT	1 MILE AHEAD

GENERAL NOTES:

- ALL TRAFFIC CONTROL DEVICES USED ON ROAD CONSTRUCTION SHALL CONFORM TO THE MANUAL ON UNIFORM TRAFFIC CONTROL DEVICES, LATEST EDITION, AND TO THE STANDARD HIGHWAY SIGNS, LATEST EDITION, OR AS APPROVED BY THE FEDERAL HIGHWAY ADMINISTRATION.
- TRAFFIC CONTROL DEVICES SHALL BE SET UP JUST BEFORE THE START OF CONSTRUCTION OPERATIONS AND SHALL BE PROPERLY MAINTAINED DURING THE TIME SUCH CONDITIONS EXIST. THEY SHALL REMAIN IN PLACE ONLY AS LONG AS NEEDED AND REMOVED THEREAFTER.
- EXISTING SIGNS AND CONSTRUCTION SIGNS SHALL BE KEPT IN PROPER POSITION, AND BE CLEAN AND LEGIBLE AT ALL TIMES. SIGNS THAT DO NOT APPLY TO EXISTING CONDITIONS SHALL BE REMOVED. SIGNS THAT ARE DAMAGED, DEFACED, OR THAT ACCUMULATE DIRT DURING CONSTRUCTION SHALL BE CLEANED, REPAIRED, OR REPLACED.
- SIGNS ARE USUALLY MOUNTED ON A SINGLE POST, ALTHOUGH THOSE WIDER THAN 36" OR LARGER THAN 10 SQ. FT. SHALL BE MOUNTED ON TWO POSTS OR ABOVE A TYPE III BARRICADE.
- SIGN POSTS DIRECT BURIED IN SOIL SHALL BE 2 LB. MINIMUM CHANNEL POST OR 4"x4" WOOD POSTS. CHANNEL POSTS SHALL BE PAINTED GREEN. WOOD POSTS SHALL BE PAINTED WHITE. ALL POSTS SHALL BE NEATLY CONSTRUCTED, AND SHALL BE REPLUMBED, CLEANED, OR REPAIRED AS NEEDED FOR THE DURATION OF THE JOB. THERE SHALL NOT BE MORE THAN 2 POSTS IN A 7' PATH FOR WOOD OR CHANNEL POSTS. ANY CHANNEL POST SPLICE SHALL BE IN ACCORDANCE WITH STANDARD DRAWING TC-3.
- POST MOUNTED SIGNS IN RURAL AREAS SHALL BE CONSTRUCTED WITH THE NEAR EDGE OF THE SIGN FROM 6 TO 12 FEET FROM THE PAVEMENT EDGE. SIGNS IN URBAN AREAS AND BARRICADE MOUNTED SIGNS SHALL BE MOUNTED A MINIMUM OF 2 FEET FROM THE PAVEMENT EDGE.
- ALL POST AND BARRICADE MOUNTED SIGNS MOUNTED IN URBAN AREAS SHALL BE MOUNTED A MINIMUM DISTANCE OF 7' FROM THE BOTTOM OF THE SIGN TO THE ROADWAY SURFACE. ALL POST AND BARRICADE MOUNTED SIGNS MOUNTED IN RURAL AREAS SHALL BE MOUNTED A MINIMUM DISTANCE OF 7' FROM THE BOTTOM OF THE SIGN TO THE ROADWAY SURFACE, EXCEPT A MINIMUM OF 6' SHALL BE USED WHEN MOUNTING AN ADVISORY SIGN BELOW A WARNING SIGN. TEMPORARY SIGNS MAY BE MOUNTED ON PORTABLE SUPPORTS FOR INTERMEDIATE TERM STATIONARY WORK CONDITIONS. THE SIGNS MINIMUM MOUNTING HEIGHT SHALL BE 5'. RETROREFLECTIVE DEVICES SHALL BE USED. TEMPORARY SIGNS MAY BE MOUNTED ON PORTABLE SUPPORTS FOR SHORT-TERM, SHORT DURATION, AND MOBILE CONDITIONS. THEY SHALL BE NO LESS THAN ONE (1) FOOT ABOVE THE TRAVELED WAY. LONG-TERM STATIONARY SIGNS SHALL BE DIRECT BURIED IN SOIL, UNLESS CONDITIONS NECESSITATE THE USE OF PORTABLE SIGNS, OR AS APPROVED BY THE ENGINEER. CONCRETE PADS, CONCRETE OR ROCK BALLAST, OR OTHER SOLID MATERIALS SHALL NOT BE UTILIZED WITH PORTABLE SIGN SUPPORTS.

- FLAGGERS SHALL USE REFLECTORIZED STOP-SLOW PADDLES. FLAGS MAY BE USED ONLY FOR EMERGENCY SITUATIONS.
- MOST OF THE SIGNS SHOWN ARE ORIENTED TO THE RIGHT. HOWEVER, THIS DOES NOT PRECLUDE THE USE OF MIRROR IMAGES OF THESE SIGNS WHERE THE REVERSE ORIENTATION MIGHT BETTER CONVEY TO MOTORISTS THE PROPER DIRECTION OF MOVEMENT.
- R55-1 SIGNS SHALL BE PLACED AT LEAST 1500' BUT NOT MORE THAN 1 MILE IN ADVANCE OF THE WORK ZONE. IF A SPEED LIMIT REDUCTION IS IN EFFECT, THE SIGN SHALL BE PLACED A MINIMUM OF 500' IN ADVANCE OF THE "REDUCED SPEED AHEAD" SIGN.

* NOTE: SUPPORTS FOR SIGNS, BARRICADES, AND VERTICAL PANELS THAT ARE DIFFERENT FROM THE REQUIREMENTS SHOWN IN NOTES 4 & 5, BUT MEET THE REQUIREMENTS OF NCHRP-350 OR MANUAL FOR ASSESSING SAFETY HARDWARE (MASH), WILL BE ACCEPTED. COMPLIANCE WITH THE REQUIREMENTS OF NCHRP-350 OR MANUAL FOR ASSESSING SAFETY HARDWARE (MASH) IS REQUIRED FOR ALL PROJECTS.

12-15-81	REVISED W24-1	
11-17-10	DELETED W8-9a & ADDED W8-9	
10-15-09	ADDED REFERENCE TO MASH & ADDED SIGN W24-1	
4-17-08	REVISED SIGN DESIGNATIONS	
11-18-04	REVISED NOTES	
10-9-03	REVISED NOTE 1	
8-16-01	REVISED NOTE 7	
9-28-00	REVISED NOTE	
11-18-98	ADDED NOTE	
6-26-97	REVISED NOTE 5	
4-03-97	REVISED NOTE 5	
10-18-96	ADDED CONTROLLED ACCESS HWY. SIGN & TO NOTE 7	
10-12-95	ADDED R55-1	
6-8-95	REVISED TO CORRECT SIGN ILLUSTRATIONS	6-8-95
2-2-95	REVISED PER PART VI, MUTCD SEPT. 3, 1993	
8-15-91	DRAWN AND PLACED IN USE	
DATE	REVISION	FILMED

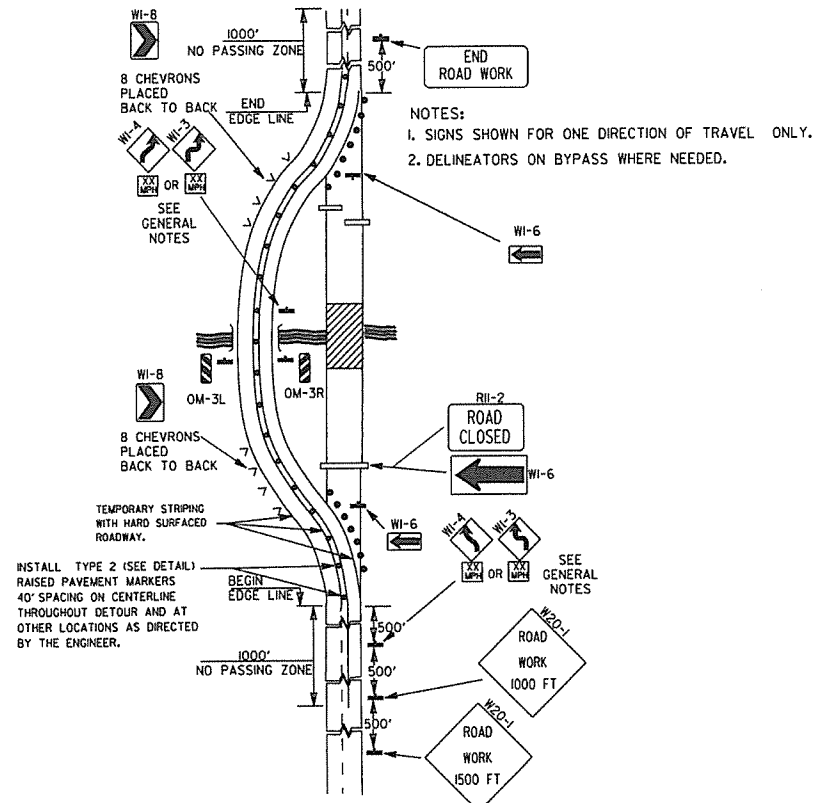

(A) TYPICAL APPLICATION OF TRAFFIC CONTROL DEVICES ON A 2-LANE HIGHWAY WHERE THE ENTIRE ROADWAY IS CLOSED AND A BYPASS DETOUR IS PROVIDED.

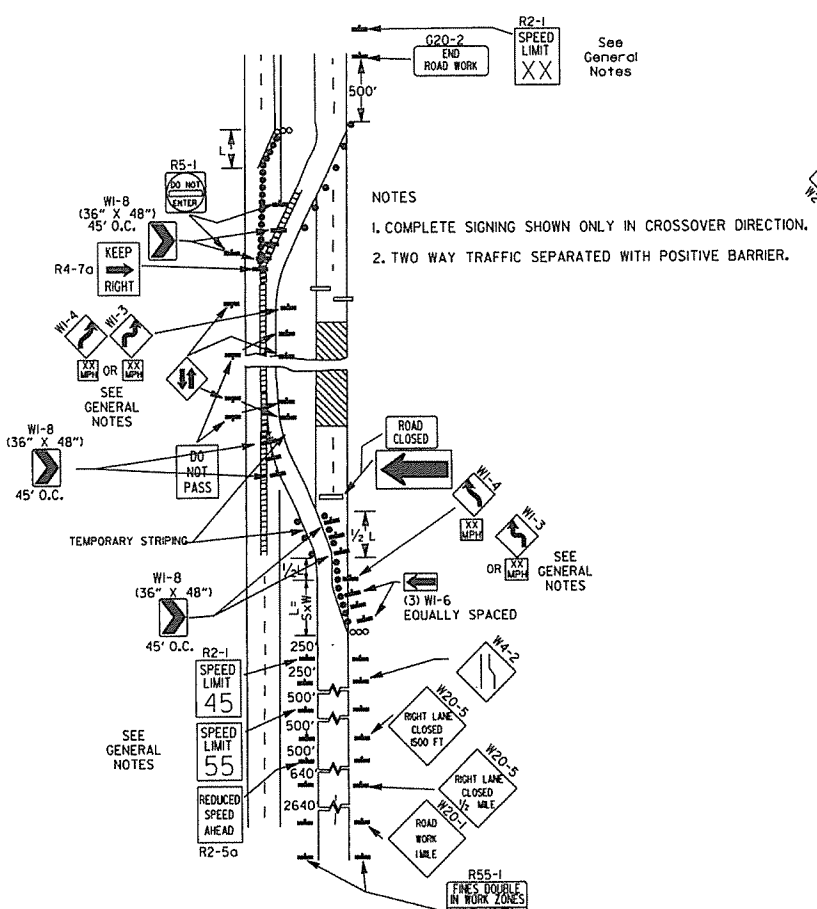

(B) TYPICAL APPLICATION - 4-LANE DIVIDED ROADWAY WHERE ONE ROADWAY IS CLOSED.

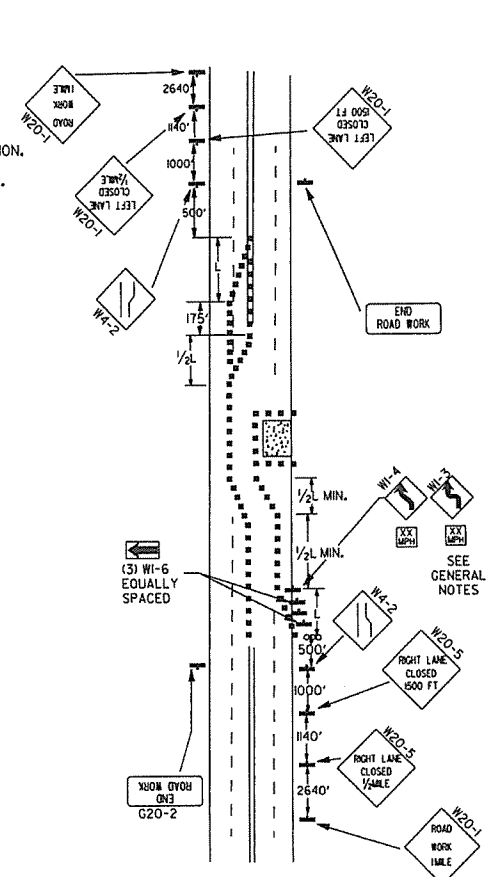

(C) TYPICAL APPLICATION - 4-LANE UNDIVIDED ROADWAY WHERE HALF OF THE ROADWAY IS CLOSED.

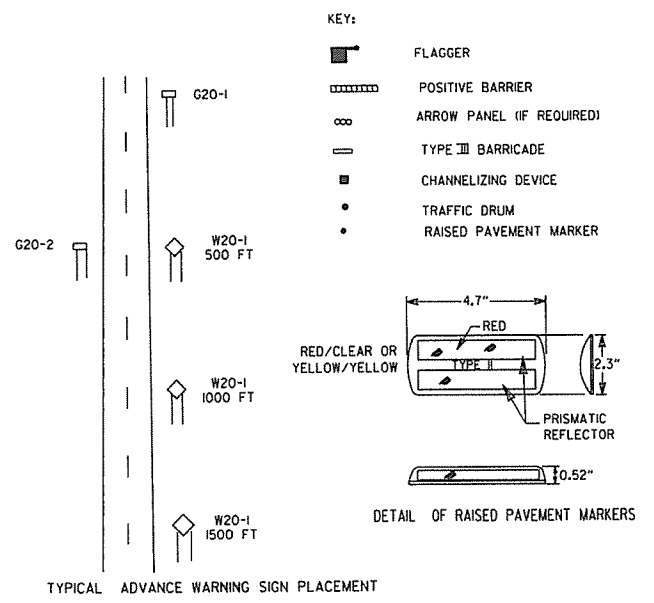

TAPER FORMULAE:
L=SWX FOR SPEEDS OF 45MPH OR MORE.
L= WS² / 60 FOR SPEEDS OF 40MPH OR LESS.
WHERE:
L= MINIMUM LENGTH OF TAPER.
S= NUMERICAL VALUE OF POSTED SPEED LIMIT PRIOR TO WORK OR 85TH PERCENTILE SPEED.
W= WIDTH OF OFFSET.

- GENERAL NOTES:
- ADVISORY SPEED POSTED ON WI-3 OR WI-4 CURVE WARNING SIGNS TO BE DETERMINED AT SITE. USE WI-4 WHEN SPEED IS GREATER THAN 30MPH AND WI-3 WHEN 30MPH OR LESS.
 - WHEN THE EXISTING SPEED LIMIT IS 55MPH AND THE PLANS REQUIRE A SPEED LIMIT OF 45MPH, THE R2-1(55) SHALL BE OMITTED AND THE R2-5A SHALL BE INSTALLED AT THAT LOCATION. ADDITIONAL R2-1(45)MPH SPEED LIMIT SIGNS SHALL BE INSTALLED AT A MAXIMUM OF 1MILE INTERVALS. AT THE END OF THE WORK AREA A R2-1(XX) SHALL BE INSTALLED TO MATCH ORIGINAL SPEED LIMIT.
 - WHEN THE EXISTING SPEED LIMIT IS 65MPH AND THE PLANS REQUIRE A SPEED LIMIT OF 55MPH, THE R2-1(65) SHALL BE OMITTED. ADDITIONAL R2-1(55)MPH SPEED LIMIT SIGNS SHALL BE INSTALLED AT A MAXIMUM OF 1MILE INTERVALS. AT THE END OF THE WORK AREA A R2-1(XX) SHALL BE INSTALLED TO MATCH ORIGINAL SPEED LIMIT.
 - THE MAXIMUM SPACING BETWEEN CHANNELIZING DEVICES IN A TAPER SHOULD BE APPROXIMATELY EQUAL IN FEET TO THE SPEED LIMIT. BEYOND THE TAPER, MAXIMUM SPACING SHALL BE TWO TIMES THE SPEED LIMIT, OR AS DIRECTED BY THE ENGINEER.
 - WARNING LIGHTS AND/OR FLAGS MAY BE MOUNTED TO SIGNS OR CHANNELIZING DEVICES AT NIGHT AS NEEDED.
 - PAVEMENT MARKINGS NO LONGER APPLICABLE WHICH MIGHT CREATE CONFUSION IN THE MINDS OF VEHICLE OPERATORS SHALL BE REMOVED OR OBLITERATED AS SOON AS PRACTICABLE.
 - TRAILER MOUNTED DEVICES SUCH AS ARROW PANELS AND PORTABLE CHANGEABLE MESSAGE SIGNS SHALL BE DELINEATED BY AFFIXING THE CONSPICUITY MATERIAL IN A CONTINUOUS LINE ON THE FACE OF THE TRAILER, WHEN PLACED ON OR ADJACENT TO THE SHOULDER AND NOT BEHIND A POSITIVE BARRIER, THESE DEVICES SHALL BE DELINEATED BY PLACING FIVE (5) TRAFFIC DRUMS, EQUALLY SPACED ALONG THE TRAFFIC SIDE OF THE DEVICE.

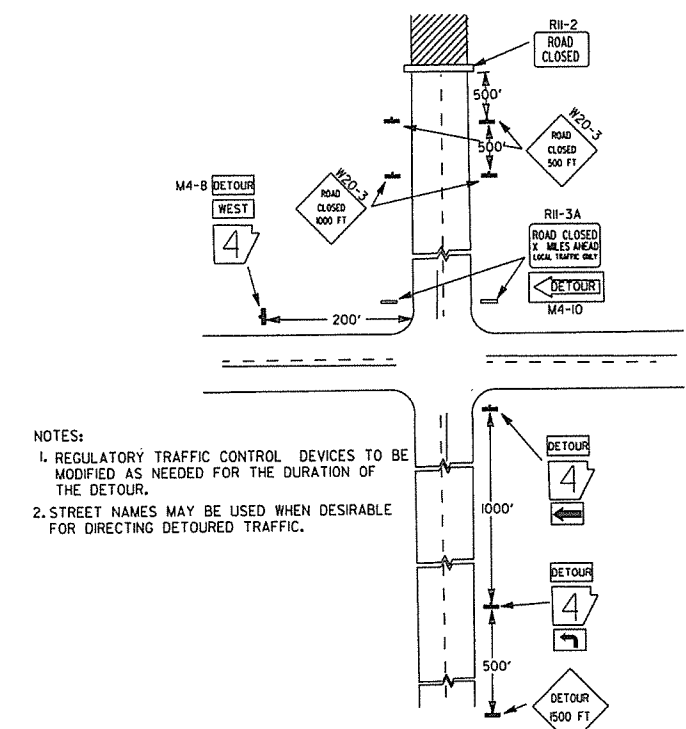

(D) TYPICAL APPLICATION - ROADWAY CLOSED BEYOND DETOUR POINT.

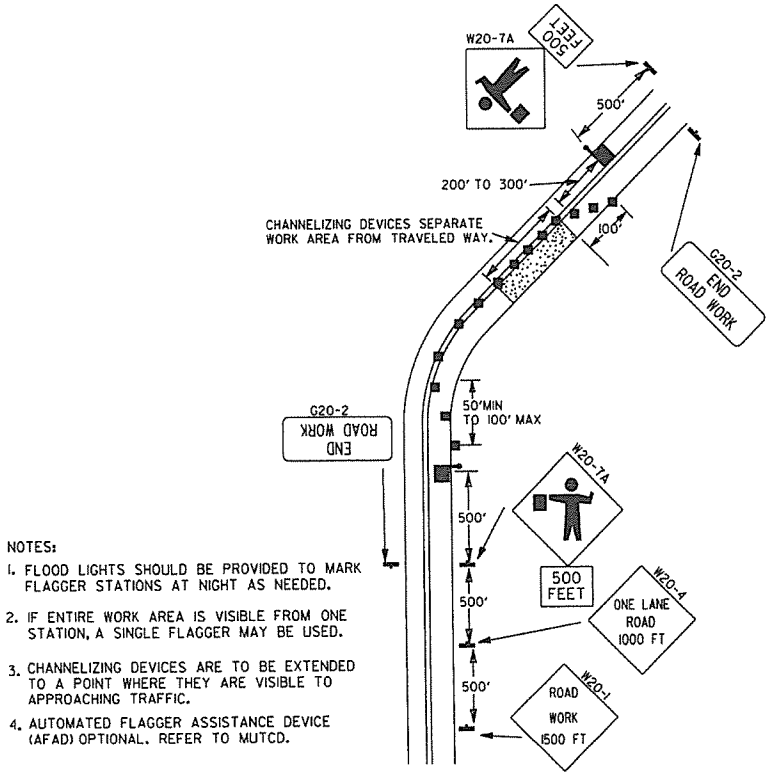

(E) TYPICAL APPLICATION OF TRAFFIC CONTROL DEVICES ON 2-LANE HIGHWAY WHERE ONE LANE IS CLOSED AND FLAGGING IS PROVIDED.

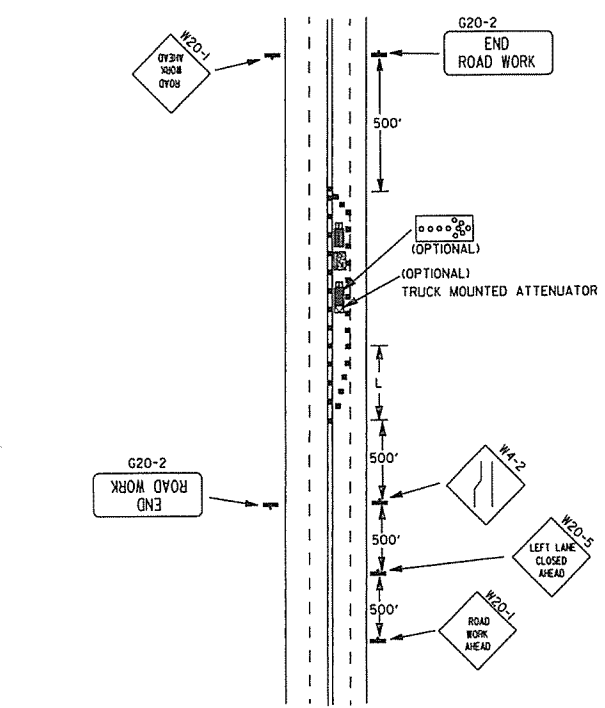

(F) TYPICAL APPLICATION - 4-LANE UNDIVIDED ROADWAY WITH INSIDE LANE CLOSED.

DATE	REVISION	FILED
9-12-13	REVISED DETAIL OF RAISED PAVEMENT MARKERS	
3-11-10	ADDED (AFAD)	
11-20-08	REVISED SIGN DESIGNATIONS	
11-18-04	ADDED GENERAL NOTE	
10-18-96	ADDED R55-1	
4-26-96	CORRECTED (a) BEHIND G20-2	
6-8-95	CORRECTED SIGN IDENT. ON W1-4A	6-8-95
2-2-95	REVISED PER PART VI, MUTCD, SEPT. 3, 1993	
8-15-91	DRAWN AND PLACED IN USE	

Channelizing devices

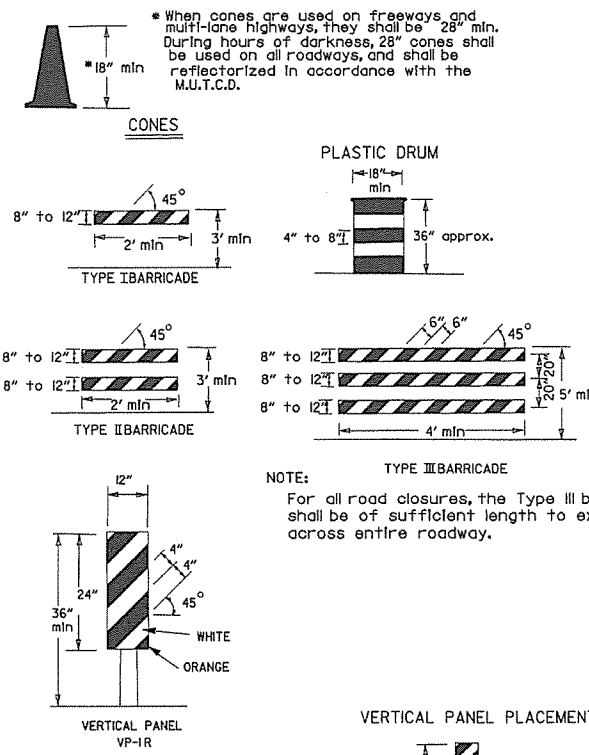

TRAFFIC CONTROL DEVICES FOR VERTICAL PAVEMENT DIFFERENTIALS

VERTICAL DIFFERENTIAL	LOCATIONS	TRAFFIC CONTROL
1" to 3"	Centerline, lane lines	W8-11
1" to 3"	Edge of shoulder	W8-9
Greater than 3"	Lane lines	Standard lane closure required
Greater than 3"	Edge of traveled lane	*RSP-I and vertical panels, drums or concrete barrier
Greater than 3"	Edge of shoulder	*Vertical panels, drums or concrete barrier

• When shown on the plans concrete barrier will be used.
 When the shoulder area is used as part of the traveled lane and there is insufficient width to place drums on the remaining shoulder width, then vertical panels shall be used.

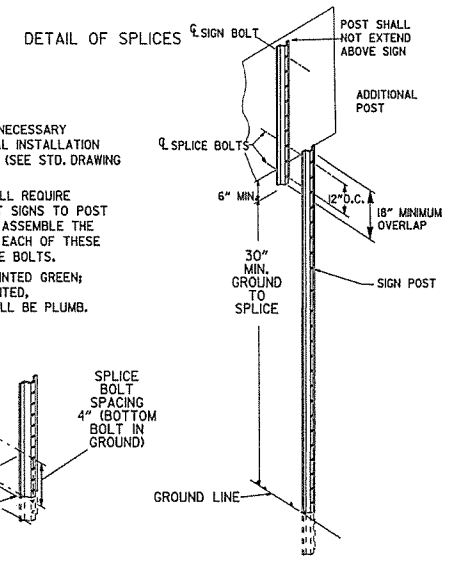
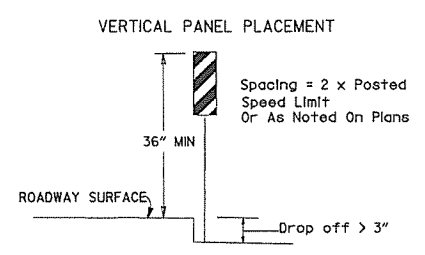
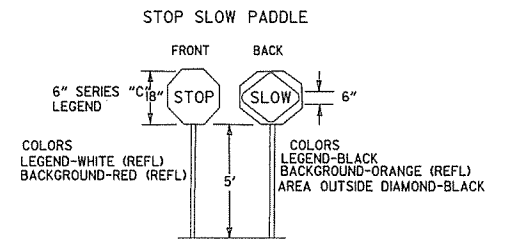
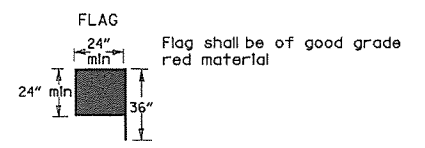

NOTES:
 USE SPLICES ONLY WHEN NECESSARY FOR INSTALLATION. TYPICAL INSTALLATION SHOULD HAVE NO SPLICES (SEE STD. DRAWING NO. SHS-2)
 NORMAL INSTALLATIONS WILL REQUIRE 1/4" DIA. BOLTS TO MOUNT SIGNS TO POST AND 5/16" DIA. BOLTS TO ASSEMBLE THE VARIOUS POST SUPPORTS. EACH OF THESE BOLTS SHALL BE CARRIAGE BOLTS.
 SIGN POSTS SHALL BE PAINTED GREEN; SIGNS SHALL NOT BE PAINTED, AND ALL SIGN POSTS SHALL BE PLUMB.

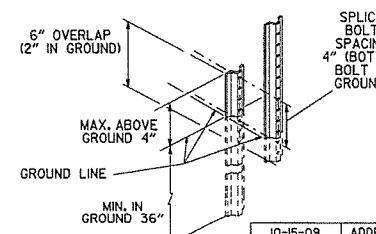

DATE	REVISION	FILED
10-15-09	ADDED REFERENCE TO MASH	
11-20-08	REVISED SIGN DESIGNATIONS	
11-18-04	ADDED NOTE	
10-1-98	ADDED NOTE	
4-03-97	ADDED (SP) TO W6-1 & REVISED TRAFFIC CONTROL DEVICES NOTE	
10-18-96	ADDED R55-1	
10-12-95	MOVED UPPER SPLICE	
6-8-95	REVISED SPLICE DETAIL, TEXT	6-8-95
2-2-95	REVISED PER PART VI, MUTCD, SEPT. 3, 1993	
8-15-91	DRAWN AND PLACED IN USE	

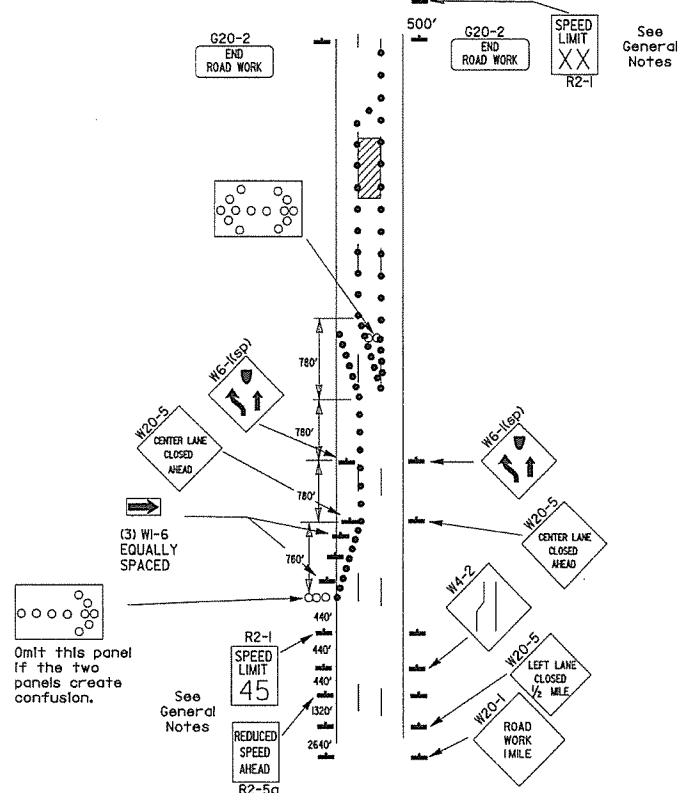
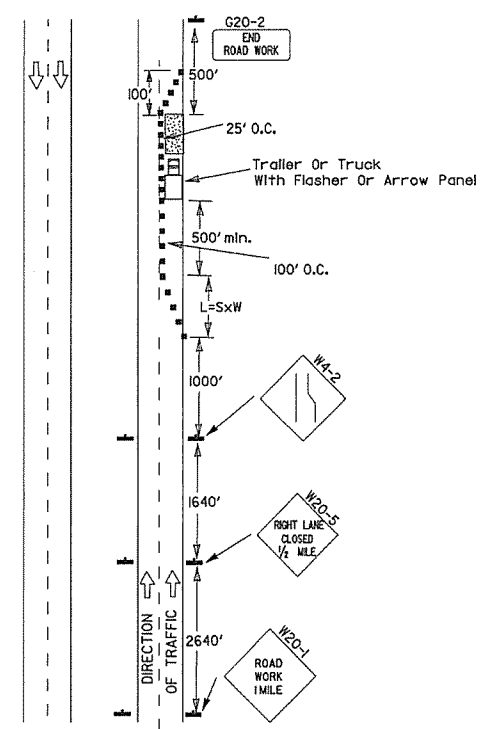

(B) Typical application - 3-lane oneway roadway where center lane is closed.

- KEY:**
- Arrow Panel (if Required)
 - Channelizing Device
 - Traffic drum

GENERAL NOTES:

- A speed limit reduction may be implemented ONLY when designated in the plan or when recommended by the Roadway Design Division.
- When the existing speed limit is 55mph and the plans require a speed limit of 45mph, the R2-1(55) shall be omitted and the R2-5a shall be installed at that location. Additional R2-1(45) speed limit signs shall be installed at a maximum of 1 mile intervals. At the end of the work area a R2-1(XX) shall be installed to match original speed limit.
- When the existing speed limit is 65mph and the plans require a speed limit of 55mph, the R2-1(65) shall be omitted. Additional R2-1(55) speed limit signs shall be installed at a maximum of 1 mile intervals. At the end of the work area a R2-1(XX) shall be installed to match original speed limit.
- The maximum spacing between channelizing devices in a taper should be approximately equal in feet to the speed limit. Beyond the taper, maximum spacing shall be two times the speed limit or as directed by the Engineer.
- Warning lights and/or flags may be mounted to signs or channelizing devices at night as needed.
- Pavement markings no longer applicable which might create confusion in the minds of vehicle operators shall be removed or obliterated as soon as practicable.
- The G20-1 sign will be required on jobs of over two miles in length. When the lane closure is not at the beginning of the project, the G20-1 sign shall be erected 125' in advance of the job limit. Additional W20-1 (1 MILE) signs are not required in advance of lane closures that begin inside the project limits.
- Flaggers shall use STOP/SLOW paddles for controlling traffic through work zones. Flags may be used only for emergency situations.
- All plastic drums and cones shall meet the requirements of NCHRP-350 or Manual For Assessing Safety Hardware (MASH).
- Trailer mounted devices such as arrow panels and portable changeable message signs shall be delineated by affixing conspicuity material in a continuous line on the face of the trailer. When placed on or adjacent to the shoulder and not behind a positive barrier, these devices shall be delineated by placing five (5) traffic drums, equally spaced along the traffic side of the device.

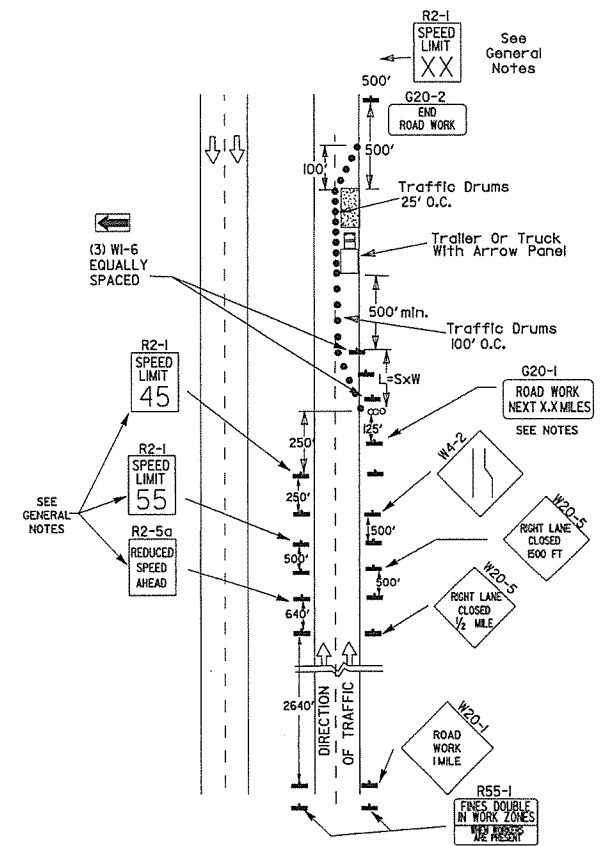

(C) Typical application - construction operations of intermediate to long term duration on a 4-lane divided roadway where half of the roadway is closed.

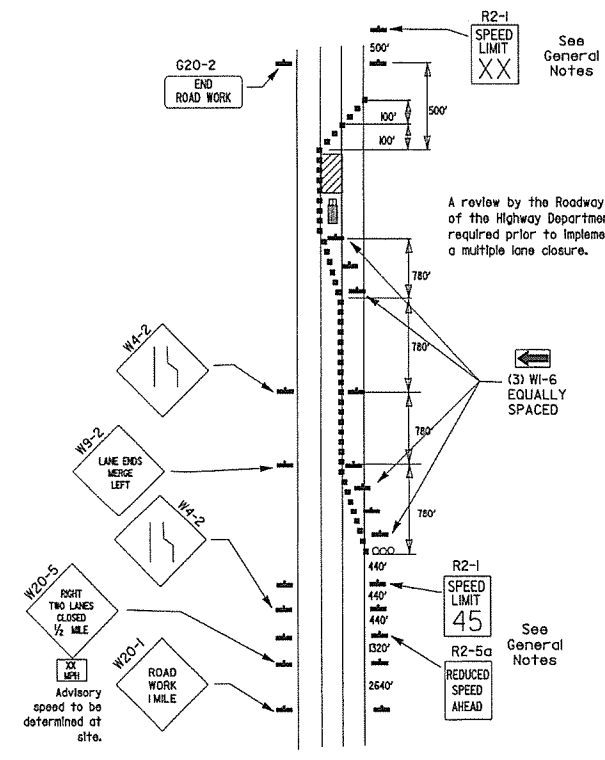

(D) Typical application - closing multiple lanes of a multilane highway.

REINFORCING BAR TABLE PER BARRIER UNIT			
MARK	LOCATION	BAR SIZE	(NO. BARS)
H-1	HORIZONTAL IN BARRIER TIED INSIDE V-1 BARS	#5	(6)
H-2	CENTERED ABOVE DRAIN SLOTS LONG. & TRANSVERSELY	#5	(6)
H-3	TIED ABOVE H-1 BARS TO SUPPORT H-2, TIED TO V-1	#4	(2)
S-1	OVER LIFT HOLES	#4	(2)
S-2	HORIZ. AROUND SLOTS BETWEEN V-1'S & DRAIN SLOTS	#4	(2)
V-1	VERTICAL IN BARRIER (3) EACH END & (2) AT EACH DRAIN SLOTS	#5	(16)

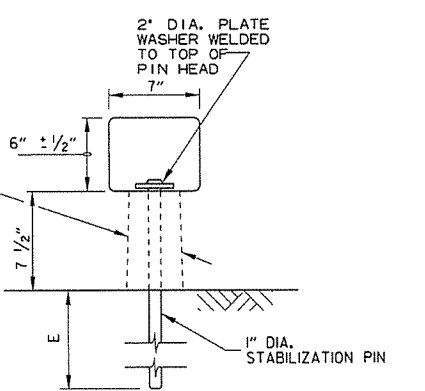
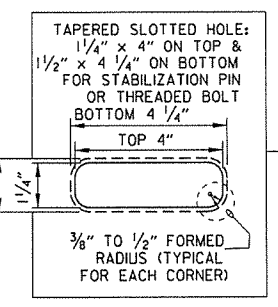
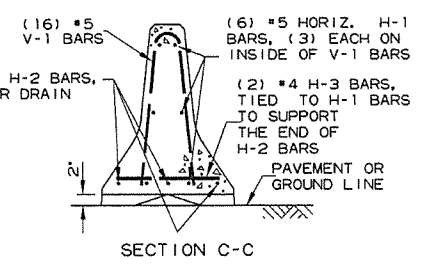
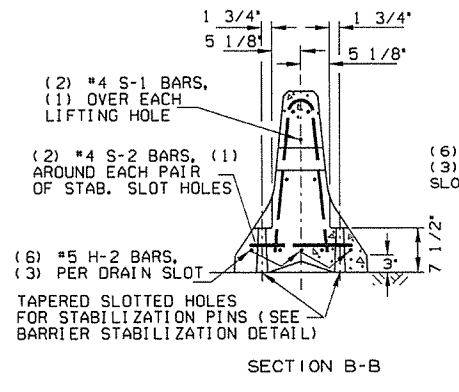
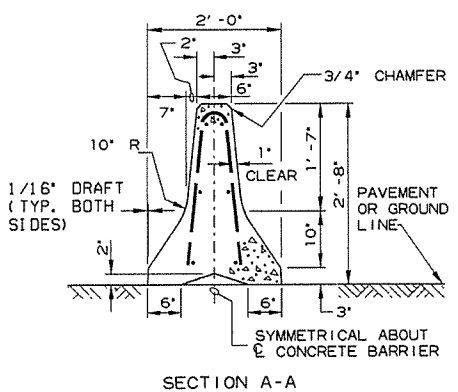
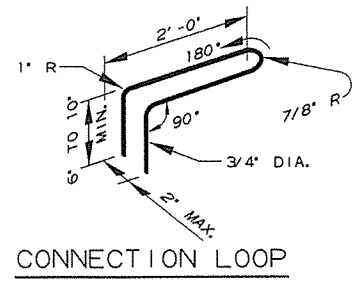
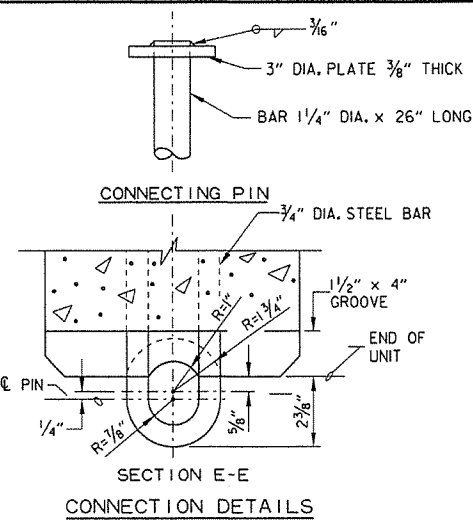

BARRIER STABILIZATION DETAIL

ROADWAY SECTION
 (E) 4" - Concrete Pavement
 8" - Asphalt Pavement
 12" - Shoulder Areas

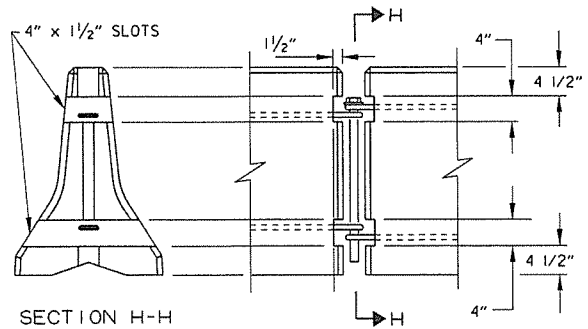

BARRIER REMOVAL SLOT DETAILS

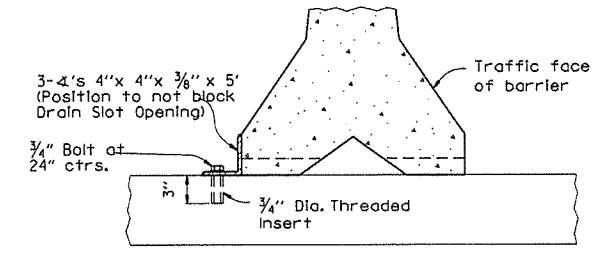

BARRIER STABILIZATION DETAIL
 BRIDGE DECKS

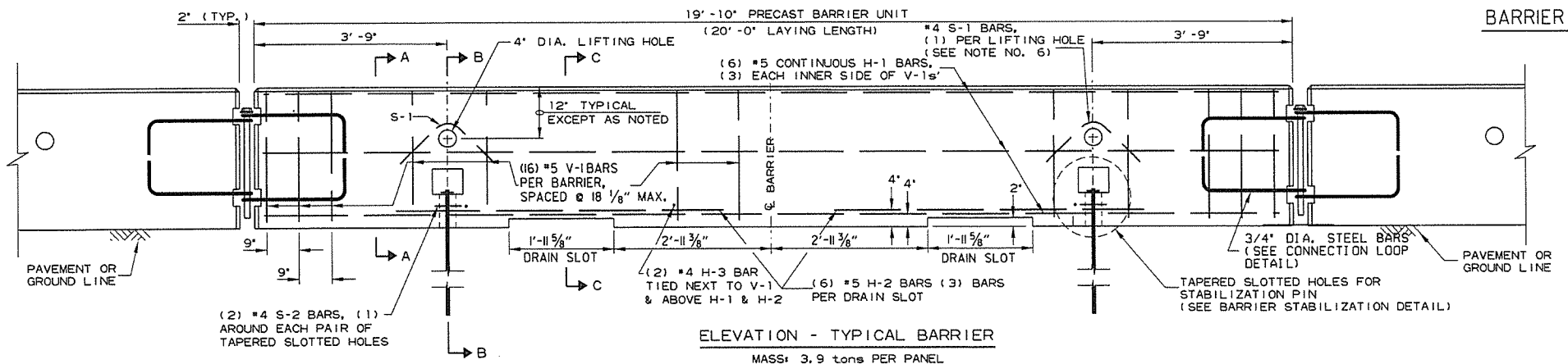
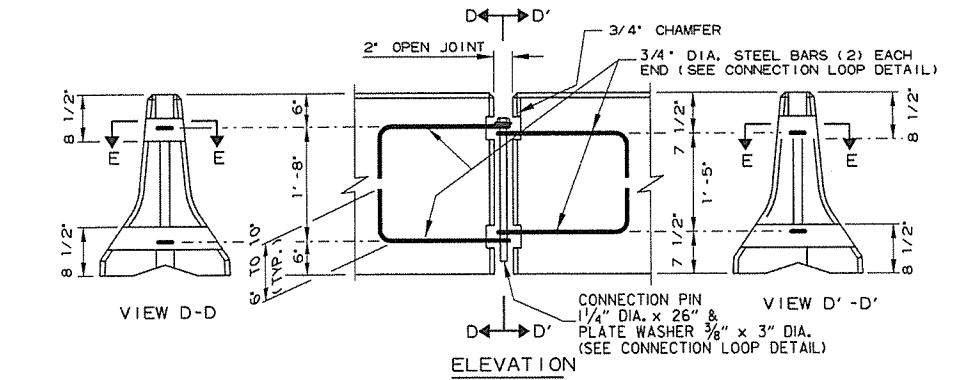

ELEVATION - TYPICAL BARRIER
 MASS: 3.9 tons PER PANEL

- General Notes**
- The contractor shall furnish the Precast Concrete Barrier Units and shall be responsible for the manufacture, shipment, storage, placement and removal. At the completion of the project, the precast units will remain the property of the contractor.
 - Materials shall meet the following minimum requirements:
 Concrete: 2500 psi compressive strength at 28 days.
 Reinforcing Steel: AASHTO M 31 or M 53, Grade 60
 Structural Steel: AASHTO-M270 Grade 36 shall be used for the Connection Pin, Connection Loops, and Stabilization Pins. A One Piece Pin with a 3" rounded top may be used in place of the detailed Connection Pin. Delineators: Delineators shall be mounted at 10' spacing on top of precast barrier.

 In applications where barrier walls within 6 feet of a traffic lane, additional delineators shall be placed on the barrier at 10' spacing approximately one (1) foot from the top of the barrier. Delineators shall be on the AHTD Qualified Products List for Construction Concrete Barrier Markers. Delineator color shall be in accordance with the Manual Uniform Traffic Control Devices. Payment for delineators shall be considered included in the price bid per Lin. Ft. for "Furnishing and Installing Precast Concrete Barrier". The contractor shall certify to the Engineer that the material and the design used in the precast barrier units meets the requirements as shown on this standard drawing.
 - Other Precast Concrete Barriers that have been crash tested and approved by the Federal Highway Administration to meet the requirements of NCHRP-350 test level 3 or Manual For Assessing Safety Hardware (MASH) will be accepted in lieu of the barrier shown. Drain slots shall be provided as needed or as directed by the Engineer. The Contractor shall furnish a certification of NCHRP Report 350 or Manual For Assessing Safety Hardware (MASH) compliance for any other types of precast barrier to be used. The certification shall state that the precast concrete barrier meets the requirements of NCHRP Report 350 or Manual For Assessing Safety Hardware (MASH) and include a copy of the Federal Highway Administration's (FHWA) approval letter with all attachments. Precast concrete barrier units shall be fabricated and installed in accordance with crash testing and documentation provided in the FHWA approval letter. Mixing of shapes will not be allowed in a continuous line of units.
 - Dowel holes in pavement or bridge slabs that are to remain in place shall be filled. Holes in concrete pavement and bridge slabs shall be filled with an approved non-shrink epoxy grout. Holes in asphalt pavement shall be filled with an approved asphalt joint filler. Payment for drilling and filling holes to be included in the price for various barrier items.
 - Attach Units To Roadway Surface with Stabilization Pins and to Deck Slabs using bolts when required.
 - A 4" White PVC Sleeve may be used to form the Lifting Hole and if used the Sleeve is to be left in place.

DATE	REVISION	FILMED
2-27-14	REVISED BARRIER STABILIZATION DETAIL	
10-15-09	ADDED REFERENCE TO MASH	
8-5-09	REV. NOTE 3 CONCERNING DRAIN SLOTS	
11-29-07	REVISED NOTE 3	
5-25-06	DELETED GENERAL NOTE 7	
11-18-04	REVISED BARRIER STABILIZATION DETAIL BRIDGE DECKS	
4-10-03	REVISED GENERAL NOTE 2	
8-22-02	ISSUED NEW DRAWING	

ARKANSAS STATE HIGHWAY COMMISSION
 STANDARD TRAFFIC CONTROLS
 FOR HIGHWAY CONSTRUCTION -
 TEMPORARY PRECAST BARRIER
 STANDARD DRAWING TC-4

(A) 4 feet or greater preferred. If less than 4 feet, Precast Units shall be connected to slab (SEE BARRIER STABILIZATION DETAIL-BRIDGE DECKS STD. DRWG. TC-4)

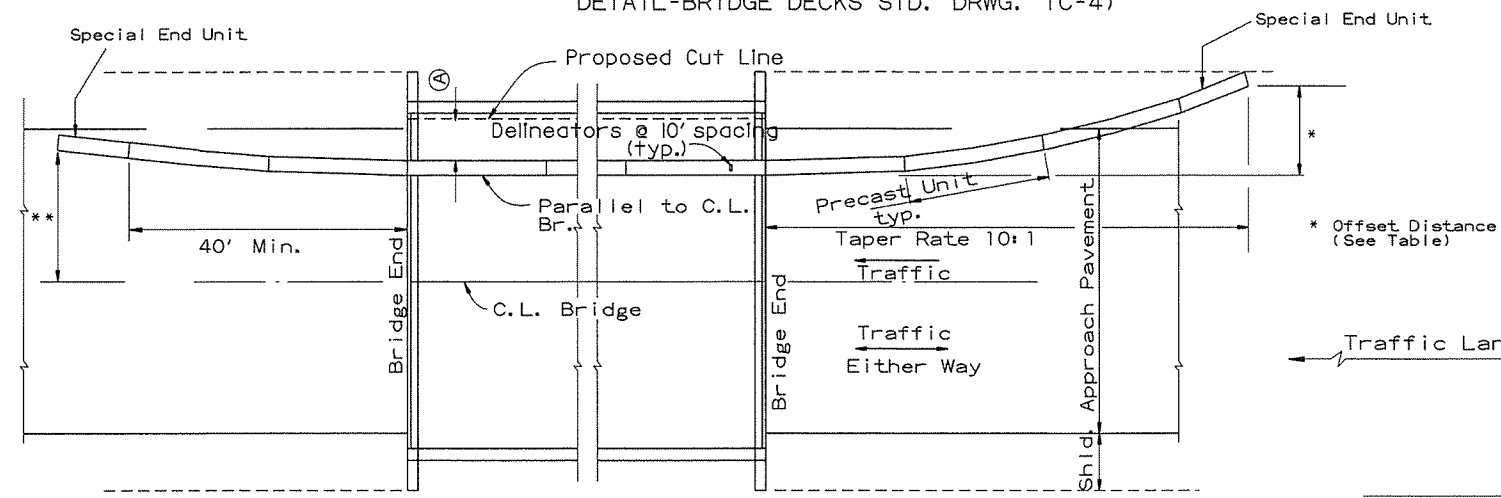

BARRIER PLACEMENT ALONG BRIDGE WITH OFFSET

No Scale

** Offset Distance for Two Way Traffic Only

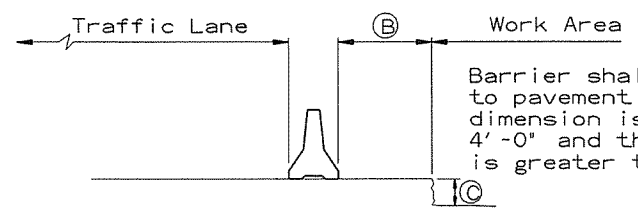

SECTION J-J

No Scale

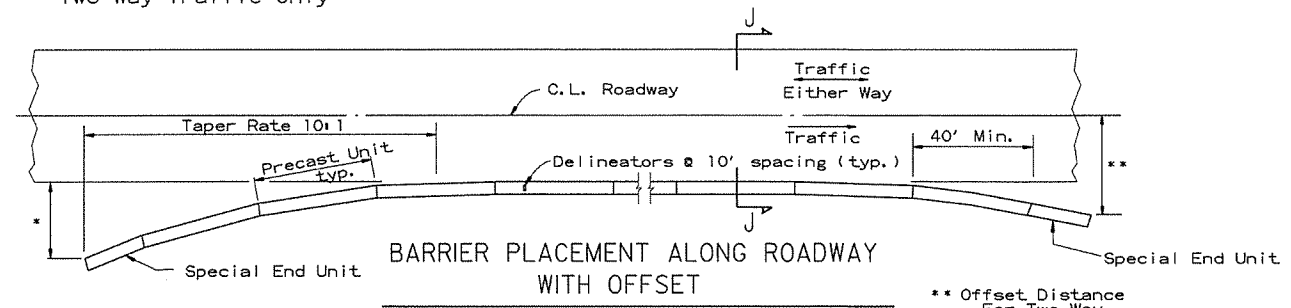

BARRIER PLACEMENT ALONG ROADWAY WITH OFFSET

No Scale

* Offset Distance (See Table)

** Offset Distance For Two Way Traffic Only

Offset Distance Table

Speed (MPH)	Offset Distance (FT.)
≤ 45	12
> 45	18

If offset distance is not attainable, then see 'Barrier Placement With Attenuator' Detail shown below.

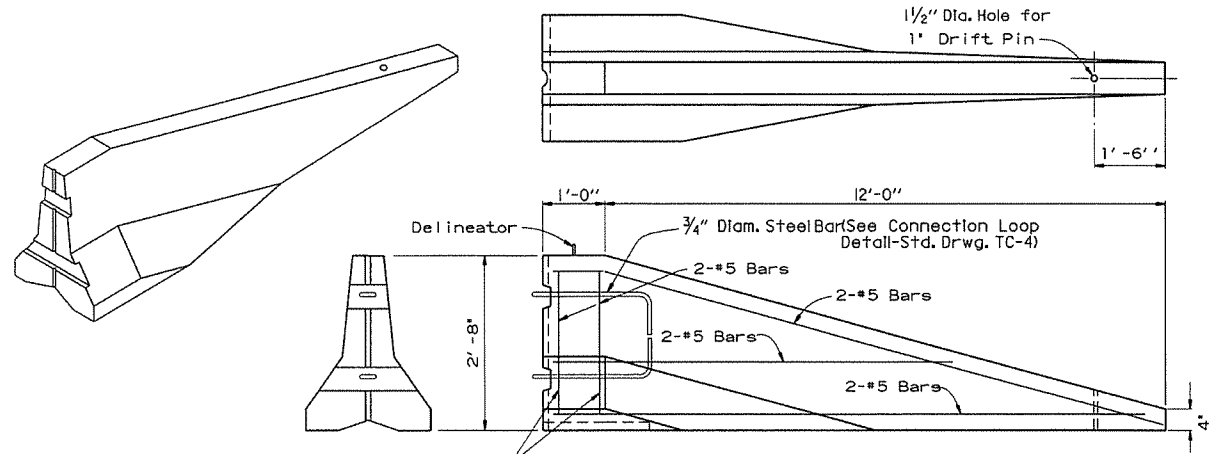

SPECIAL END UNIT

No Scale

General Notes

When shown on the Plans, the ends of the Temporary Precast Concrete Barrier shall be protected with an NCHRP-350 or Manual For Assessing Safety Hardware (MASH) approved Crash Cushion. Payment for Crash Cushions shall be made under the item of "Temporary Impact Attenuation Barrier."

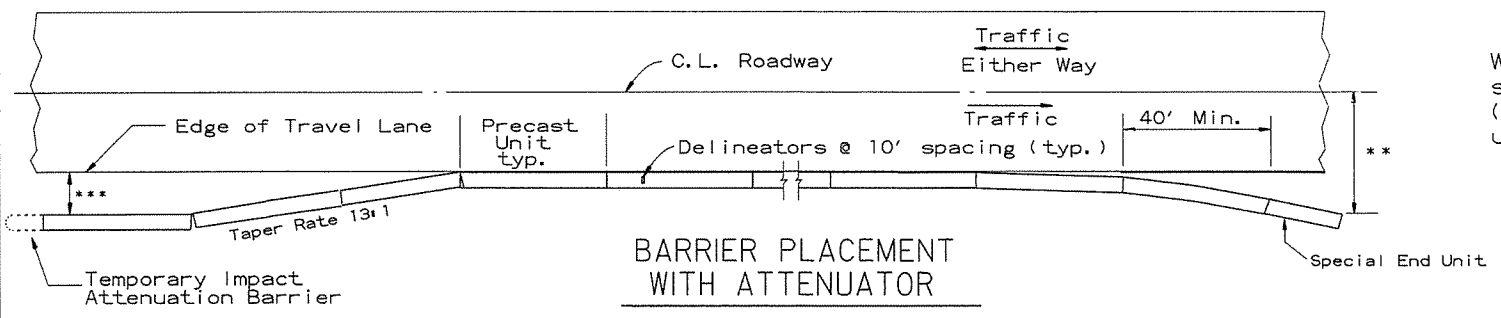

BARRIER PLACEMENT WITH ATTENUATOR

No Scale

** Offset Distance For Two Way Traffic Only

***Min. 3'-0" From Edge of Travel Lane to Nearest Edge of Attenuator

			ARKANSAS STATE HIGHWAY COMMISSION
			STANDARD TRAFFIC CONTROLS FOR HIGHWAY CONSTRUCTION - TEMPORARY PRECAST BARRIER
			STANDARD DRAWING TC-5
10-15-09	ADDED REFERENCE TO MASH		
5-25-06	REVISED BARRIER PLACEMENT		
8-22-02	ISSUED NEW DRAWING		
DATE	REVISION	FILMED	

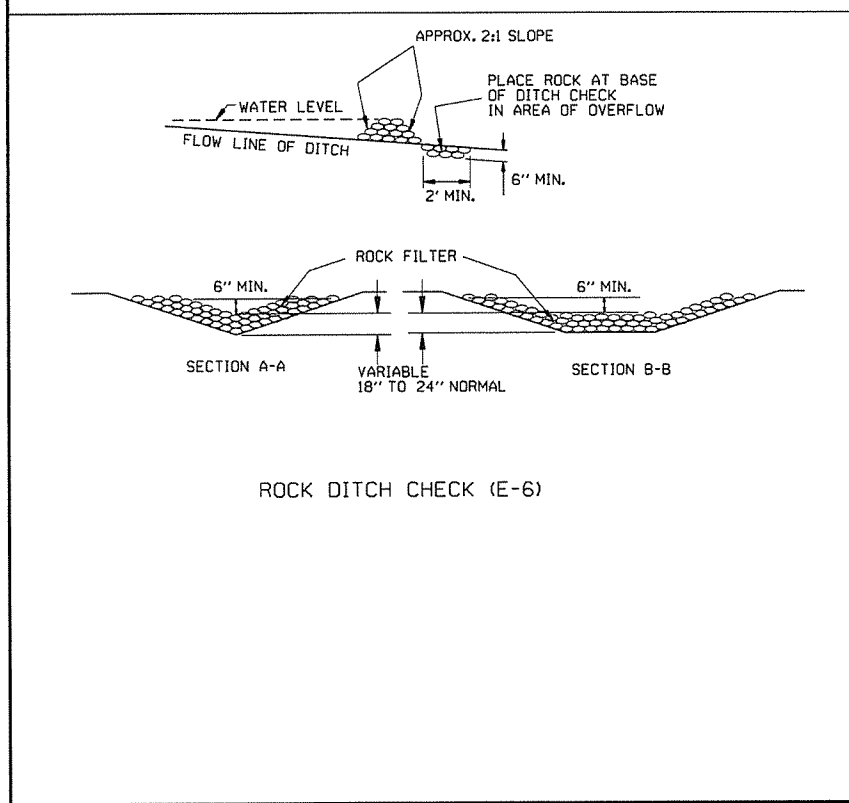
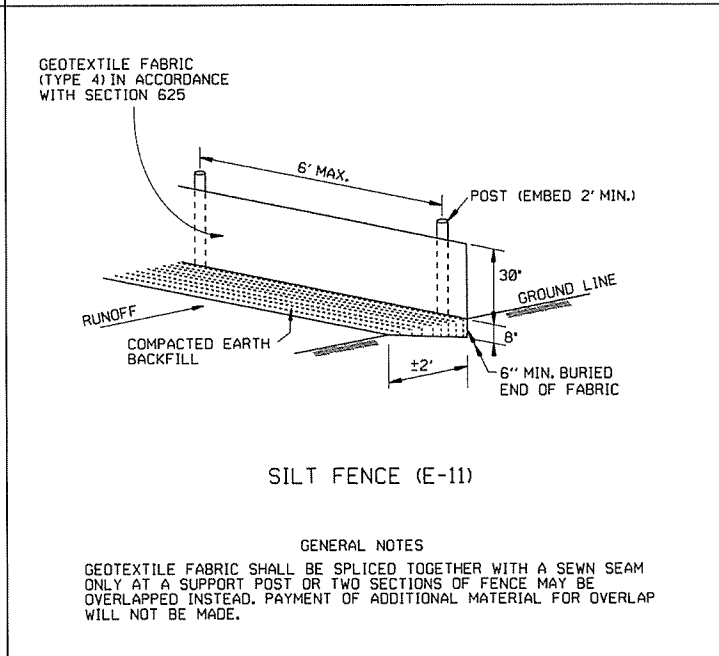
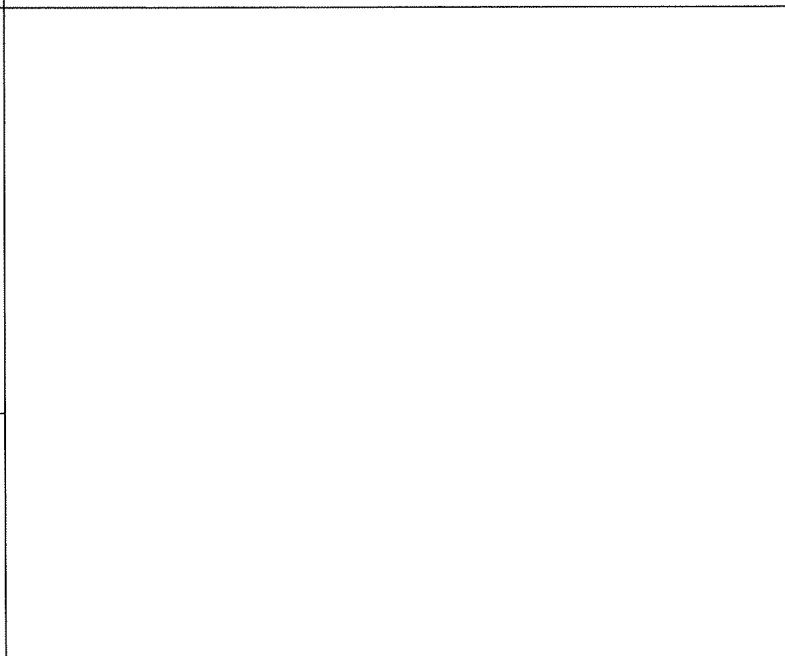
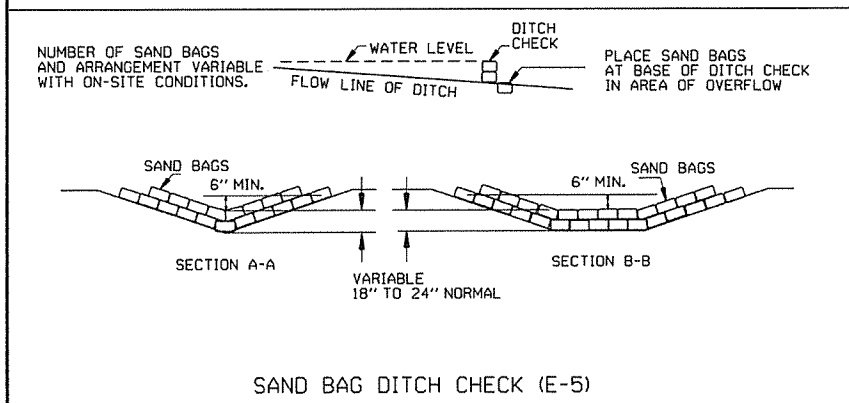
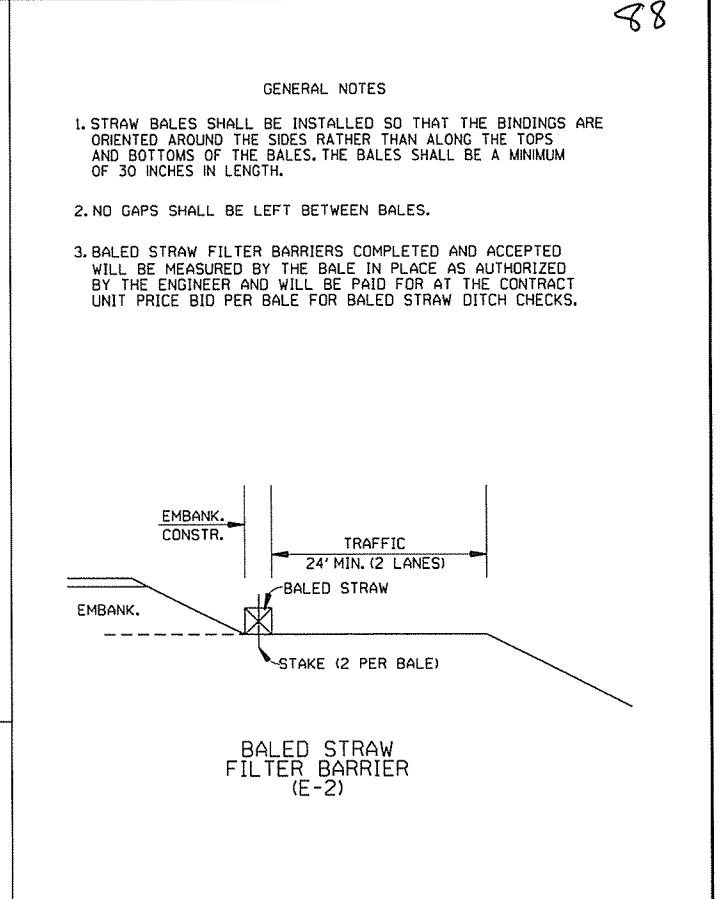
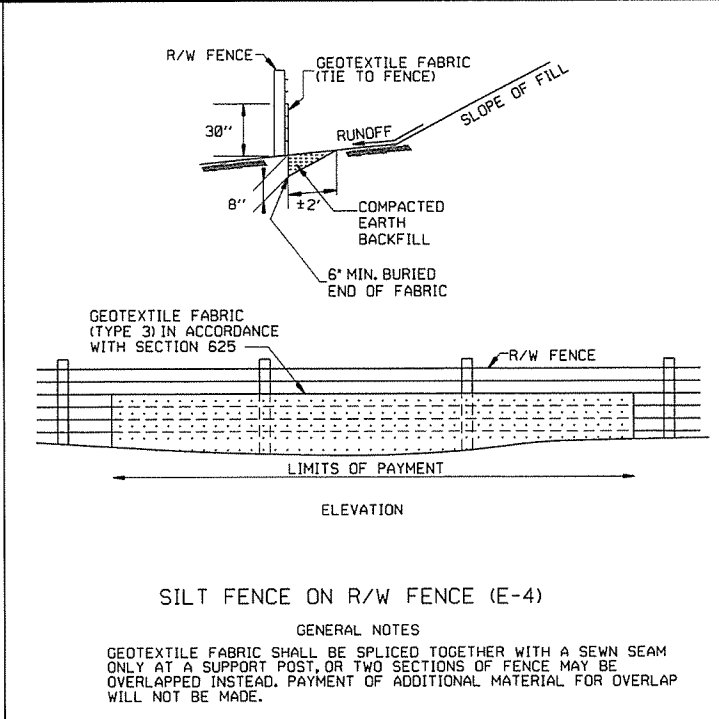
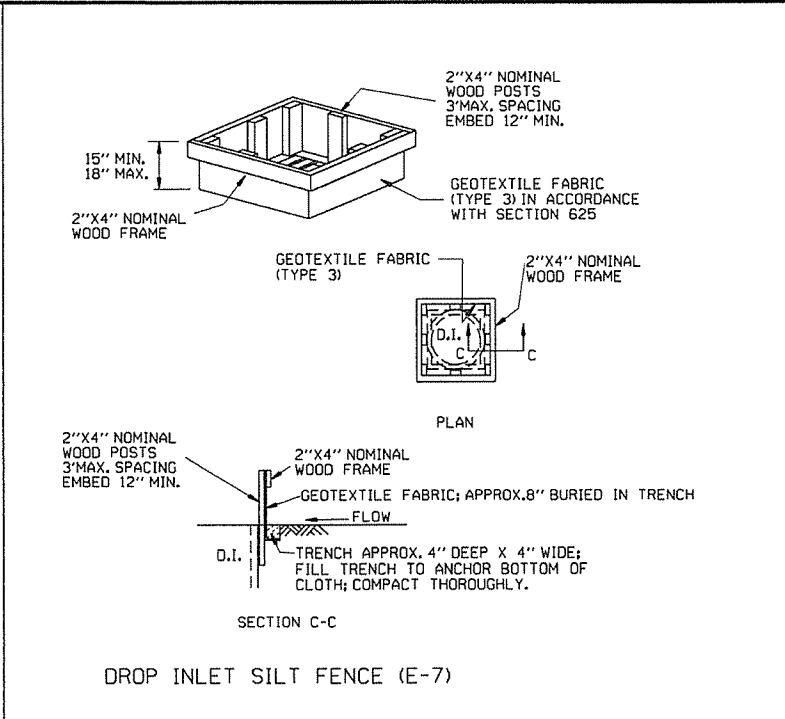
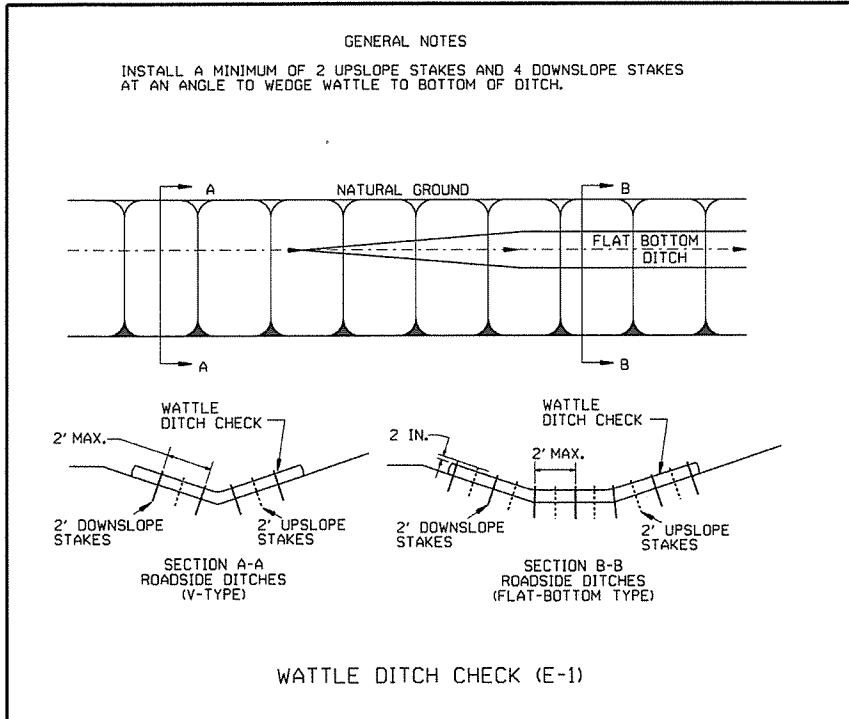

12-15-11	DELETED BALED STRAW DITCH CHECK & ADDED WATTLE DITCH CHECK		ARKANSAS STATE HIGHWAY COMMISSION
11-18-98	ADDED NOTES		
7-02-98	ADDED BALED STRAW FILTER BARRIER (E-2)		
7-20-95	REVISED SILT FENCE E-4 AND E-11	7-20-95	
7-15-94	REV. E-4 & E-11 MIN. 13" BURIED END OF FABRIC		
6-2-94	REVISED E-1, 4, 7 & 11; DELETED E-2 & 3	6-2-94	
4-1-93	REDRAWN		
10-1-92	REDRAWN		
8-2-76	ISSUED R.D.M.	298-7-28-76	
DATE	REVISION	FILMED	

TEMPORARY EROSION CONTROL DEVICES

STANDARD DRAWING TEC-1